

Eng

English Language



Società Industriale Costruzione Macchine Agricole

Instruction Manual
TILLERS

ATTENTION
Read carefully this manual
before using the equipment

ZL-L MODEL

c.da Cerreto - 66010 Miglianico (CH)
Telephone +39 (0)871 95841 Fax +39 (0)871 950295 - Telex 600865 SICMA I
web: www.sicma.it - e-mail: sicma@sicma.it

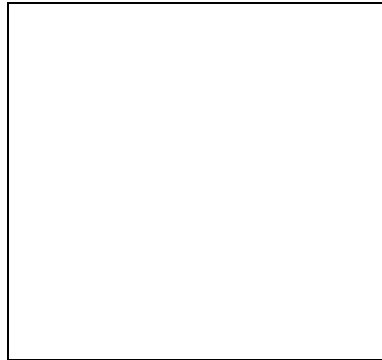

© SICMA s.p.a.

All rights reserved
Printed in Italy

Industrial Manufacture Company of Agricultural Machines

No part of this manual shall be reproduced, copied or disseminated by any means without SICMA joint-stock company prior authorization in writing.

SICMA joint-stock company reserves the right to make any necessary changes without giving prior notice in order to optimize the quality and safety of its products and without committing itself to update this manual every time a change takes place.

This booklet provides an accurate description of the operating instructions and maintenance activities to be carried out on the tiller you bought. We congratulate you on your choice and remind you that reading and following scrupulously all prescriptions here contained will assure the regular working of your machine and especially a high degree of safety.

The manufacturer therefore declines all responsibility as for the onset of problems caused by a lack of compliance with the instructions and/or negligence of the operator.

This manual is divided into chapters and paragraphs and its pages are progressively numbered in order to present information in a clear and concise way. Information, thus, can be found through the keywords used as chapters' title and especially consulting the index (page 4).

INDEX

General information

Symbols	Page4
Tightening table	Page5
Safety labels	Page 5
Technical data	Page 6
Main parts	Page 7
Identification plates	Page 7
Allowed/improper use	Page 7

Safety

Safety in the workplace	Page 8
Job clothing	Page 8
General safety rules	Page 8/9

Set up

Connection to the tractor	Page 10
Connection through Cardan joint	Page 11
Cover adjustment	Page 11
Working depth	Page 12/13
Speed gear	Page 12
Chain tension	Page13
Side shift regulation	Page 13
SH side shift	Page 14/15
Starting up	Page 15
Road transport	Page 15
Set aside	Page 15

Maintenance

Maintenance program	Page 16/17
Blade replacement	Page 18
Spare parts	Page 19

GENERAL INFORMATION

SYMBOLS

This booklet contains three "safety graphic symbols" to highlight as many danger levels or important information:



It draws the operator's attention to situations which can jeopardize people's safety.



It draws the attention to situations which jeopardize the machine efficiency but not people's safety.



It highlights general information which does not endanger people's safety or the efficiency of the parts.

BOLTS AND NUTS TIGHTENING TABLE





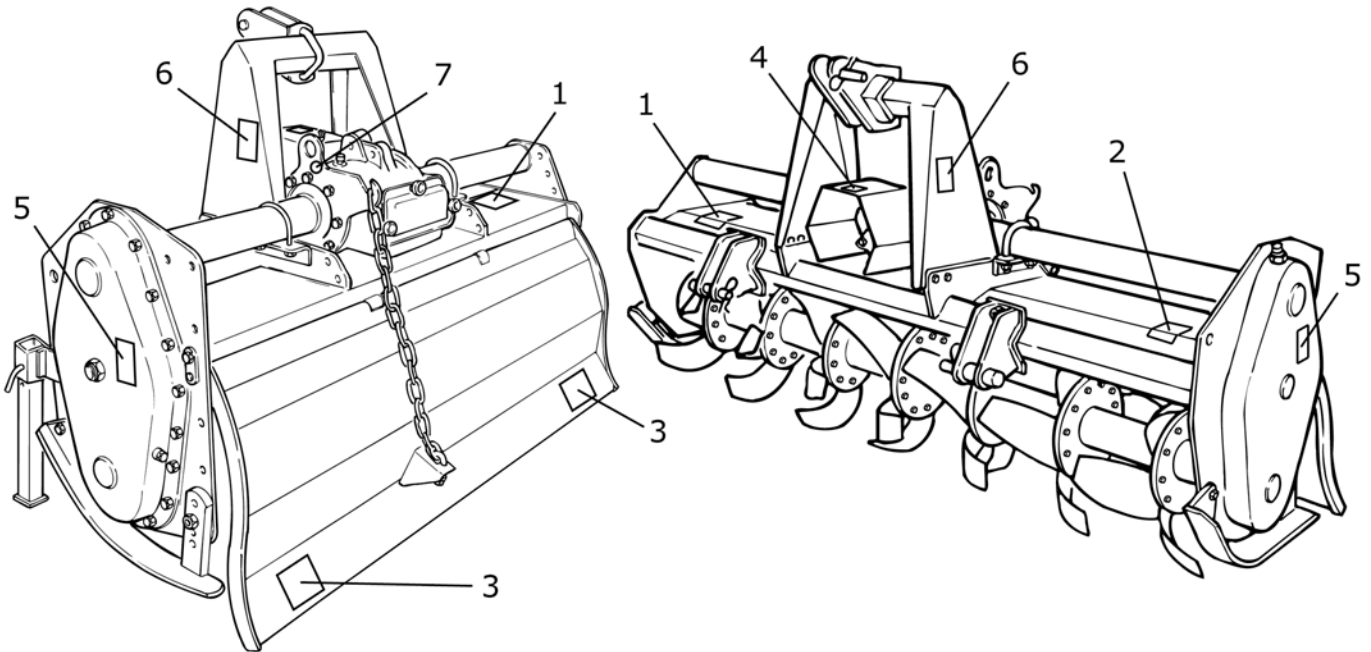

In order to tighten correctly all bolts and nuts of your tiller, we advice you to use a special dynamometrical spanner and to refer to the following table:

Screws/threaded bolts				
Bolt class				
thread	8.8		10.9	
	Nm	Lb-ft	Nm	Lb-ft
M6	11	8.5	17	12
M8	28	20	40	30
M10	55	40	80	60
M12	95	70	140	105
M14	150	110	225	165
M16	240	175	305	225
M18	330	250	475	350

SAFETY LABELS

The safety labels and the information on the machine, listed in the following table, must be necessarily carried out; failure to carry out these warnings can cause death or severe injuries. Make sure that the labels are always present and legible, should this not be the case contact your nearest SICMA dealer to replace the missing or illegible ones.



<p>1</p>  <p>Attention: read carefully all instruction and safety rules before using the machine. Stop engine and remove key before starting maintenance or repairs.</p>	<p>4</p>  <p>Use a 540 rpm power takeoff.</p>
<p>2</p>  <p>Danger of feet injuries: rotating tools, keep away from the machine.</p>	<p>7</p>  <p>Hooking point for the machine's lifting.</p>
<p>3</p>  <p>Thrown objects: keep a safety distance from the machine. Danger of hands injuries: do not open or remove safety guards while the machine is operating.</p>	<p>5</p>  <p>Danger of feet injuries: keep a safety distance from the machine.</p> <p>6</p>  <p>Danger of hands injuries: keep safety guards in position while operating.</p>

Technical data

MODEL	Working Width (cm)	Horse-power (CV)	Weight (Kg)	Working depth		Gear speed	Driveline		Blades		Blade type	
				cm	Inches		chain	gear	Per rotor	Total	“C”	“L”
SA105	105	10-10	118	15	6		x		4	20	x	
SA125	125	10-10	130	15	6		x		4	24	x	
ZLL100	100	20-35	130	18	7		x		6	30		x
ZLL120	120	20-35	152	18	7		x		6	36		x
ZLL150	150	20-35	190	18	7		x		6	42		x
CS165	165	30-50	266	18	7		x		6	48		x
CS185	185	30-50	290	18	7		x		6	54		x
ST180	180	30-60	394	20	8	x		x	6	42		x
ST205	205	30-60	400	20	8	x		x	6	48		x
SM205	205	40-70	445	20	8	x		x	6	48		x
SM230	230	40-70	450	20	8	x		x	6	54		x
SP180	180	60-90	555	25	10	x		x	6	42		x
SP205	205	60-90	605	25	10	x		x	6	48		x
SP230	230	60-90	630	25	10	x		x	6	54		x
SP255	255	60-90	655	25	10	x		x	6	60		x
SPIKE:												
RG230	230	90-160	930			x		x	43			
RG255	255	90-160	1020			x		x	48			
RG305	305	90-160	1150			x		x	58			
BLADES:												
RG255	255	90-160	90			x		x	6	60	x	
RG305	305	90-160	1180			x		x	6	72	x	

MAIN PARTS TERMINOLOGY

- A) Frame
- B) Lower three-point hitches
- C) Upper three-point hitch
- D) Cardan guard
- E) Third point mast
- F) Rotor
- G) Hoes
- H) Side skids
- I) Transmission case
- L) Cover

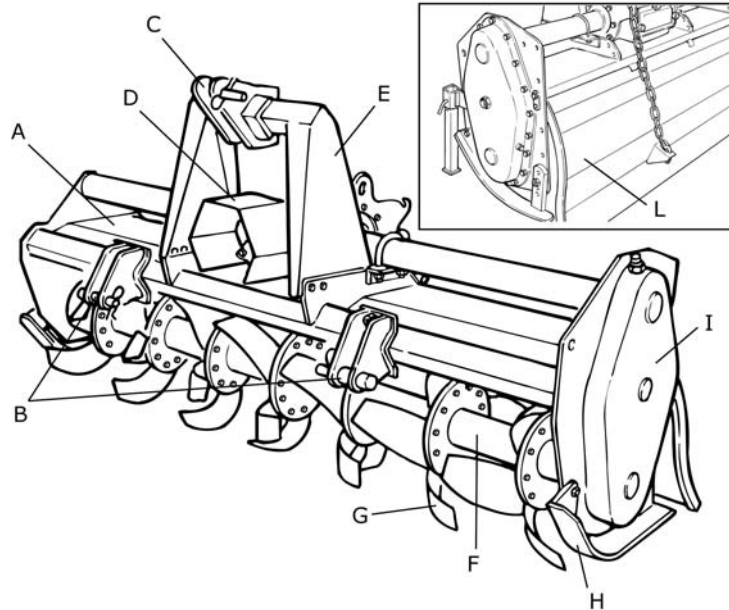

IDENTIFICATION PLATES

Identification plates are placed on every tiller and are structured as follows:

model of tiller (example)



dimension (example)



Speed gear information (example)

SICMA TYPE-TIPO RG	P.T.O. SPEED	540 rpm		1000 rpm			
		17	21	22	16	225	251
		17	21	22	230		
		22	16	225			
		21	17	251			



When asking for information or technical service, always specify the machine type and width.

ALLOWED USE

SICMA tillers, as described in this instruction and maintenance booklet, have been specifically designed to till the land.

Any other use jeopardizes the operator's safety and the machine integrity.

IMPROPER USE

When using SICMA tillers it is particularly forbidden:

- The attachment to vehicles of unsuitable power or weight.
- To assemble the machine without securing the rebound tie rods of the three-point hitch of the tractor's elevator.
- To work in excessively stony grounds
- To lift the machine when the power takeoff is engaged.
- To approach the machine when wearing inappropriate work clothing.
- To get on the machine while it is being used or transported

SAFETY

SAFETY IN THE WORKPLACE

Most of the accidents which take place while the operator is using the machine or the equipment or during their maintenance or repair are caused by a lack of compliance with the basic safety precautions.

It is necessary, therefore, to become more and more conscious of the potential risks of one's action by constantly paying attention to its effects.

If potentially dangerous situations are known, accidents can be prevented!

OPERATOR'S REQUIREMENTS

All operators using the equipment must be competent and meet necessarily the following features:

Physical: good eyesight, coordination and capability of carrying out all functions required for the machine's use.

Mental: capability of understanding and applying the established rules and safety precautions. Users must pay attention and be sensible for their own and other people's safety

Training: users must have read and studied this manual, its eventual enclosed graphs and schemes and its identification and danger plates. They must be skilled and trained on any use or maintenance activities.

WORK CLOTHING

When working and especially when executing repair or maintenance activities, it is necessary to wear the following clothing and safety accessories:

- Overalls or other comfortable clothing, not too loose to prevent the possibility that parts of them might be caught in the moving parts.
- Protective gloves for hands.
- Protective glasses or faceplate to protect eyes and face.
- Protective helmet for the head.
- Safety shoes



Wear only personal safety accessories in good condition and complying with the rules in force.

GENERAL SAFETY RULES

Always consider the features of the area where work is taking place:

- When the equipment is running, it is forbidden to stand within the field of action of the tilling cutter or of the other accessories of which it is provided with.

Prepare the work:

Before and when working do not drink alcohol, take drugs or any other substances which may alter your capability of working with machine tools.

- Be sure to have sufficient fuel, to prevent a forced stopping of the machine, maybe during a critical movement.
- Do not use the equipment under unsafe conditions. For instance, it is forbidden to execute makeshift repair activities just to start working; it is forbidden to work at night with an insufficiently illuminated working area.

When working or during the maintenance activities it is necessary to remember:

- The labels and stickers providing instructions and pointing out the dangers, must not be removed, hidden or made illegible.
- Do not remove, except in case of maintenance, the safety devices, protective covers or sumps. When it is necessary to remove them, stop engine, handle with care and reassemble them properly before restarting the engine and using the equipment.
- It is forbidden to lubricate, clean and adjust the moving parts while they are running.
- During maintenance or adjustment activities on the equipment it is forbidden to use hands for executing operations for which there are specific tools.
- Do not use tools in bad condition or inappropriately, for instance pliers rather than monkey spanners, etc.
- Before executing interventions on hydraulic lines under pressure, disconnect their components and make sure that the line is no longer under pressure and that it does not contain any hot fluid.
- Check out all pipe fittings and make sure that they are well connected before raising steam to the hydraulic lines.
- When maintenance or repairs are completed check out that no tools, wiping rags or other materials are left inside spaces or guides with moving parts.
- While using the equipment it is forbidden to make more than one person give directions and make signals. The eventual directions and signals relating to the load handling must be given by a person only.
- Do not unexpectedly call an operator while he is working if not necessary; it is forbidden as well to frighten who is working and throw objects, even if just for fun.
- Watch out those present, especially the children!
- Make always sure that no people stand within the equipment's ray of action.
- Do not make people get on the machine.
- When the equipment is not needed, stop the vehicle's engine, park it on a flat ground with first speed and parking brake on, with the machine rested on the ground and power takeoff disengaged.
- Do not make any cleanings, lubrications, repairs or adjustments with running engine and lifted machine.
- Never use the machine in steep slopes which may jeopardize the equipment's stability.

SICMA declines all responsibility for a lack of compliance with these instructions.

STARTING UP

ATTACHMENT TO THE TRACTOR

It is necessary to read up this instruction manual and the manuals of the tractor and cardan shaft manufacturer.

All SICMA tillers have been manufactured to be attached to any tractor provided with hydraulic elevator and universal three-point hitch.

Before attaching the equipment to the tractor, set both on a flat and smooth ground and make sure that nobody is standing between them.

Move slowly the tractor towards the tiller by aligning the tractor elevator's arms to the two tiller hitches' lateral gudgeons; stop engine and pull parking brake.

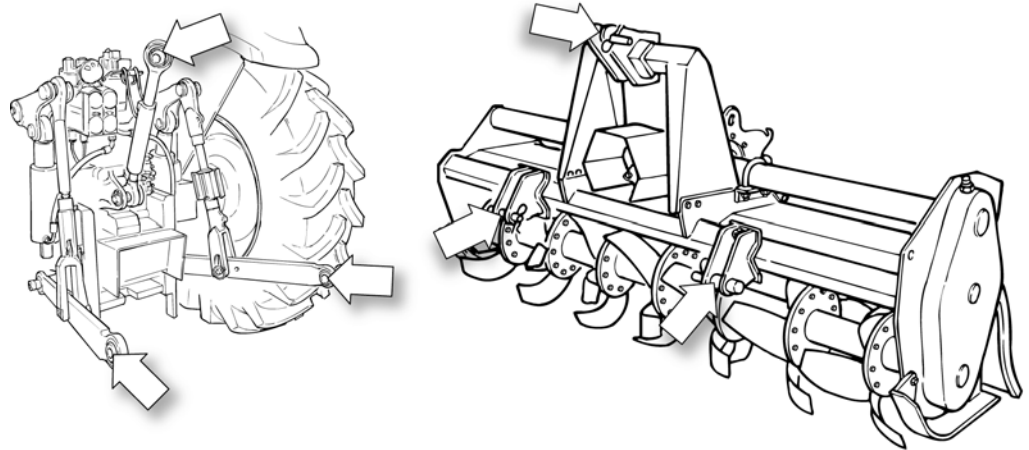

Picture 3

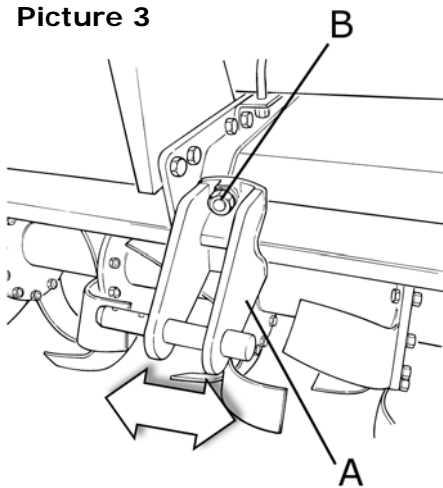

Picture 4

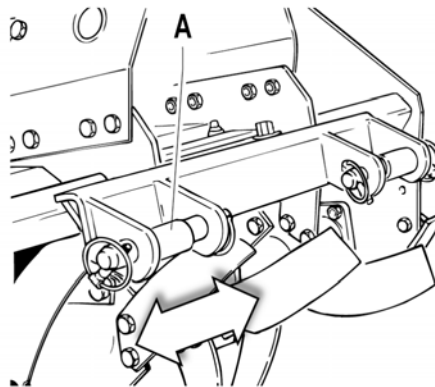

In some SICMA tillers it is possible to adjust the hitches position.

On **ZLL, CS, ST, SM, SP** tillers, adjustment can be made by loosening bolt **B** (picture 3) and modifying the position of plates **A**. Tighten strongly all bolts after regulation (ref. bolts and nuts tightening table) .

On **SA** and **SB** tillers the hitches regulation can be made by moving spacing bushings **A** (picture 4)

Once the hitches regulation is done, connect the lower arms by removing the release pins of the gudgeons placed on plates **A**, inserting the elevator bars into the arms centre and fastening them with the relevant release pins, which had been removed in precedence.

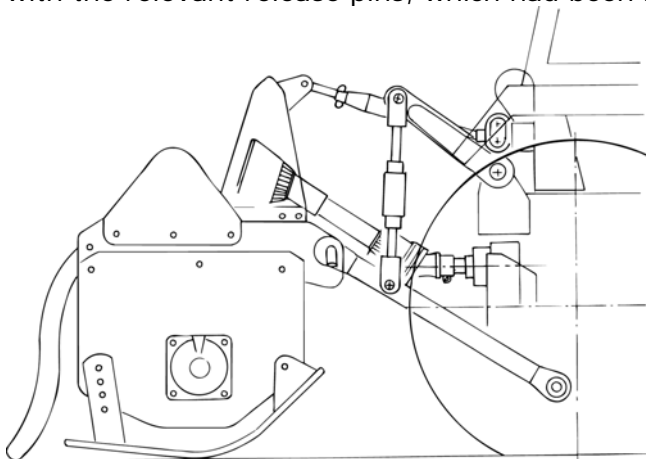

Connect, afterwards, the tractor tie rod to the third upper point by removing the pin located between the plates, inserting the tie rod itself and locking it with the pin.

Adjust the third point so that the upper part of the frame is parallel to the ground.

Lock all connection parts with the special sway chains or tie rods.

It is always good to make sure that the central group axis (sump/bevel gear pair) is parallel to the ground thus reducing the stresses on the power takeoff and extending the working life of the equipment.

 **Caution**

After executing the above-mentioned activities it is always good to check that all bolts and nuts of your tiller are tightened strongly (ref. bolts and nuts tightening table).

ATTACHMENT TO THE CARDAN SHAFT

Before assembling the cardan shaft, it is very important to check out that its number of revolutions and direction of rotation match those of the tractor. Moreover, read carefully the instruction manuals of the cardan shaft and the tractor manufacturers.

Before starting work, check the presence of the safety guards on the power takeoffs of the machine, the cardan shaft and the tractor. Check in particular that the safety guards cover the cardan shaft throughout its extension.

 **Caution**

When at their maximum extension, the safety guards' plastic hoses shall overlap of at least 1/3 of their length (LT). When in their maximum closing position, the minimum clearance allowed shall be of 1-2 cm (picture 5).

Picture 5

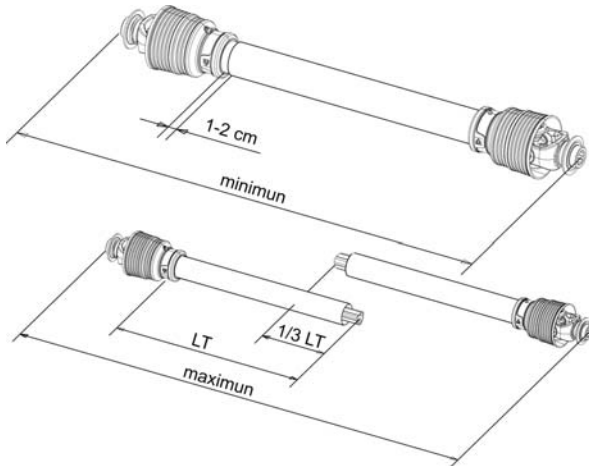

Check out that the cardan shaft minimum and maximum length are the ones required by the machine-tractor coupling.

Should problems arise, contact a skilled repair shop or the cardan retailer. After installation, secure safety guards both to the tractor and the machine using the special chains and make sure that they pivot freely. If the cardan shaft is equipped with other safety devices, such as a pair limiter or freewheels, be sure to install them on the machine side. As for the cardan use and maintenance refer to the relevant booklet.

COVER ADJUSTMENT

The rear cover can be adjusted in height to better compact the round and make it flat. The adjustment can be made by releasing chain **A** (picture 8) from upper hook **B** and inserting it back to the needed height.

Picture 8

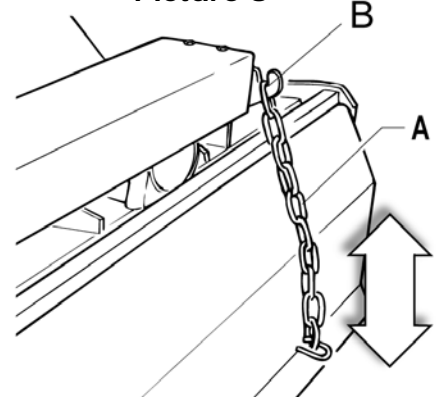

 **Danger**

These operations shall be made only on working ground and only after having stopped the engine, disengaged the power takeoff and pulled the parking brake. If necessary, lift the machine from the ground but, in order to avoid risks for people, place it on supports thus preventing any injuries that might be caused by its sudden fall.

WORKING DEPTH ADJUSTMENT

The machine's working depth is determined by the position of side skids.

Lifting the skids the work depth increases, lowering them it decreases; it is important to lift or lower skids equally on both sides.

To adjust the working depth on **SA, SB, SF, SD, SM-F, SM-F, SHV-SHF-SHE, CS, ST** and **SM** tillers, screw out and remove screw **A** (picture 6) and adjust the height of the skid through holes **B**. At the end of these operations tighten screws strongly (ref. bolts and nuts tightening table)

To adjust the working depth on **SP** and **RG** tillers, loosen screw nut **A** (picture 7) and make regulation rod **B** slide up to needed height. At the end of these operations tighten screws strongly.

Picture 6

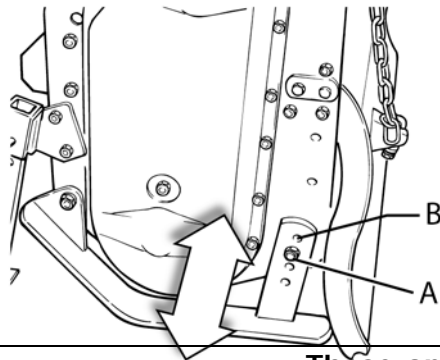

Picture 7

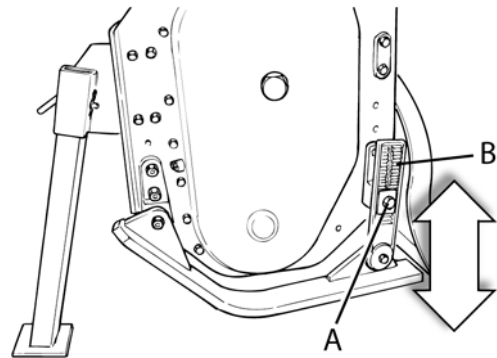

 **Danger**

These operations shall be made only on working ground and only after having stopped the engine, disengaged the power takeoff and pulled the parking brake. If necessary, lift the machine from the ground but, in order to avoid risks for people, place it on supports thus preventing any injuries that might be caused by its sudden fall.

SPEED GEAR

ST speed gear, SM speed gear, SM-F, SP and **RG** tillers are provided with speed gear and it is possible to modify the rotor speed independently from the speed of the tractor power takeoff. Higher speeds improve the soil working speed but produce a faster wear of rotating parts.

- To change speed on **ST speed gear, SP** and **RG** tillers leave cover **A** (picture 9) from gearbox and invert gear wheels **B** and **C** inside it; it is possible to obtain two more speeds by replacing the assembled gears with those put into the cover.
- To change speed on **SM speed gear** and **SM-F** tillers just move lever **A** (picture 10) following the indications shown on the gearbox (1, 2, 3).

As for the gear's speed, refer to the stickers put on the machine.

Picture 9

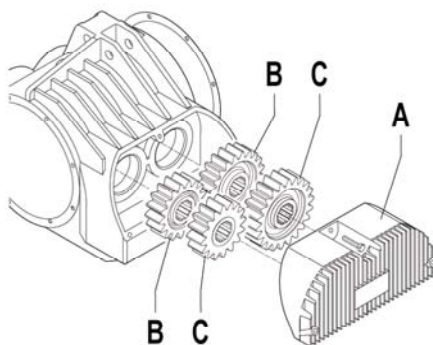

Picture 10

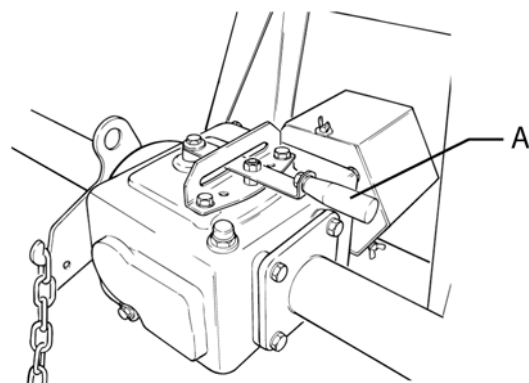

 **Danger**

Do not act on gears before having stopped the engine, disengaged the power takeoff, pulled the parking brake and placed the machine on the ground.

CHAIN TENSION

SA, SB, SF chain, ZLL, CS chain and **SP chain** tillers are equipped with chain drive.

As for **SA, SB, ZLL** and **CS chain** models, the chain tension adjustment takes place during assembly; for eventual further regulations during the machines' use please contact SICMA authorized repair shops.

As for **SP chain** tiller, the chain tension adjustment is made through a tightener (picture 11). Eventual excessive clearances can be regulated by loosening lock nut **A** and screwing screw **B** to its fullest without forcing (up to the chain maximum tension), then loosening screw **B** of about two turns (thus avoiding excessive chain tension). Keeping screw **B** standstill, tighten lock nut **A** strongly (ref. bolts and nuts tightening table).

Picture 11

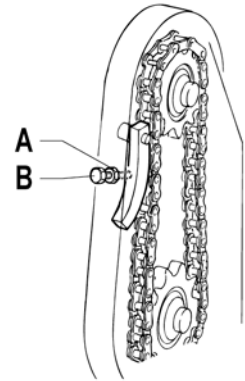

 **Danger**

Adjustment of the chain shall be made with standstill machine after having stopped the engine and disengaged the power takeoff.

SIDE SHIFT ADJUSTMENT

SA, SB, SF, SD, SHV-SHF-SHE and **SM-F** tillers are provided with side shift.

As for **SA** and **SB** models, when a side shift is required loosen nuts **A** (picture 12) to make the main frame slide as needed; tighten nuts strongly after regulation (ref. bolts and nuts tightening table).

SF and **SD** models are not equipped with hydraulic side shift, therefore shift can be made through the special screw **A** (picture 13); for adjustment, insert crank **B** in trailing tang **C** and swing it up to needed shift.

Picture 12

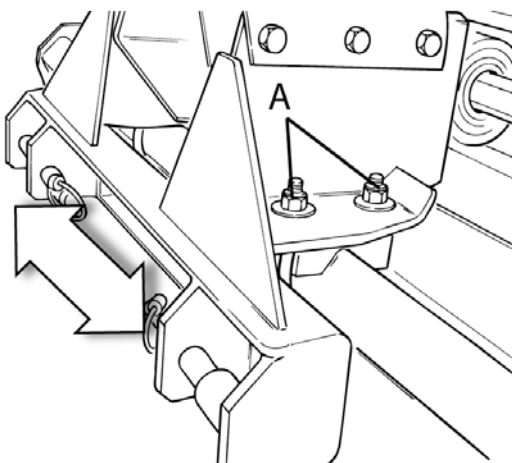

Picture 13

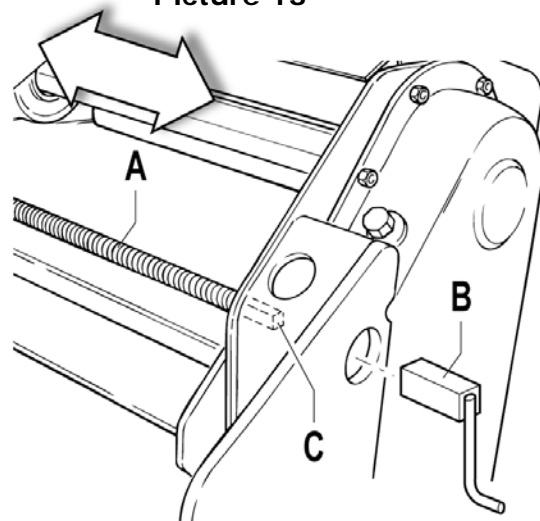

SH tiller side shift

SHV-SHF-SHE tiller is a model equipped with automatic hydraulic side shift, useful in case of workings which require a shift of the machine's body with respect to the tractor axis. Models SHF (orchard version) and **SHE** (intermediate version), are equipped with a hitch which is shifted from the tractor axis.

INTER-LINES TILLAGE

To set in action the automatic hydraulic side shift during inter-lines tillage:

- Release feeler **A** (picture 14)
- Extract the locking gudgeon **B** (picture 15)
- Move lever **C** (picture 16) in position **2**

NORMAL TILLAGE

With machine in standard position, insert the locking gudgeon **B** (picture 15) and move lever **C** in position **1** (picture 16); hook feeler **A** (picture 14)

Picture 14

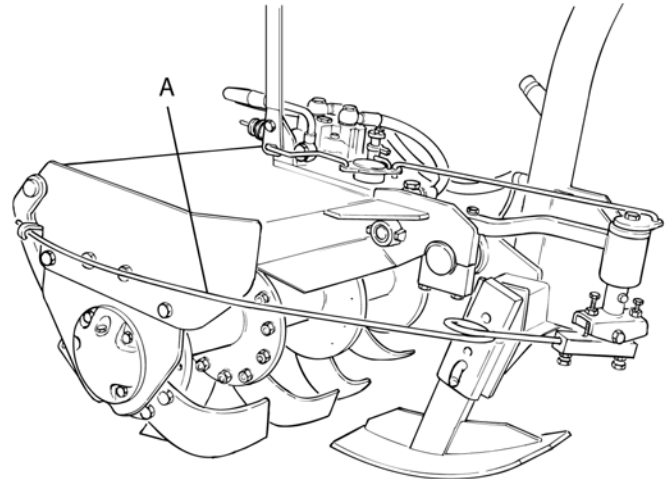

Picture 15

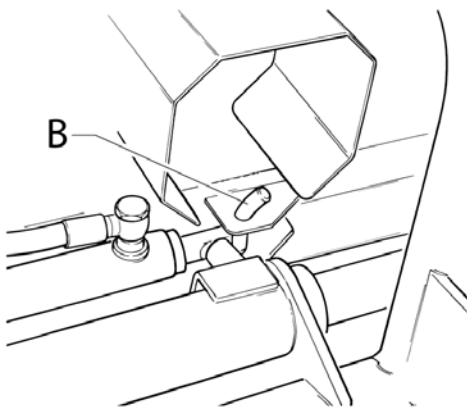

Picture 16

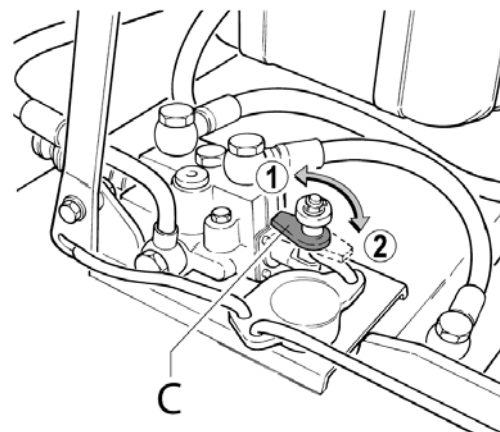

Picture 17

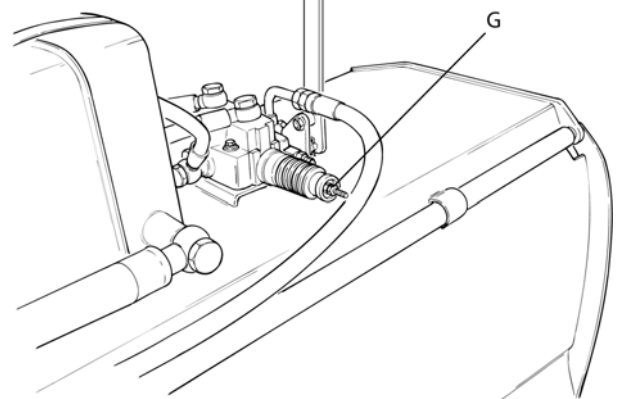

The machine automatic shift is made through pressure on the feeler. The feeler's resistance and its sensibility can be adjusted through spring **G** (picture 17) placed behind the deviating device. It is also possible to adjust the feeler height through screws **C** and **D** (picture 18) and its amplitude (ray of action) through screw **E** (picture 18).

Moreover, **SHV-SHF-SHE** tiller is equipped with a lever (**F** - picture 19) for the manual setting of hydraulic side shift.

Picture 18

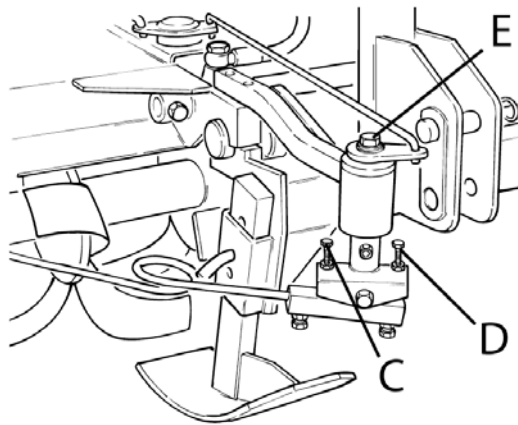

Picture 19

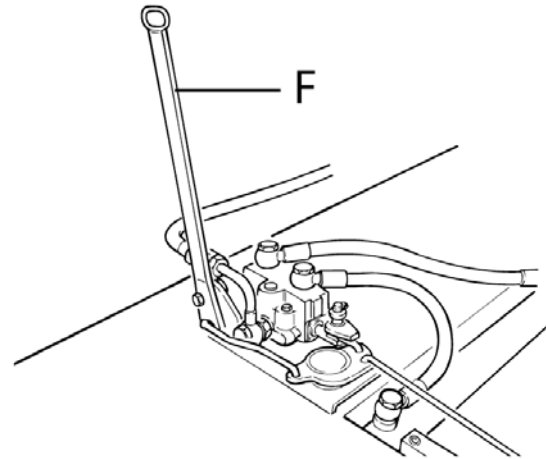

STARTING UP

Now that all setting up operations are completed, your machine is ready to be used; after reaching the work place we advise to engage power takeoff only after having lifted the machine of a few centimetres with the tractor elevator. After this, it is possible to start engine, engage power takeoff, drop the machine down to work position and start using it.

ROAD TRANSPORT

While transporting the machine it is very important to follow the road traffic code of the country where you circulate.

SET ASIDE

If the tiller will not be used for a long period of time, we advise to:

- 1 Wash the machine accurately and dry it.
- 2 Check out all equipment and replace eventual damaged or worn parts.
- 3 Tighten strongly all bolts and nuts (ref. bolts and nuts tightening table).

Make an accurate greasing and finally protect the whole machine with a tarpaulin and put it in a dry place.

MAINTENANCE

Maintenance is a fundamental operation to extend life and performances of any agricultural vehicle; taking care of the machine grants you not only a good work execution, but also a longer life of the whole equipment and a greater safety on the workplace.

The operating times indicated on this manual have just an informative character and are referred to normal conditions of use; they can thus undergo variations according to the type of service, to the more or less dusty environment, to seasonal factors, etc



-
- **Before injecting lubricating grease into the nipples, clean them accurately to prevent mud, dust or other foreign matters from mixing up with grease, thus diminishing the lubrication effect**
 - **When making oil feed or change it is better to use the same oil type, in order to avoid mixing oils with different features.**
 - **When executing maintenance activities, keep the machine rested on the round in horizontal position, stop engine and disengage power takeoff.**
 - **After the first working hours check that all bolts and nuts are tightened strongly, especially the hoes' ones; remember also to check often all the machine safety guards.**
-

FIRST CHECK

After the first 50 hours of work change oil in the gear case and check all bolts and nuts tightening.

EVERY 8 HOURS OF WORK

- Grease the rotor support through the lubricating nipples **A** (picture 20) of **CS, SA, SD** and **SF** tillers.
- Grease the cardan shaft spider of every model of tillers.

EVERY 50 HOURS OF WORK

- Check oil level of sump/bevel gear pair (**A** - picture 21).
- Check oil level of the lateral drive (**A** - picture 22),
- Check oil level of the rotor support on **ST, SM, SP, RG, SHV-SHF-SHE** and **SM-F** tillers (**A** - picture 23).

If necessary feed with SAE EP 80W90 oil.

- On **SHV-SHF-SHE** tillers, check oil of their hydraulic system (cap **B** – picture 24) and of their mast (cap **C** – picture 24)

If necessary feed with DS68 hydraulic oil.

- Check that all bolts and nuts are strongly tightened, especially the hoes' ones.

EVERY 500 HOURS OF WORK

- It is necessary to change oil of the group sump/bevel gear pair, of the lateral drive and of the rotor support (**ST, SM, SP, RG, SHV-SHF-SHE, SM-F**); use only SAE EP 80W90 oil.

For this kind of maintenance please contact the nearest SICMA authorized repair shop.

Picture 20

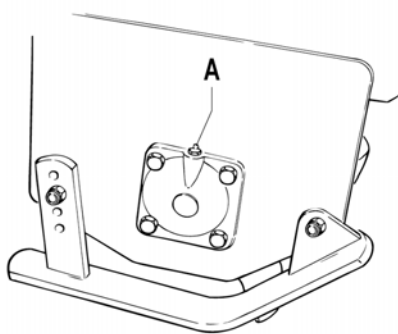

Picture 21

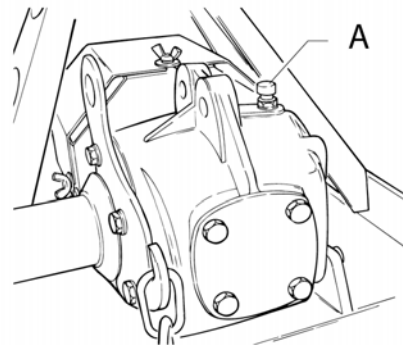

Picture 22

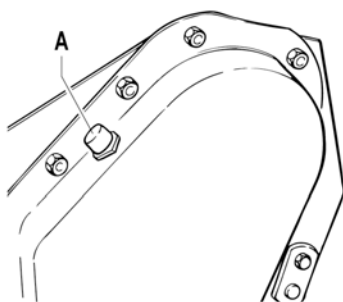

Picture 23

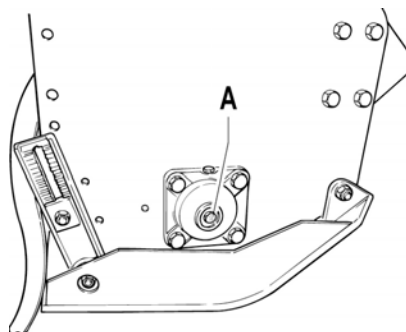

Picture 24

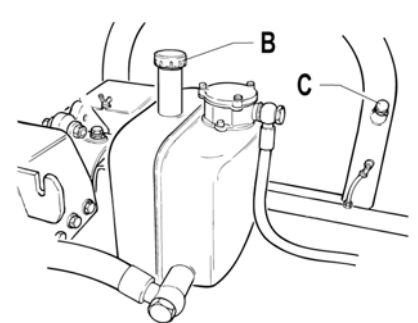

 **Caution**

Get rid of exhaust oil in compliance with the relevant rules of the country where you operate. It is thus forbidden to pour it on the ground.

 **Danger**

Before executing maintenance activities on the machine, stop engine, disengage power takeoff, pull parking brake and place the equipment on the ground.

HOES REPLACEMENT

To assure a perfect functioning of the machine, check often that its hoes are in good condition and perfectly fixed by the locking bolts; in case they are broken or bent replace them with new spare parts, remembering to keep always the original position.

CS, ST, SM, SP, RG, SF, SD, SHV-SHF-SHE and **SM-F** tillers are equipped with 6 hoes per flange; on **CS, ST** and **SM** models it is possible to reduce their number to 4 when particular soil conditions require this modification.

 **Danger**

Before starting the hoes replacement activities, stop engine, pull parking brake and disengage power takeoff; lift then the tiller with the tractor elevator and place it on supports to avoid an accidental fall.

Pay attention to hoes bolts **A** (picture 25): these ones must be assembled with their screwhead on the hoes side and their washer and nut on the flange side; bolts, thus, will not unscrew while the machine is being used.

If you have to replace a sequence of more than one hoe, do it one by one in order to keep as better as you can the original helical-run position (picture 26).

Picture 25

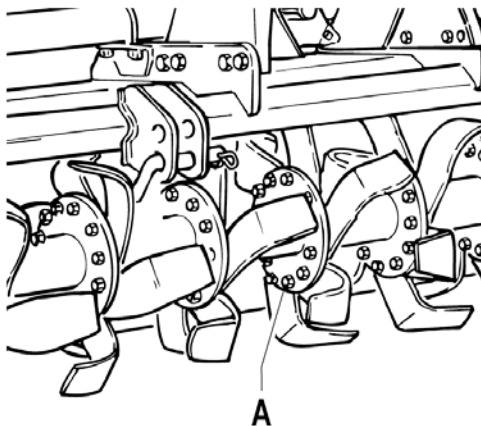

Picture 26

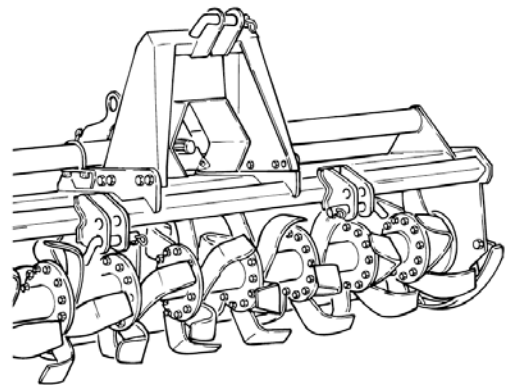

SPARE PARTS ORDERING

To order spare parts, please consult the catalogue.

Request of spare parts must be made to the retailer or to the nearest service centre and must always be completed with the following information:

- Type and width of the equipment.
- Code number of the needed spare part. Lack of this number, you can replace it with the number of the table where the part is represented and the correspondent reference.
- Denomination of the needed part and desired quantity.
- Chosen transportation. When this item is not specified, the retailer or service centre, even devoting many cares to this service, do not answer for eventual shipping delays due to acts of God. Transport charges must always be paid by the addressee.

Type: FRESATRICE
Mod.: ZLL 080 • 090 • 100 • 110 • 120 • 130 • 140
Rev.: 02/2006
Draw: 1/1

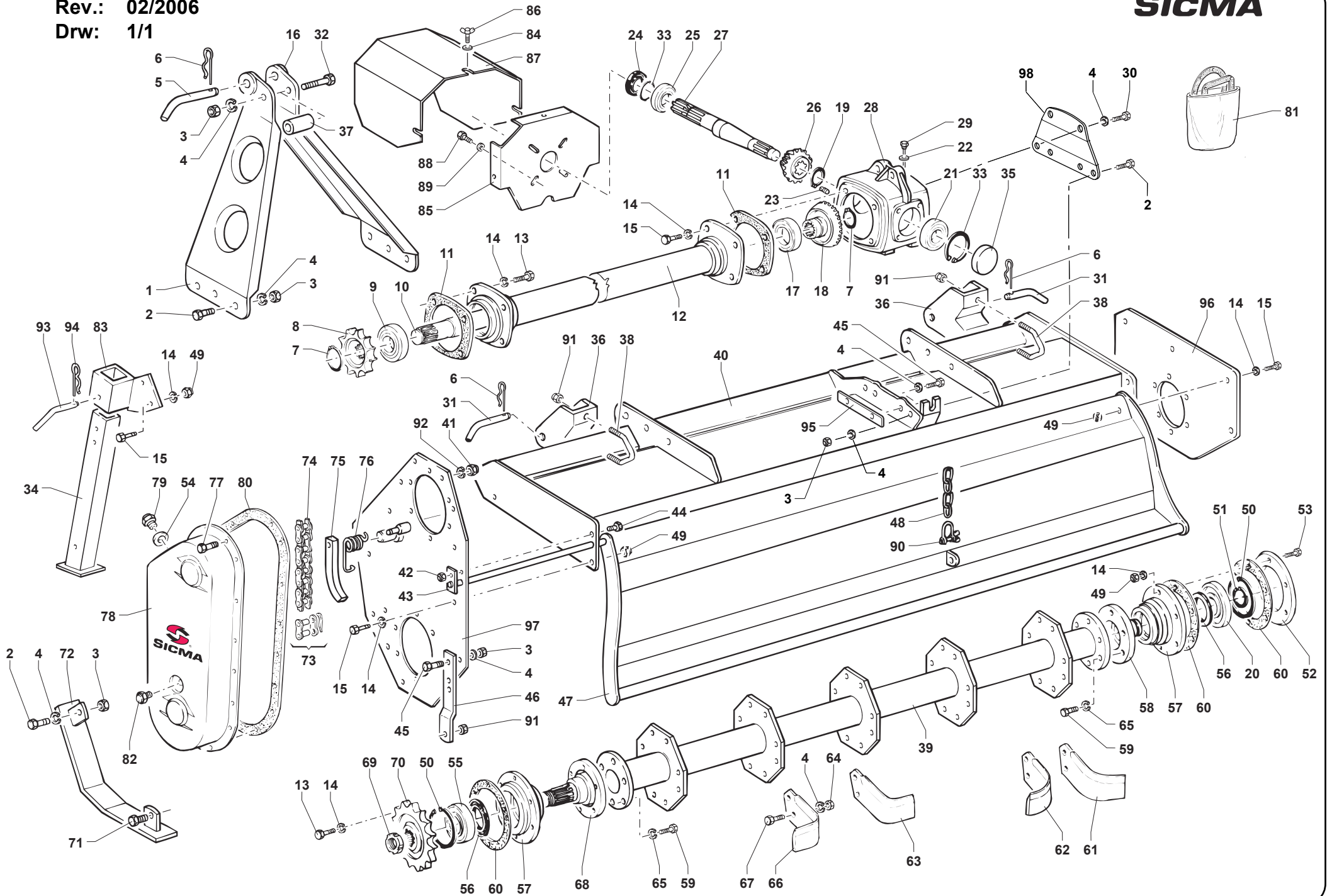

RIF.	CODICE	DENOMINAZIONE	DESCRIPTION	BENENNUNG	DESIGNATION
1	4001329	Attacco 3° punto superiore sx	Junction for 3 rd point	Verbindungstück 3° punkt	Support 3° point
2	31512030	Vite M12x1,75x30 UNI 5739	Screw M12x1,75x30 UNI 5739	Schraube M12x1,75x30 UNI 5739	Vis M12x1,75x30 UNI 5739
3	34100012	Dado M12 PG UNI 5587	Nut M12 PG UNI 5587	Mutter M12 PG UNI 5587	Ecrou M12 PG UNI 5587
4	34121012	Rondella grower ø 12 UNI 1751	Washer ø 12 UNI 1751	Scheibe ø 12 UNI 1751	Rondelle ø 12 UNI 1751
5	4301589	Perno 3° punto superiore ø 19	Pin ø 19	Bolzen ø 19	Axe ø 19
6	6351004	Copiglia a "R" ø 4	Split pin "R" ø 4	Splint "R" ø 4	Coupille "R" ø 4
7	6320035	Seeger E ø 35	Circlip E ø 35	Seegersicherung E ø 35	Bague d'arrêt E ø 35
8	4701359	Ingranaggio conduttore Z=11	Driving gear Z=11	Zahnrad Z=11	Engrenage Z=11
9	2226307	Cuscinetto 6307 2RS	Bearing 6307 2RS	Lager 6307 2RS	Roulement 6307 2RS
10	4211201	Albero corona ZLL-080	Shaft ZLL-080	Welle ZLL-080	Arbre ZLL-080
10	4211202	Albero corona ZLL-090	Shaft ZLL-090	Welle ZLL-090	Arbre ZLL-090
10	4211203	Albero corona ZLL-100	Shaft ZLL-100	Welle ZLL-100	Arbre ZLL-100
10	4211204	Albero corona ZLL-110	Shaft ZLL-110	Welle ZLL-110	Arbre ZLL-110
10	4211205	Albero corona ZLL-120	Shaft ZLL-120	Welle ZLL-120	Arbre ZLL-120
10	4211206	Albero corona ZLL-130	Shaft ZLL-130	Welle ZLL-130	Arbre ZLL-130
10	4211207	Albero corona ZLL-140	Shaft ZLL-140	Welle ZLL-140	Arbre ZLL-140
11	4781265	Guarnizione supp. trasmissione	Gasket	Dichtung	Garniture
12	4001280	Supporto albero corona ZLL-080	Support ZLL-080	Halterung ZLL-080	Support ZLL-080
12	4001281	Supporto albero corona ZLL-090	Support ZLL-090	Halterung ZLL-090	Support ZLL-090
12	4001282	Supporto albero corona ZLL-100	Support ZLL-100	Halterung ZLL-100	Support ZLL-100
12	4001283	Supporto albero corona ZLL-110	Support ZLL-110	Halterung ZLL-110	Support ZLL-110
12	4001284	Supporto albero corona ZLL-120	Support ZLL-120	Halterung ZLL-120	Support ZLL-120
12	4001285	Supporto albero corona ZLL-130	Support ZLL-130	Halterung ZLL-130	Support ZLL-130
12	4001286	Supporto albero corona ZLL-140	Support ZLL-140	Halterung ZLL-140	Support ZLL-140
13	30210020	Vite M10x1,5x20 UNI 5739	Screw M10x1,5x20 UNI 5739	Schraube M10x1,5x20 UNI 5739	Vis M10x1,5x20 UNI 5739
14	34021010	Rondella grower ø 10 UNI 1751	Washer ø 10 UNI 1751	Scheibe ø 10 UNI 1751	Rondelle ø 10 UNI 1751
15	30010025	Vite M10x1,5x25 UNI 5739	Screw M10x1,5x25 UNI 5739	Schraube M10x1,5x25 UNI 5739	Vis M10x1,5x25 UNI 5739
16	4001328	Attacco 3° punto superiore dx	Junction for 3 rd point	Verbindungstück 3° punkt	Support 3° point
17	2106307	Cuscinetto 6307	Bearing 6307	Lager 6307	Roulement 6307
18	17265-01	Corona conica Z=19	Ring bevel gear Z=19	Kegelrandkranz Z=19	Couronne conique Z=19
19	6320030	Seeger E ø 30	Circlip E ø 30	Seegersicherung E ø 30	Bague d'arrêt E ø 30
20	2106308	Cuscinetto 6308	Bearing 6308	Lager 6308	Roulement 6308
21	2730305	Cuscinetto 30305	Bearing 30305	Lager 30305	Roulement 30305
22	6402716	Guarnizione tappo	Gasket	Dichtung	Garniture
23	6481600	Tappo scarico olio	Plug	Stopfen	Bouchon
24	6203562	Paraolio ø 35x62x10 PP	Oil seal ø 35x62x10 PP	Oelabdichtung ø 35x62x10 PP	Pare-huile ø 35x62x10 PP
25	2106007	Cuscinetto 6007	Bearing 6007	Lager 6007	Roulement 6007
26	17265-00	Pignone conico Z=13	Bevel pinion Z=13	Kegelritzel Z=13	Pignon conique Z=13
27	4211212	Albero input Z=6	Shaft Z=6	Welle Z=6	Arbre Z=6
28	16565-00	Carter coppia conica	Gearbox	Gehäuse	Carter
29	65316-05	Tappo sfiato con livello	Plug	Stopfen	Bouchon
30	31512025	Vite M12x1,75x25 UNI 5739	Screw M12x1,75x25 UNI 5739	Schraube M12x1,75x25 UNI 5739	Vis M12x1,75x25 UNI 5739
31	4301590	Perno 3° punto inferiore ø 22	Pin ø 22	Bolzen ø 22	Axe ø 22
32	31312080	Vite M12x1,75x80 UNI 5739	Screw M12x1,75x80 UNI 5739	Schraube M12x1,75x80 UNI 5739	Vis M12x1,75x80 UNI 5739
33	6310062	Seeger I ø 62	Circlip I ø 62	Seegersicherung I ø 62	Bague d'arrêt I ø 62
34	4001234	Piedino di appoggio	Foot	Fuss	Pied
35	6100062	Cappellotto di chiusura ø 62	Cover ø 62	Deckel ø 62	Couvercle ø 62
36	4001278	Attacco 3° punto inferiore dx=sx	Junction for 3 rd point	Verbindungstück 3° punkt	Support 3° point
37	4531701	Distanziale 3° punto	Spacer	Distanzstück	Entretoise
38	4201202	Cravatta di bloccaggio	"U" Bolt	Halter	Etrier
39	4001236	Rotore a 4 zappe ZLL-080	Rotor ZLL-080	Rotor ZLL-080	Rotor ZLL-080
39	4001274	Rotore a 4 zappe ZLL-090	Rotor ZLL-090	Rotor ZLL-090	Rotor ZLL-090
39	4001237	Rotore a 4 zappe ZLL-100	Rotor ZLL-100	Rotor ZLL-100	Rotor ZLL-100
39	4001238	Rotore a 4 zappe ZLL-110	Rotor ZLL-110	Rotor ZLL-110	Rotor ZLL-110
39	4001239	Rotore a 4 zappe ZLL-120	Rotor ZLL-120	Rotor ZLL-120	Rotor ZLL-120
39	4001240	Rotore a 4 zappe ZLL-130	Rotor ZLL-130	Rotor ZLL-130	Rotor ZLL-130
39	4001241	Rotore a 4 zappe ZLL-140	Rotor ZLL-140	Rotor ZLL-140	Rotor ZLL-140
40	4001301	Telaio ZLL-080	Frame ZLL-080	Gestell ZLL-080	Cadre ZLL-080
40	4001302	Telaio ZLL-090	Frame ZLL-090	Gestell ZLL-090	Cadre ZLL-090
40	4001303	Telaio ZLL-100	Frame ZLL-100	Gestell ZLL-100	Cadre ZLL-100
40	4001304	Telaio ZLL-110	Frame ZLL-110	Gestell ZLL-110	Cadre ZLL-110
40	4001305	Telaio ZLL-120	Frame ZLL-120	Gestell ZLL-120	Cadre ZLL-120
40	4001306	Telaio ZLL-130	Frame ZLL-130	Gestell ZLL-130	Cadre ZLL-130
40	4001307	Telaio ZLL-140	Frame ZLL-140	Gestell ZLL-140	Cadre ZLL-140
41	34000008	Dado M8 PG UNI 5587	Nut M8 PG UNI 5587	Mutter M8 PG UNI 5587	Ecrou M8 PG UNI 5587
42	34106008	Dado autob. M 8 PG alto UNI 7473	Stop nut M 8 PG	Sperrmutter M 8 PG	Ecrou de sûreté M 8 PG
43	4002336	Perno coperchio ZLL-080	Bonnet pin ZLL-080	Bolzen deckel ZLL-080	Axe capot ZLL-080
43	4002337	Perno coperchio ZLL-090	Bonnet pin ZLL-090	Bolzen deckel ZLL-090	Axe capot ZLL-090
43	4002338	Perno coperchio ZLL-100	Bonnet pin ZLL-100	Bolzen deckel ZLL-100	Axe capot ZLL-100
43	4002339	Perno coperchio ZLL-110	Bonnet pin ZLL-110	Bolzen deckel ZLL-110	Axe capot ZLL-110
43	4002340	Perno coperchio ZLL-120	Bonnet pin ZLL-120	Bolzen deckel ZLL-120	Axe capot ZLL-120
43	4002341	Perno coperchio ZLL-130	Bonnet pin ZLL-130	Bolzen deckel ZLL-130	Axe capot ZLL-130
43	4002342	Perno coperchio ZLL-140	Bonnet pin ZLL-140	Bolzen deckel ZLL-140	Axe capot ZLL-140
44	30208020	Vite M8x1,25x20 UNI 5739	Screw M8x1,25x20 UNI 5739	Schraube M8x1,25x20 UNI 5739	Vis M8x1,25x20 UNI 5739
45	31512035	Vite M12x1,75x35 UNI 5739	Screw M12x1,75x35 UNI 5739	Schraube M12x1,75x35 UNI 5739	Vis M12x1,75x35 UNI 5739
46	4831202	Asta regolazione slitta	Skid adjusting rod	Regulierstange-schlitten	Tige de réglage-glossière
47	4001222	Coperchio ZLL-080	Bonnet ZLL-080	Deckel ZLL-080	Capot ZLL-080
47	4001270	Coperchio ZLL-090	Bonnet ZLL-090	Deckel ZLL-090	Capot ZLL-090
47	4001223	Coperchio ZLL-100	Bonnet ZLL-100	Deckel ZLL-100	Capot ZLL-100
47	4001224	Coperchio ZLL-110	Bonnet ZLL-110	Deckel ZLL-110	Capot ZLL-110
47	4001225	Coperchio ZLL-120	Bonnet ZLL-120	Deckel ZLL-120	Capot ZLL-120
47	4001226	Coperchio ZLL-130	Bonnet ZLL-130	Deckel ZLL-130	Capot ZLL-130
47	4001227	Coperchio ZLL-140	Bonnet ZLL-140	Deckel ZLL-140	Capot ZLL-140

Type: FRESATRICE

Mod.: ZLL 080 • 090 • 100 • 110 • 120 • 130 • 140

Rev.: 02/2006

Tab: 1/1

Pag. 2/2

RIF.	CODICE	DENOMINAZIONE	DESCRIPTION	BENENNUNG	DESIGNATION
48	4508702	Catena coperchio 10 maglie	Chian	Kette	Chaîne
49	34000010	Dado M10 PG UNI 5587	Nut M10 PG UNI 5587	Mutter M10 PG UNI 5587	Ecrou M10 PG UNI 5587
50	6310090	Seeger I ø 90	Circlip I ø 90	Seegersicherung I ø 90	Bague d'arrêt I ø 90
51	6320040	Seeger E ø 40	Circlip E ø 40	Seegersicherung E ø 40	Bague d'arrêt E ø 40
52	4141242	Coperchio supporto esterno	Bonnet	Deckel	Capot
53	30210030	Vite M10x1,5x30 UNI 5739	Screw M10x1,5x30 UNI 5739	Schraube M10x1,5x30 UNI 5739	Vis M10x1,5x30 UNI 5739
54	34027022	Rondella alluminio ø 22	Washer ø 22	Scheibe ø 22	Rondelle ø 22
55	2006308	Cuscinetto 6308	Bearing 6308	Lager 6308	Roulement 6308
56	6205572	Paraolio ø 55x72x10 PP	Oil seal ø 55x72x10 PP	Oelabdichtung ø 55x72x10 PP	Pare-huile ø 55x72x10 PP
57	4701202	Supporto rotore	Support	Halterung	Support
58	4701203	Mozzo supporto rotore	Hub	Nabe	Moyeu
59	30212030	Vite M12x1,75x30 UNI 5739	Screw M12x1,75x30 UNI 5739	Schraube M12x1,75x30 UNI 5739	Vis M12x1,75x30 UNI 5739
60	4788744	Guarnizione supporto rotore	Gasket	Dichtung	Garniture
61	4811281	Zappa curva dx	Right blade	Rechtes messer	Couteau droite
62	4811282	Zappa curva sx	Left blade	Linkes messer	Couteau gauche
63	4811283	Zappa a squadra dx	Right square blade	Rechtes winkelmesser	Couteau droit à équerre
64	34101012	Dado M12 PF UNI 5587	Nut M12 PF UNI 5587	Mutter M12 PF UNI 5587	Ecrou M12 PF UNI 5587
65	34021012	Rondella grower ø 12 UNI 1751	Washer ø 12 UNI 1751	Scheibe ø 12 UNI 1751	Rondelle ø 12 UNI 1751
66	4811284	Zappa a squadra sx	Left square blade	Linkes winkelmesser	Couteau gauche à équerre
67	33612035	Vite M12x1,25x35 fil. 20 mm	Screw M12x1,25x35	Schraube M12x1,25x35	Vis M12x1,25x35
68	4721201	Mozzo lato trasmissione	Hub	Nabe	Moyeu
69	34127035	Ghiera autobl. ø 35 GUP	Self locking metal ring ø 35 GUP	Selbssperrendnutmutter ø 35 GUP	Collier autobloquant ø 35 GUP
70	4701221	Ingranaggio condotto Z=17	Gear Z=17	Zahnrad Z=17	Engrenage Z=17
71	31512040	Vite M12x1,75x40 UNI 5739	Screw M12x1,75x40 UNI 5739	Schraube M12x1,75x40 UNI 5739	Vis M12x1,75x40 UNI 5739
72	4001244	Slitta dx=sx	Skid	Schlitten	Glissière
73	6700254	Maglia giunzione	Link	Kettenglied	Maille de jonction
74	6700025	Catena ASA "80-S" 40 maglie	Chian ASA "80-S"	Kette ASA "80-S"	Chaîne ASA "80-S"
75	4001275	Tendicatena	Chain adjuster	Kettenspanner	Tendeur de chaîne
76	4211263	Molla per tendicatena	Spring	Feder	Ressort
77	30208020	Vite M8x1,25x20 UNI 5739	Screw M8x1,25x20 UNI 5739	Schraube M8x1,25x20 UNI 5739	Vis M8x1,25x20 UNI 5739
78	4141200	Carter trasmissione Sicma	Cover	Deckel	Couvercle
79	3442022	Tappo valvola M 22x1,5	Plug M 22x1,5	Stopfen M 22x1,5	Bouchon M 22x1,5
80	4781264	Guarnizione carter trasmissione	Gasket	Dichtung	Garniture
81	4091280	Sacchetto guarnizioni	Gasket set	Dichtungssatz	Séries garniture
82	3444014	Tappo livello olio M14x1,5	Plug M14x1,5	Stopfen M14x1,5	Bouchon M14x1,5
83	4001682	Supporto piedino	Support	Halterung	Support
84	34118008	Rondella ø 8 fascia larga UNI 6593	Washer ø 8	Scheibe ø 8	Rondelle ø 8
85	4131295	Supporto protezione giunto	Support	Halterung	Support
86	33108020	Vite ad alette M8x1,25x20 UNI 5449	Screw M8x1,25x20 UNI 5449	Schraube M8x1,25x20 UNI 5449	Vis M8x1,25x20 UNI 5449
87	4131294	Protezione giunto	Protecting cover	Schutzkragen	Protecteur
88	31508016	Vite M8x1,25x16 UNI 5739	Screw M8x1,25x16 UNI 5739	Schraube M8x1,25x16 UNI 5739	Vis M8x1,25x16 UNI 5739
89	34112008	Rondella piana ø 8 UNI 6592	Washer ø 8 UNI 6592	Scheibe ø 8 UNI 6592	Rondelle ø 8 UNI 6592
90	3685016	Grillo 5/16" ø 8 mm	Clevis	Schwebende Gerüst	Manille
91	34106012	Dado autobloc. M12 PG alto UNI 7473	Nut M12 PG UNI 7473	Mutter M12 PG UNI 7473	Ecrou M12 PG UNI 7473
92	34021008	Rondella grower ø 8 UNI 1751	Washer ø 8 UNI 1751	Scheibe ø 8 UNI 1751	Rondelle ø 8 UNI 1751
93	4236115	Perno bloccaggio piedino	Pin	Bolzen	Pivot
94	6351003	Spina a "R" ø 3	Split pin "R" ø 3	Splint "R" ø 3	Coupille "R" ø 3
95	4131217	Distanziale fissaggio scatola	Spacer	Distanzstück	Entretoise
96	4131331	Piastra lato esterno	External side plate	Platte	Plaque
97	4001312	Piastra lato trasmissione	Gearing side plate	Platte	Plaque
98	4931230	Piastra supporto gruppo	Gearbox support	Platte	Plaque

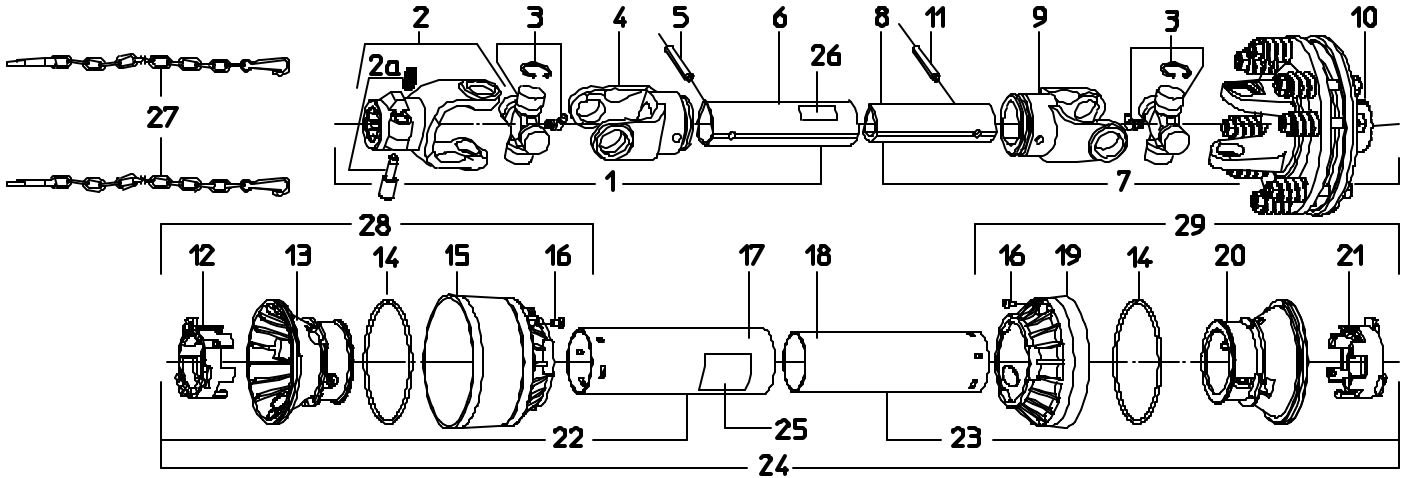

14	2	STIFFENING RING	1213233	29	1	FDO CONE ASSEMBLY (implement end)	1784247
13	1	OUTER TUBE RIGID CONE	1784201	28	1	STANDARD CONE ASSEMBLY (tractor end)	1784233
12	1	TUBE BEARING (outer tube)	1784210	27	2	ANTIROTATION CHAIN	1006065
11	1	Ø8x55 1485DIN ROLL PIN (inner tube)	6330855	26	1	INNER DECAL	1140003
10	1	FDO/4 CLUTCH 2 FRICTION DISCS	1334030	25	1	OUTER DECAL	1140001
9	1	INNER TUBE YOKE	1704029	24	1	COMPLETE PROTECTION	90SE4028
8	1	INNER TUBE	1525036	23	1	HALF INNER PROTECTION	90XE4028
7	1	HALF INNER SHAFT	3223400	22	1	HALF OUTER PROTECTION	90SX4028
6	1	OUTER TUBE	1524036	21	1	TUBE BEARING (inner tube)	1784211
5	1	Ø8x60 1485DIN ROLL PIN (outer tube)	6330860	20	1	INNER TUBE RIGID CONE	1784202
4	1	OUTER TUBE YOKE	1704027	19	1	SOFT EXTRA SHORT CONE	1784207
3	2	CROSS ASSEMBLY	1004020	18	1	INNER TUBE SHIELD	1872028
2a	1	PUSH PIN KIT	1581038	17	1	OUTER TUBE SHIELD	1773028
2	1	YOKE ASSEMBLY (TRACTOR END)	1024010	16	2	PIN FOR STOP ROTATION	1784212
1	1	HALF OUTER SHAFT	2223400	15	1	SOFT STANDARD CONE	1784203

DET.	QTY	DESCRIPTION	CODE	DET.	QTY	DESCRIPTION	CODE
B		Aggiunti codici particolari 2a - 28 - 29 (codici 2a - 28 - 29 addati)					
A		Protezione CP era WB (shield configuration CP was WB)					
rev.		description	trans date				

customer	customer part no:		drawn A CAVALLETTI	date: 02/07/2002
note:	weight (kg/lbs) ---/---		scale no A4	REV.1 B
SPARE PARTS LAY OUT		c da Saletti 66D41 Atessa ICH - Italy		
AX4 500/748 1024010-034030 CP SE		part no. 8223400		

IF DRIVESHAF IS TOO LONG

HOW TO SHORTEN THE DRIVELINE

After the machine has been hitched to the three-point coupling of the tractor, it should be lifted and lowered to check that the driveline is the correct length. If the driveline is too short and tends to slip out of place, it must be replaced with a longer one.

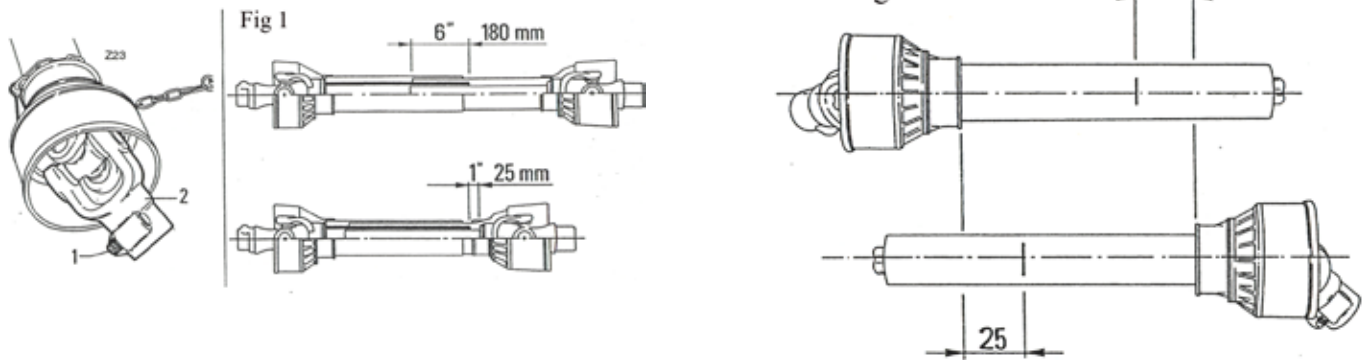

If the driveline is too long, it should be shortened in the following way:

- Attach the implement to the tractor, set the brakes and switch the engine off.
- Separate the two halves of the driveline. Insert the female part into the tractor PTO and the male part into the machine PTO, checking that the position is correct by means of the lock pins.
- Position the two halves of the driveline together, keeping them parallel.
- Using a felt-tip pen, mark the place where the two halves must be shortened, measuring 1" (25mm) from the beginning of each half, as shown in fig. 2.

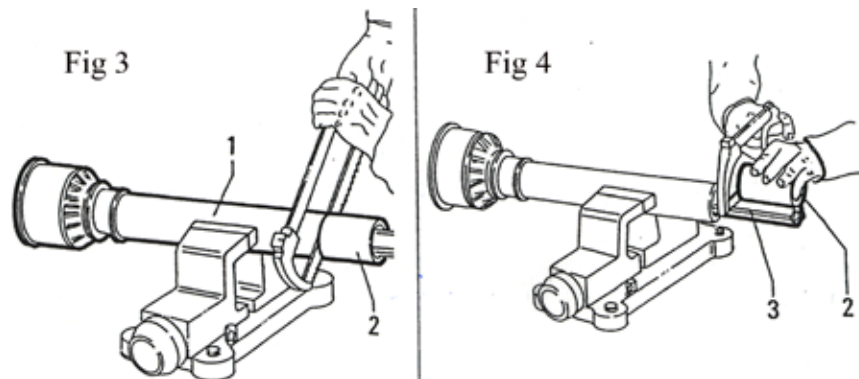

- First cut shield '1' fig. 3 and, use the part '2' as a reference to cut the splined shaft.
- Proceed in the same way for the second half.
- Trim and chamfer the two cut ends of the driveline and clean off all burrs and shavings.
- Grease the two profiles and join the two halves of the driveline together again.
- Mount the driveline and check that it's length is correct by lifting and lowering the machine.

The shaft must not reach the end of the tube or project from this. It is particularly important the dimensions from Fig. 1 are followed. Minimum of 1" (25mm) extension when connected to the implement & tractor, and a minimum of 6" of contact when fully extended.



CAUTION



Contact your nearest dealer or a specialized retail outlet if the driveline must be replaced with a longer one, since this must belong to the same power category and possess the same characteristics. An unsuitable driveline could easily break.



WARNING



Consult the driveline manufacturer's use and maintenance manual in case of doubt.

DISTRIBUTOR

TRAM SALES LTD.
10757 - 182 Street
Edmonton, AB T5S 1J5 Canada
Ph: (780) 484-2231
Fx: (780) 484-0817

DEALER STAMP

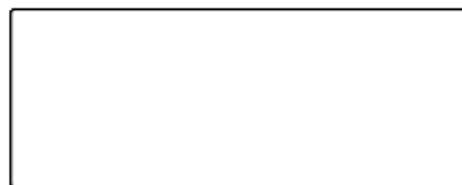

SICMA SPA
VIA VAL DI FORO
66010 MIGLIANICO - (CHIETI) - ITALIA
USCITA A-14 PE SUD - FRANCAVILLA