

CE

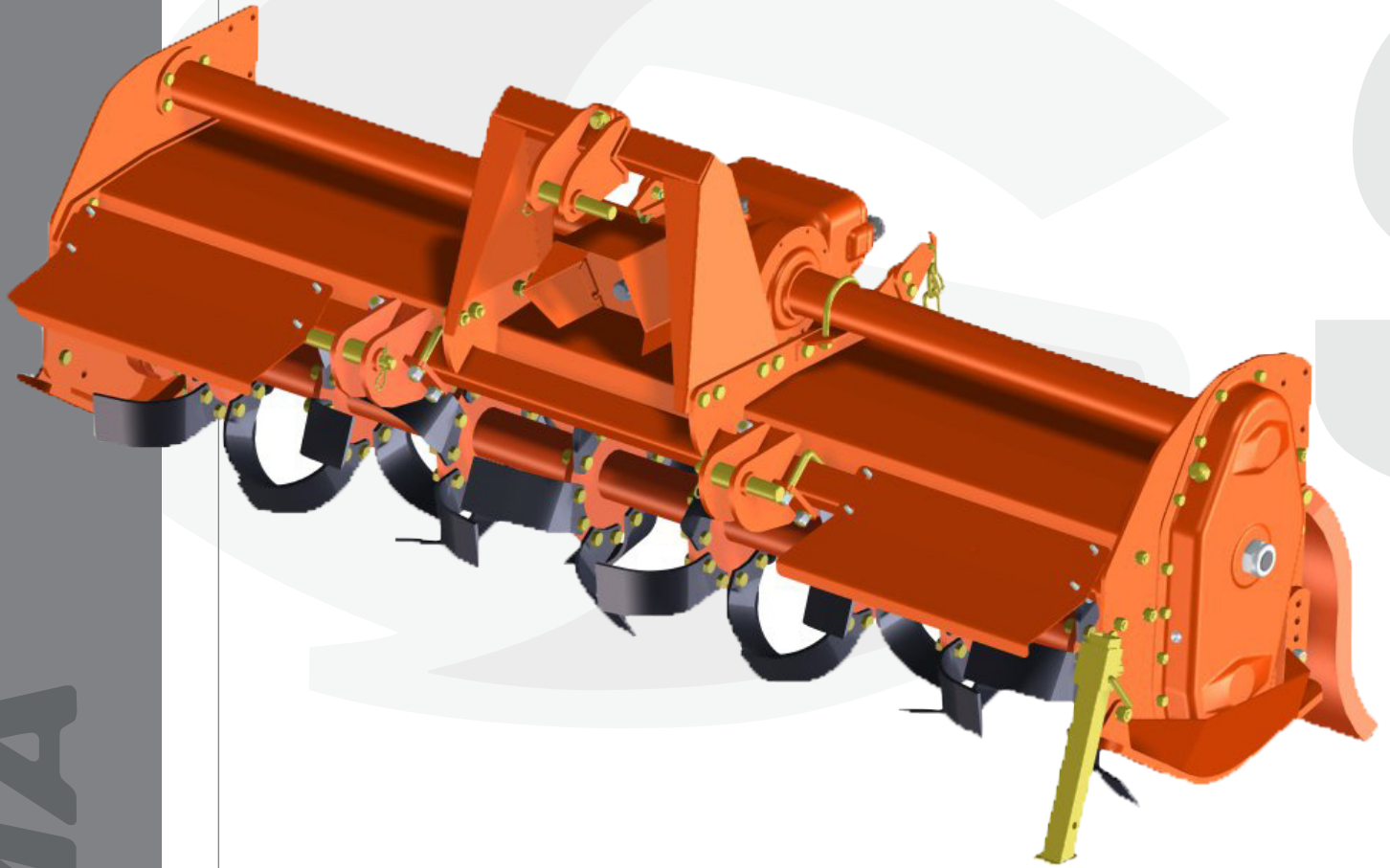

RM Tiller

USE AND MAINTENANCE MANUAL

903844002~01



TRANSLATION OF ORIGINAL INSTRUCTIONS

MADE IN ITALY



INDEX

1.	INTRODUCTION	5
1.1	SOME NOTES REGARDING THE USER MANUAL	5
1.2	DECLARATION OF CONFORMITY	6
1.3	LIST OF RESIDUAL RISKS	7
1.4	DELIVERY LETTER	8
1.5	TILLER IDENTIFICATION AND MANUAL CODE	9
1.6	GENERAL DELIVERY NOTES	10
1.7	DECLARED USE	11
1.8	TILLER COMPOSITION	12
1.9	STANDARD AND OPTIONAL SET-UPS	12
2.	SAFETY	14
2.1	DEFINITIONS (UNI EN ISO 12100-1:2009)	14
2.2	CONVENTIONAL SYMBOLS	14
2.3	SAFETY PRESCRIPTIONS	15
2.4	OPERATOR REQUISITES	15
2.5	CLOTHING AND PPE	16
2.6	MACHINE USE	16
2.7	SAFETY DEVICES	17
2.8	REASONABLY PREDICTABLE INCORRECT USE	17
2.9	ZERO ENERGY STATE	17
2.10	POSITION OF PICTOGRAMS ON THE MACHINE	18
3.	UNLOADING AND UNPACKING THE TILLER	21
3.1	TILLER PROTECTED BY HEAT-SHRINKABLE FILM	21
3.2	TILLER IN WOODEN CRATE	22
4.	TECHNICAL FEATURES	24
5.	START-UP	26
5.1	CARDAN SHAFT CONNECTION	26
5.2	3-POINT HITCH CONNECTION	28
5.3	ROAD TRANSPORT	29
6.	ADJUSTMENTS	29
6.1	ROTATION SPEED CHANGE	29
6.2	CLUTCH ADJUSTMENT	30
6.3	WORKING HEIGHT ADJUSTMENT	30
6.4	COVERS ADJUSTMENT	31
6.5	MACHINING	31
7.	STOPS	33
8.	ROUTINE MAINTENANCE	35
8.1	CONTROL AND REPLACEMENT OF THE OIL IN THE GEARBOX UNIT	36
8.2	CONTROL AND REPLACEMENT OF THE OIL IN THE LATERAL DRIVE SUMP	37
8.3	CONTROL AND REPLACEMENT OF THE OIL IN THE EXTERNAL ROTOR LATERAL SUPPORT	37
8.4	GREASING	37
8.5	REPLACING HOES/BLADES	37
8.6	CARDAN SHAFT	38
9.	CLEANING	38
10.	STORAGE AND WINTERING	39
11.	SCRAPPING	39



12.	QUICK CONSULTATION TABLES	40
12.1	COUPLING TORQUE TABLE	40
12.2	TROUBLESHOOTING	40
12.3	LUBRICATION INTERVALS	41
13.	SPARE PARTS	42
14.	WARRANTY	42



Congratulations on your purchase of the RM Tiller

The RM Tiller is manufactured by SICMA S.p.A, which has been producing agricultural machines for over 40 years.

The RM Tiller has all safety and quality requisites required for this type of equipment.

Remember that to obtain the best performance and make the best of the production features, it is necessary to know the instructions and information contained in this manual and follow the same.

1. INTRODUCTION

1.1 SOME NOTES REGARDING THE USER MANUAL

Remember that the USER MANUAL is not an accessory of the tiller but is an INTEGRAL part and a SAFETY MEASURE (EN 12100-1).

For this reason:

- kept in a good state
- it must be kept near to the equipment
- pass it to any operator user, maintenance technician, handler or successive owner.

In this way, the tiller can be used in the best way for all functions for which it has been manufactured and in maximum safety.

The manual must not be damaged, it must remain integral (do not rip the sheets), must be kept away from humidity and heat. During consultation it must not be covered in grease or its legibility deteriorated.

If this manual is lost or damaged, ask for a copy from the Manufacturer or nearest Dealer.

To ease consultation, the manual has been divided into parts so that every phase is described well.

With these arrangements, SICMA intends to unmistakably call the operator's attention to the dangerous situations that may occur.



1.2 DECLARATION OF CONFORMITY

The machine is delivered accompanied by the following Declaration of Conformity.

CE DECLARATION OF CONFORMITY

pursuant to Directive 2006/42/CE

The Company

Sicma s.p.a. – C. da Cerreto, 39 – 66010 Miglianico (Ch) – Italy
Tél.: +39 0871 95841 – Fax +39 0871 950295
e-mail: info@sicma.it – http://www.sicma.it

declares under his own responsibility that the machine:

Type: TILLER
Model: RM
Serial number:

is conform with the essential health and safety requisites of Directive 2006/42/EC.

To verify the conformity with the above Directive, the following have been consulted:

EN Harmonised Standards:

- UNI EN ISO 4254 – 1:2006, EN ISO 4254 – 5:2009, UNI EN ISO 12100 – 2:2009

National and International technical Specifications and Standards:

- ISO 11684:1995, ISO 13852:1996, UNI 9456:1989.

The person authorised to fill-in the Technical File is Mr. Lorenzo Aurora (Sole Director)



Miglianico, 15-03-2011

Lorenzo Aurora
SOLE DIRECTOR

1.3 LIST OF RESIDUAL RISKS

Even though SICMA has done everything possible to be in line with state-of-the-art safety and in compliance with all Directives, Laws and Standards available, some residual risks still exist:

- CUT/CRUSHING HAZARD DUE TO CONTACT WITH TOOLS (rotor)
- ENTANGLEMENT/Dragging HAZARD (rotor and Cardan shaft)
- OVERTURNING/CRUSHING HAZARD (tiller)
- BURNS HAZARD (gearbox)
- CUT/SHEARING HAZARD (rear covers)

Therefore, anyone using the machine or performing maintenance on the same, must be trained and aware of the fact that dangers exist and in spite the use of protections to reduce them, it is not possible to eliminate them totally.

The staff assigned to these operations must always have the use and maintenance manual available for consultation.

The use and maintenance manual states all indications requested from point 1.7.4 (User instructions) of Attachment 1 of the Machinery Directive and specific request is made to comply with the prescriptions, so as not to cause accidents that can injure persons.



1.4 DELIVERY LETTER

The tiller has been manufactured in compliance with the 2006/42/CE Directive,
and has been designed in compliance with the guide lines of the Technical Standards relative to the tillers, specifically UNI EN ISO 4254-1:2010 and UNI EN ISO 4254-5:2009.

Therefore, the machine does not represent a danger for the operator if used according to the instructions in this manual and on condition that the safety devices are kept constantly efficient.

This form attests receipt of the tiller:

- the safety devices are present
- this manual has been delivered

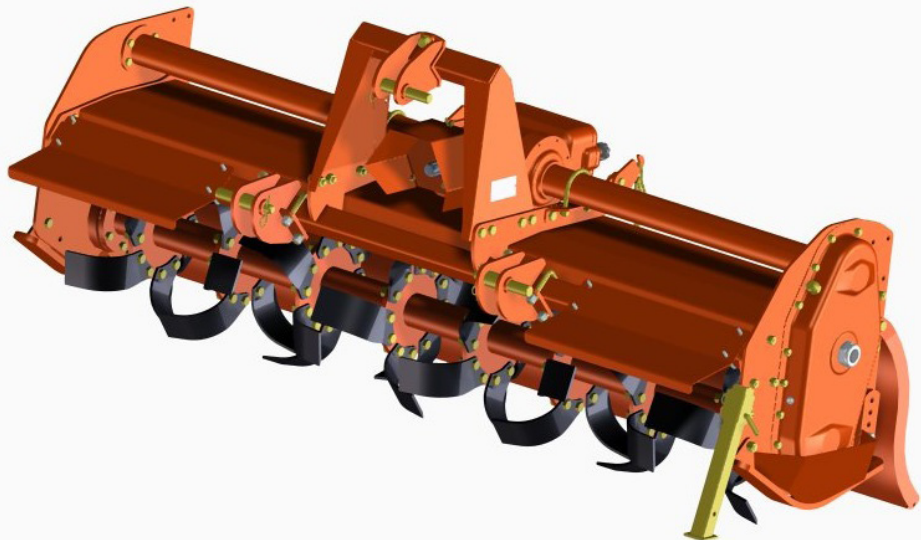

SICMA INFORMS THAT ANY MODIFICATION OR TAMPERING OF THE TILLER OR ANY OPERATION PERFORMED IN DISAGREEMENT WITH THAT WRITTEN IN THIS MANUAL, ESPECIALLY FAILURE TO COMPLY WITH THE SAFETY PROVISIONS, AS WELL AS MAKING THE WARRANTY NULL AND VOID, RELIEVES SICMA FROM ANY LIABILITY FOR DAMAGE TO OBJECTS AND INJURY TO PERSONS.

Some of the devices described in this manual may not be present on your machine, depending on the chosen set up and the market of destination.

It must be remembered that all technical values refer to the standard tiller (see Chap. 4 “Technical Features”) and the drawings and any other document delivered along with the tiller are the property of SICMA, which reserves all rights and reminds that they cannot be made available to third parties without its written approval.

Therefore, any reproduction, even partial, of the text and illustrations is prohibited.

The information, descriptions and illustrations contained in this manual reflect the state of the art of the machine at the moment it was put on the market.

The Manufacturer reserves the right, at any time, to apply modifications to the machinery for technical or commercial reasons. Such modifications do not oblige the Manufacturer to intervene on machines sold up until that moment, nor to consider this publication inadequate.

Any integration that the Manufacturer will consider opportune to supply later on must be preserved together with the manual and be considered an integral part of the same.



1.5 TILLER IDENTIFICATION AND MANUAL CODE

For any after-sales requests or information regarding the tiller, contact SICMA or its after-sales centres always stating the model and the serial number stated on the plate.

The identification code of this manual is written on the cover. Write the number in a different place so that if this manual is lost or damaged, another copy can be requested from SICMA or the nearest dealer by also stating the serial number visible in the marking.



SICMA CE

SICMA SPA - C.da Carreto, 39 - 66100 Miglianico (Ch) - Italy
Tel: +39 0871 95841 Fax: +39 0871 950295 - Info@sicma.it - www.sicma.it

Type	Fresatrice
Model	RM210
Serial No	00216
Year	2011
Mass	445 Kg
Input	540 rpm

MADE IN ITALY



1.6 GENERAL DELIVERY NOTES

1

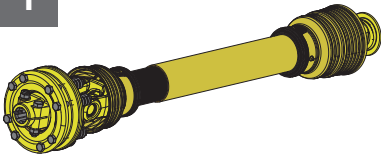

The tiller and its parts and/or accessories are normally delivered by lorry or container.

On receipt of the machine, check that:

- the supply corresponds with the order specifications (see transport document or packing-list)
- there is no damage to the tiller or accessories
- in the event of damage or missing pieces, inform the SICMA or its area representatives, the carrier or its insurance immediately in detail and/or with photos
- the spare parts or equipment supplied are sometimes in separate containers.

2



The machine is delivered by SICMA equipped with the following supplies:

- 1 - CARDAN SHAFT
- 2 - TILLER USE AND MAINTENANCE MANUAL
- 3 - CARDAN SHAFT USE AND MAINTENANCE MANUAL
- 4 - CE DECLARATION OF CONFORMITY

3



4

CE DECLARATION OF CONFORMITY
pursuant to Directive 2006/42/CE

The Company
Sicma s.p.a. - C. da Cerreto, 39 - 66010 Miglianico (Ch) - Italy
Tel: +39 0871 95041 - Fax: +39 0871 950295
e-mail: info@sicma.it - http://www.sicma.it

declares under his own responsibility that the machine:

Type: TILLER
Model: RM
Serial number:

is conform with the essential health and safety requisites of Directive 2006/42/EC.

To verify the conformity with the above Directive, the following have been consulted:
EN Harmonised Standards:
- UNI EN ISO 4254 - 1:2006, EN ISO 4254 - 5:2009, UNI EN ISO 12100 - 2:2009

National and International technical Specifications and Standards:
- ISO 11884:1995, ISO 13852:1996, UNI 9456:1989.

The person authorised to fill-in the Technical File is Mr. Lorenzo Aurora (Sole Director)

Miglianico, 15-03-2011

SICMA

Lorenzo Aurora
SOLE DIRECTOR

1.7 DECLARED USE

The RM Tiller has been designed expressly to work land and has been developed with the sole purpose of loosening, turning and oxygenating the land in order to prepare it for sowing.

It has been manufactured to be coupled to tractors that can support the weight of the tiller, with hydraulic lifting device and universal three point hitch and to be activated by the tractor PTO via Cardan transmission.

USE ENVIRONMENT

The tiller works:

- in open fields, on non friable land, not excessively stony with a maximum gradient of 3°
- in environments with a temperature from 0° ÷ 50° C.

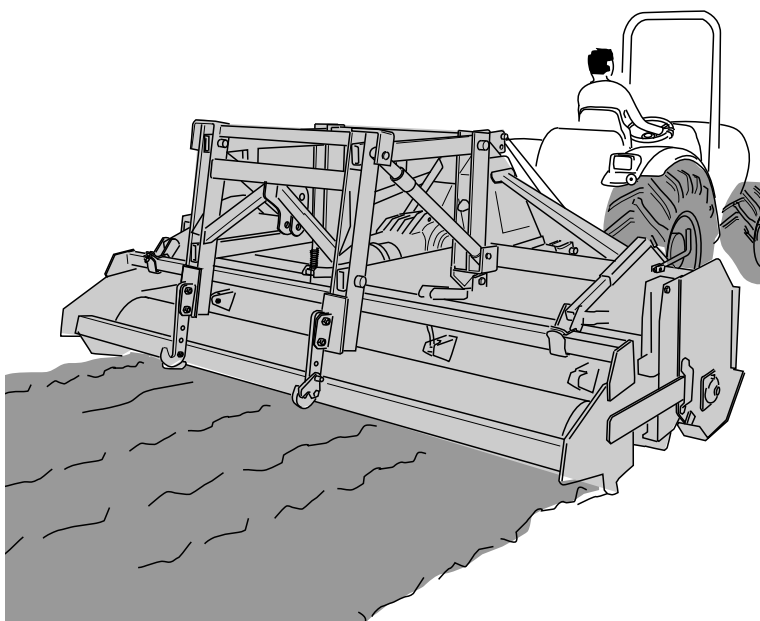

IMPROPER USE

Any use different to that declared is to be considered improper.

Sometimes the operator uses the tiller incorrectly, below find some examples the must NOT BE PERFORMED.

The operator must not:

- connect the tiller to a Cardan shaft with greater or smaller power
- work in reverse gear compressing the earth with hood press
- couple the tiller to vehicles of unsuitable power or weight
- assemble the tiller without securing the rebound tie rods of the three-point hitch of the tractor's elevator
- lift the equipment when the PTO is rotating
- make curves or reverse with the tiller lowered.

Remember that the tiller is developed only with the purpose of the declared use.

Any other use is to be considered improper.

1.8 TILLER COMPOSITION

- | | |
|----|-------------------------|
| 1 | Chassis |
| 2 | Lower point hitches |
| 3 | Upper three-point hitch |
| 4 | Cardan shaft protection |
| 5 | Third point mast |
| 6 | Rotor |
| 7 | Hoes |
| 8 | Side skids |
| 9 | Drive sump |
| 10 | Bonnet |

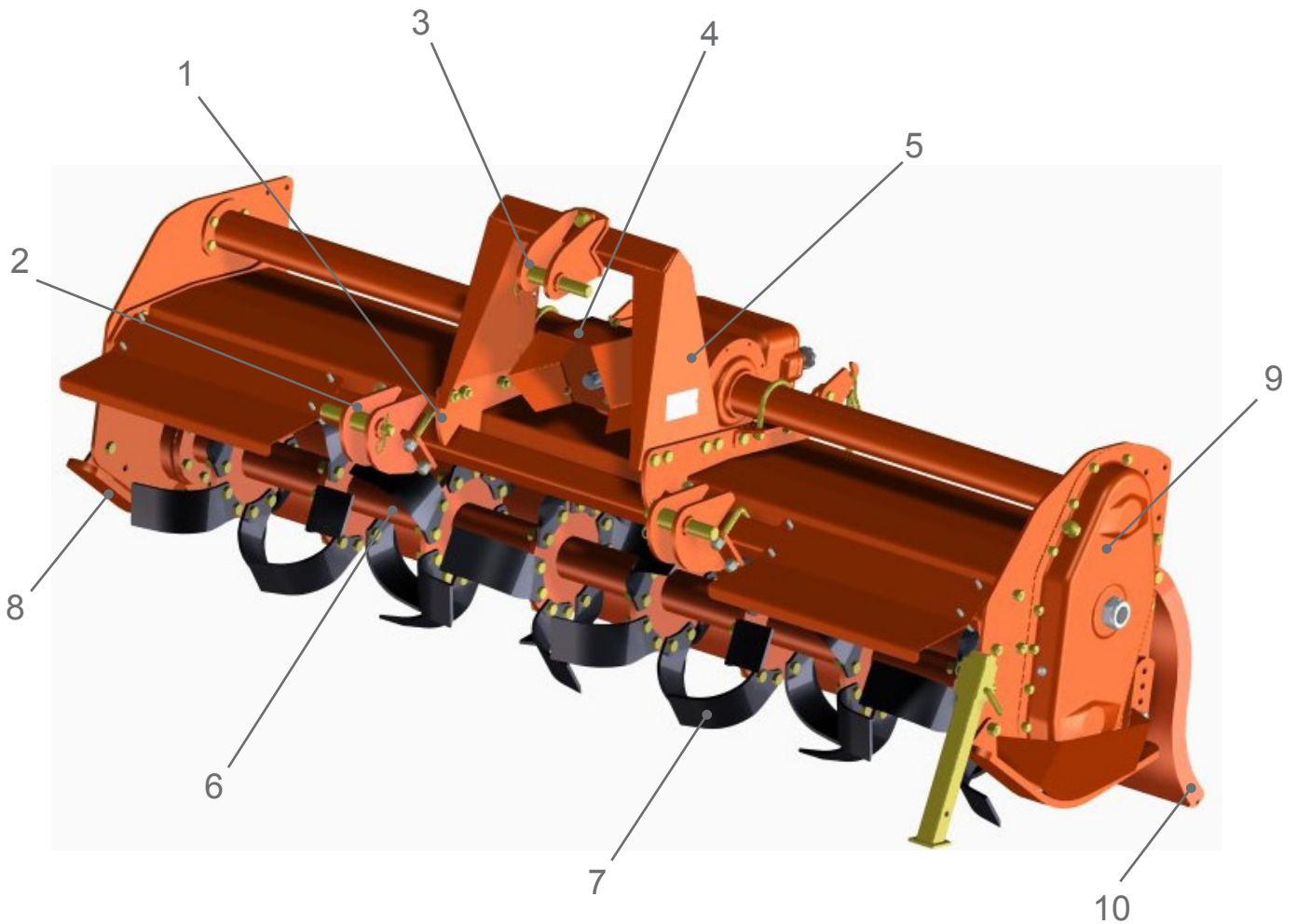

1.9 STANDARD AND OPTIONAL SET-UPS

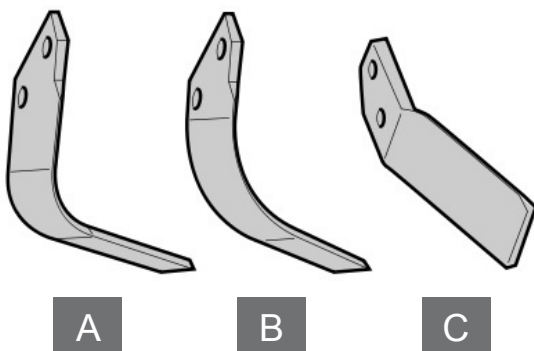

TYPES OF TOOLS

A - SQUARE HOE

B - CURVED HOE

C - BLADE WITH 2 HOLES

TYPES OF ROTOR

The purpose of the rotor is to work the earth in order to reduce the sods into smaller pieces, keeping the earth soft. Depending on the different features of earth to be worked, SICMA has developed and offers various types of rotor:

ROTOR

A

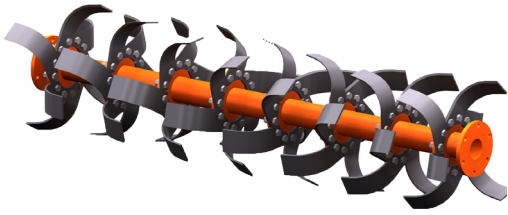

A - STANDARD ROTOR: for land in normal conditions

B

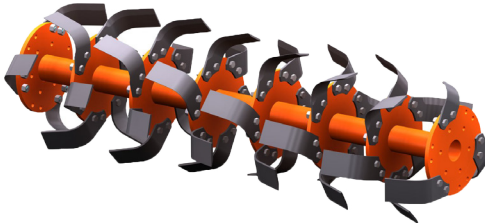

B - PUGLIA ROTOR: has the end hoes facing inwards and is recommended when working near to plants, avoiding damage to the roots

C

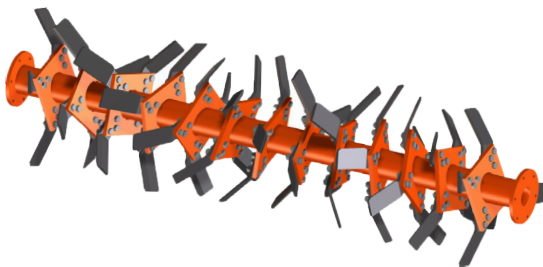

C - BLADE ROTOR: for wet and hard land

D

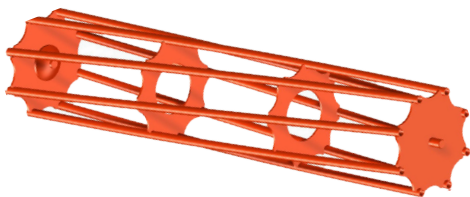

D - CAGE ROLLER: for dry land with average moisture and in the presence of small stones

E

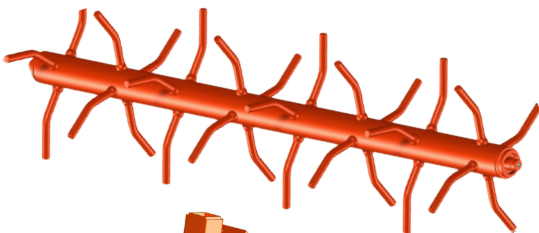

E - SPIKED ROLLER: for stony, argillaceous land or with high level of humidity

F

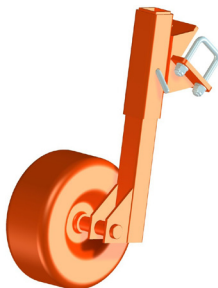

F - FRONT WHEELS: for a further working height adjustment

G



G - CRUSHER: for grinding and conveying sods



2. SAFETY

During consultation of this use and maintenance manual and on the equipment itself, it is possible to find several symbols whose meanings are illustrated below.

2.1 DEFINITIONS (UNI EN ISO 12100-1:2009)

DANGER:

A potential source of physical injury or damage to health.

DANGEROUS AREA:

Any area within and/or in proximity of a machine in which the presence of a person constitutes a risk for the safety and health of the same.

The dangerous area is the area around the machine (attached to the tractor) up to a distance of 1 metre.

EXPOSED PERSON:

any person that is totally or partially inside a dangerous area.

CRITICAL AREA

The critical area is that between the tractor and the equipment (Cardan shaft area).

2.2 CONVENTIONAL SYMBOLS



ATTENTION GENERAL HAZARD

Informs the staff assigned that the operation described has the risk of physical injury if not performed with respect to the Safety Standards.



NOTE

Informs the staff assigned of information whose content is of relevant consideration and importance.



WARNING

Informs the staff assigned of information whose content can cause slight injury to persons or damage to the machine if not respected.



MACHINE OPERATOR OR DRIVER

Identifies qualified staff, i.e. with specific skills, as the operations are completely manual, therefore refer to the preparation and sensitivity of the machine driver to obtain the best qualitative results. It is therefore prohibited for the operator to perform operations that are the responsibility of the maintenance technician.



MECHANICAL MAINTENANCE STAFF

Qualified technician able to intervene on mechanical parts in order to make all regulations, maintenance interventions and repairs necessary.



EXTRAORDINARY INTERVENTIONS

Any maintenance interventions highlighted by the symbol at the side are to be requested from the manufacturer or authorised workshops.



PERSONAL PROTECTIONS (PPE)

The presence of one of the symbols at the side imposes the use of the corresponding PPE by the operator, as the risk of accident is implicit.



RECOMMENDATION

It refers to a work mode experimented on field, knowing well that every operator will develop his own way of operating.



2.3 SAFETY PRESCRIPTIONS

Even though SICMA has applied all possible safety devices on the equipment, it must be remembered that it can be dangerous for health if not used correctly. It is therefore advised to read and comply with the safety prescriptions listed below.

Before using the equipment, all operators **MUST** have read and understood the safety prescriptions and the entire user manual.

- the machine is not suitable to be used in other sectors than in agriculture
- any use different to that specified is to be considered improper
- the manual must always be on hand, in a way to consult it when necessary. If it should be lost or damaged, request a replacement copy from SICMA
- do not climb onto, sit on or rest on the equipment for any reason, whether it is on or in the zero energy state.

2.4 OPERATOR REQUISITES

- The machine must only be used by one operator driving the tractor.
- The machine must be used exclusively by authorised, instructed and trained operators. The operator, besides having read and understood the instructions contained in this manual, must also be sufficiently prepared on the proper use of the machine and must have a driving license. The operator must contact the dealer or the manufacturer if in doubt regarding use of the machine or interpretation of this manual.
- The operator must make sure that no person or animal stops within the radius of action of the same during machine functioning. Never activate the machine near to persons standing or transiting within the radius of action of the machine.
- Do not use the machine if you are tired, ill or under the effect of alcohol, medicines or drugs.

- The correct operator position is in the tractor driving seat. From this position he must also control that there are no persons exposed in the dangerous area in the work phase.

2.5 CLOTHING AND PPE

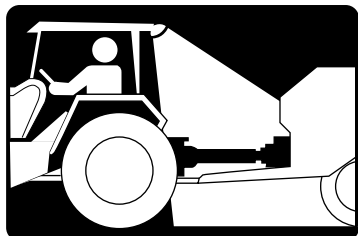
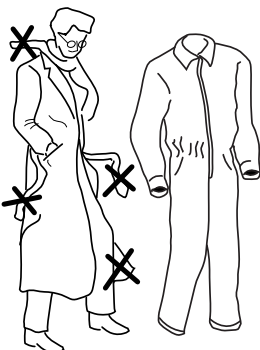
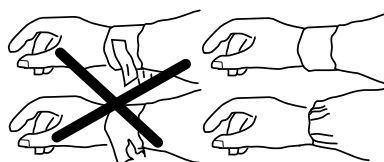

- Staff must use the safety supplies and PPE during use and maintenance of the vehicle.

The correct clothing to be worn during maintenance operations and use of the tiller is:

- gloves.
- accident-prevention shoes or boots with steel toe-cap
- glasses
- overall with elastic on the wrists, ankles and around the waist.

Moreover:

- given that the machine can generate emissions of dust during working, if the tractor does not have a closed cab, the operator must wear an anti-dust mask (especially on dry and dusty land)
- if the tractor does not have a sound-proof cab, the operator must wear hearing protections (especially on stony land)
- the operator assigned to the machine must not wear items of clothing that can cause entanglement (scarves, belts, wide sleeves, etc.).

2.6 MACHINE USE

- The machine is usually used during the day. If night-time use is exceptionally requested or use in conditions of reduced visibility, a tractor lighting system or an auxiliary lighting system must be used.
- Any arbitrary modification made on this machine lifts Sicma from any responsibility for damage or injuries that could result to operators, third parties or to objects.
- Check the machine thoroughly before each start-up.
- Check the tightness of all screws every day (consult the tightness table on page 40). If necessary, tighten them and also control the metal structures and repair them if necessary.
- Check that the retainer chains snap hooks of the Cardan shaft protection are hooked in the appropriate slot, in a way that the plastic protection remains at a standstill and does not turn with the Cardan shaft itself.
- Before getting out of the tractor and before any maintenance operation, activate the parking brake, turn the engine off, remove the ignition key from the dashboard and keep it.
- The hoes rotate rapidly when the machine is functioning: stay at a safe distance to prevent accidental contact with moving tools or with thrown objects.

2.7 SAFETY DEVICES

- Before using the machine, make sure that all safety devices are properly in place and in good conditions. If there are failures or damage to the guards, replace them immediately.
- Do not tamper with or bypass safety devices for any reason. After every cleaning and maintenance intervention, all of the safety devices must be restored and/or all protection guards closed. Check also that tools, cloths or various materials do not remain in the drive compartments.
- The signs applied to the machine supply a series of important indications: compliance with the same is for your safety.
- Make sure the safety pictograms are in good conditions. If the pictograms has deteriorated, they must be replaced with other original versions requested from the manufacturer and placed in the position indicated by the use and maintenance manual.

2.8 REASONABLY PREDICTABLE INCORRECT USE

The operator must not:

- connect the tiller to a Cardan shaft with greater or smaller power
- work in reverse gear compressing the earth with hood press
- make modifications to the equipment that could jeopardise safety
- perform makeshift repairs in order to work.

Moreover, it is prohibited to:

- couple the tiller to vehicles of unsuitable power or weight
- assemble the machine without securing the rebound tie rods of the three-point hitch of the tractor's elevator
- lift the equipment when the PTO is rotating
- tamper with hydraulic circuits
- use the machine to transport and/or to lift persons, animals or objects
- work on ground with gradient over 3°.

Sicma declines any liability for accidents deriving from the failure to comply with the prescriptions indicated below.

Given the particular stress to which the equipment is subjected and for safety reasons, if pieces are replaced, only use original spare parts.

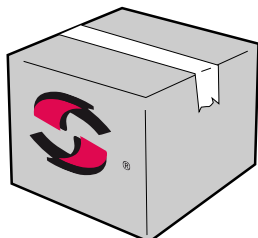

2.9 ZERO ENERGY STATE

The "zero energy state" is defined as the state in which the tiller is to be taken before performing any cleaning, lubrication and maintenance operation. Perform the following operations to take the tiller to the "zero energy state":

- position the tiller on stable, flat land with maximum gradient of 3°
- disable the PTO from the tractor
- engage the tractor hand brake
- switch the tractor off, remove the key and keep it
- get off the tractor and disconnect the Cardan shaft from the PTO tractor
- disconnect the hydraulic points
- position the outrigger in the stop position
- disconnect the 3-point hitch.

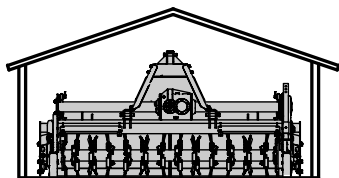

2.10 POSITION OF PICTOGRAMS ON THE MACHINE

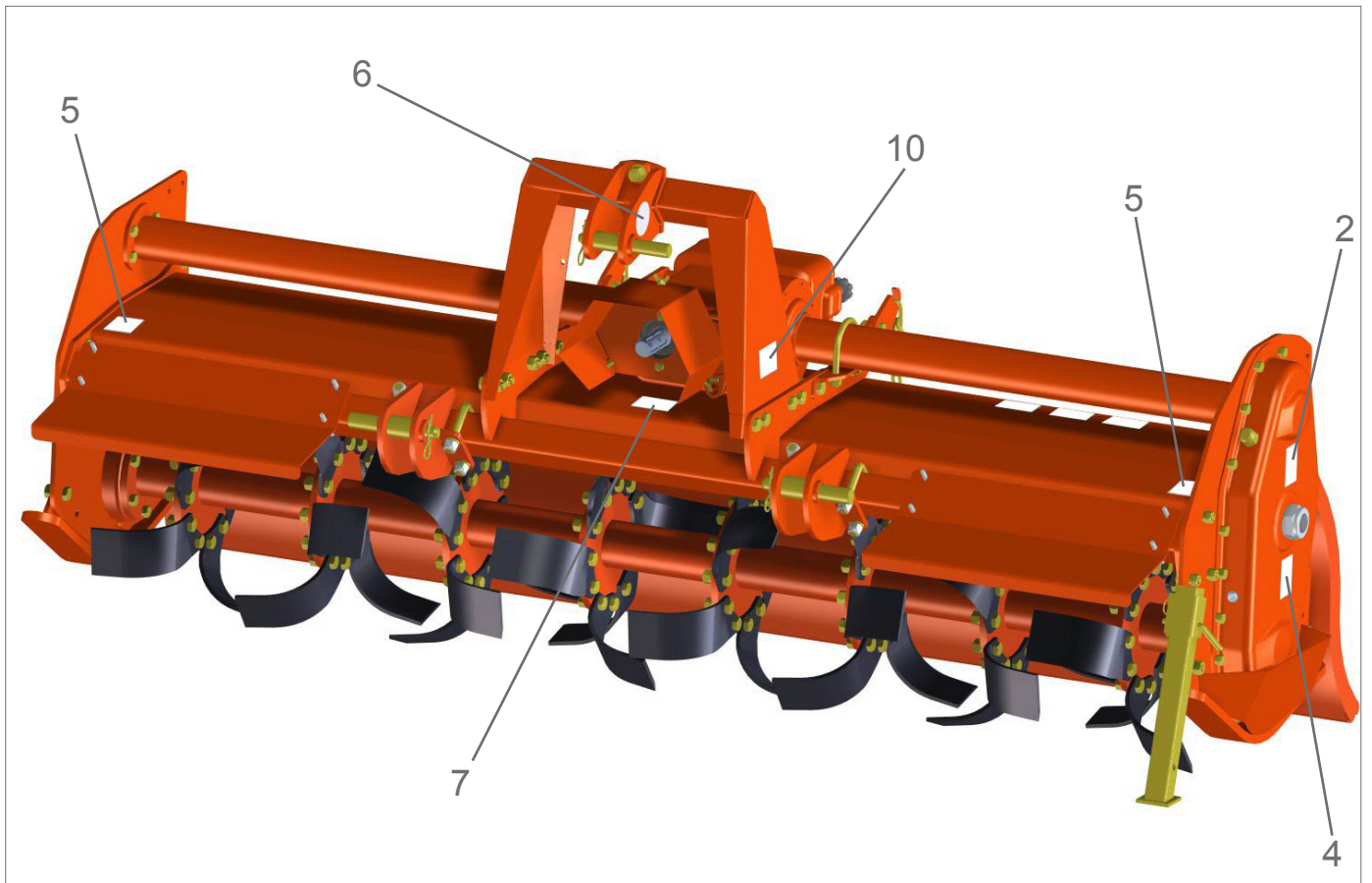
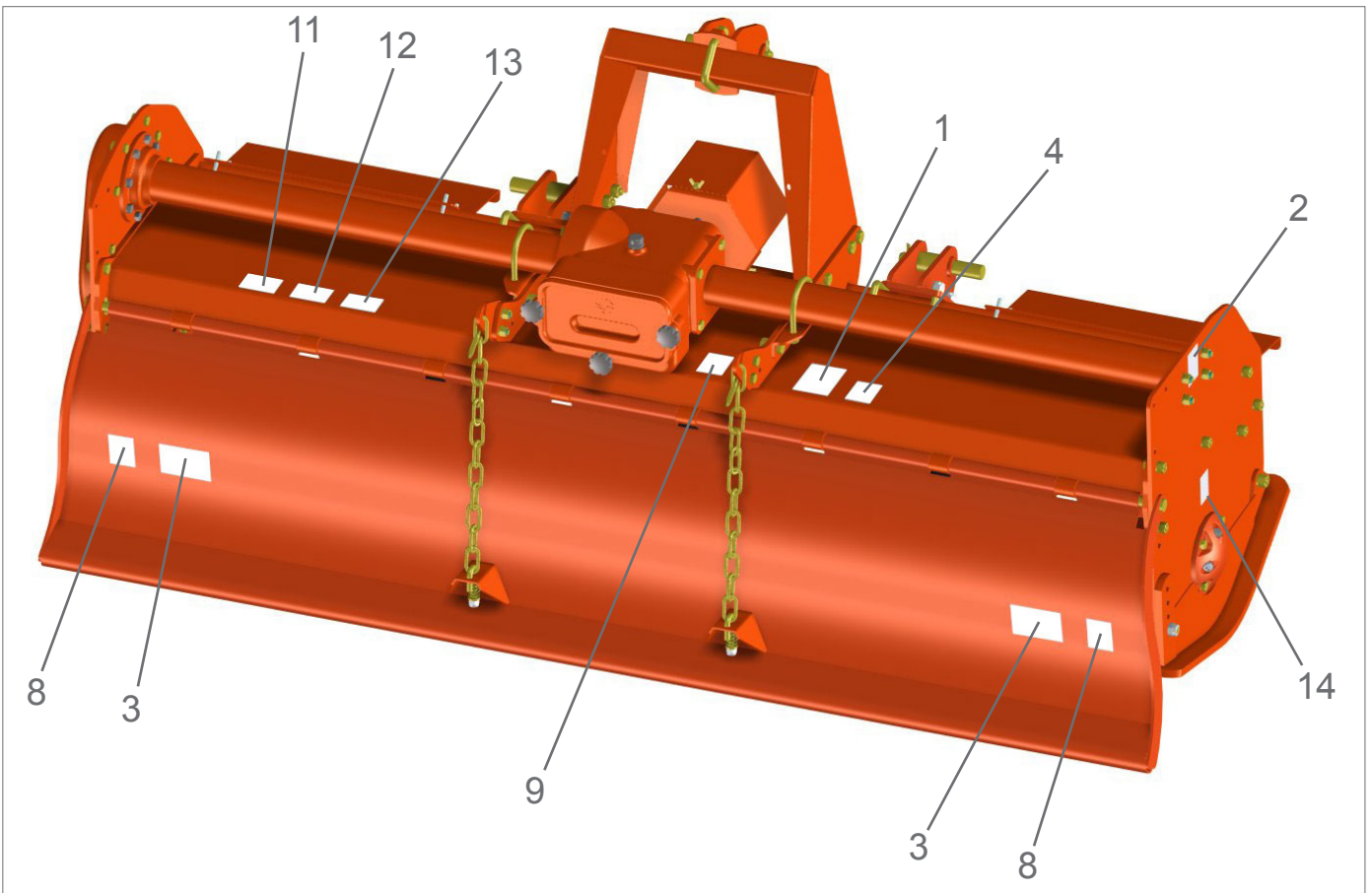

SAFETY PICTOGRAMS

1



Attention

Read all instructions and safety rules carefully before using the machine. Stop engine and remove key before starting maintenance or repairs.

2



Foot injury hazard

Keep at a safe distance from the machine.

3



Thrown objects on entire body

Keep at a safe distance from the machine.

Hand injury hazard: do not open or remove safety guards while the machine is operating.

4



Hand injury hazard

Keep safety guards in position while operating.

5



Foot injury hazard

Rotating tools: keep a safety distance from the machine.

6



Attachment point

For lifting the machine.

7



Input 540 rpm

Use of a 540 rpm power takeoff

8



Shearing hazard

Do not approach the hands.

9



Burns hazard

Do not touch hot surfaces.

IDENTIFICATION PICTOGRAMS

10



CE plate

Stating the main data with serial number and CE mark

11

PTO SPEED	15		18	
	1	15	18	185
540 rpm	16		17	
	2	16	17	208
3	17		16	
	3	17	16	235
4	18		15	
	4	18	15	266

Gear plate

Number of rotor revs depending on the various gear combinations.

12



RM Plate

Machine model

13



Width plate

Width of the machine in cm

14



OIL

Indication of lubrication oil load point



ATTENTION CRUSHING HAZARD



ATTENTION GENERAL HAZARD



ATTENTION CRUSHING AND ENTRAPMENT HAZARD



ATTENTION SLEWING AND CRUSHING HAZARD

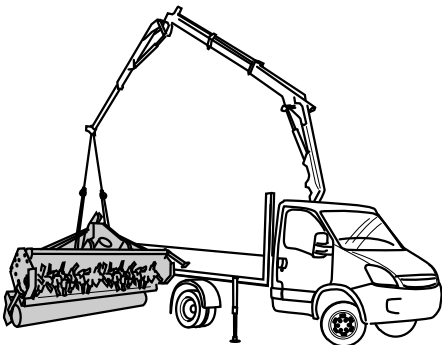

ATTENTION SLEWING AND CRUSHING HAZARD

3. UNLOADING AND UNPACKING THE TILLER

ATTENTION

Qualified staff that has read and understood the safety prescriptions must unload the tiller from the lorry and handle the equipment in the work place.

A person in charge of operations must always be present during loading and unloading. In all cases, make sure that there are no persons, animals or objects in the unload area and behave as described in this manual.

The tiller is normally transported on a lorry, sometimes without packaging, sometimes protected by heat shrinkable film and other times in wooden cases.

ATTENTION

Read and understand the "Safety prescriptions" part before starting to transport and unpack the tiller.

3.1 TILLER PROTECTED BY HEAT-SHRINKABLE FILM

NOTE

Before starting to unload the equipment from the lorry, read the entire sequence in a way to be prepared for every inconvenience in time.

Release the tiller from any fixing devices used to fasten it to the means of transport.

ATTENTION

Tiller unloading operations must be performed very slowly and the operator must make sure that there are no persons, animals and objects exposed in the unloading area.

ATTENTION

Before starting lifting

- check the good state of preservation of the ropes or chains used to lift the machine
- use ropes/chains with suitable capacity. Keep in mind that each individual rope/chain must be able to lift the weight of the tiller (see Part 3 "technical features")
- make sure that the hook bolts are fastened well
- in the event of chains with shorteners, make sure that this are also fastened correctly.

After having fastened the tiller with the ropes and/or chains, lift the equipment by a few centimetres to see if it is lifted in parallel: if it is not raised in parallel, adjust the length of the ropes/chains.

ATTENTION

Lift the tiller from the deck of the means of transport to a height of about 30 cm. unless obstacles are present, so that it does not swing. Position the tiller on the ground in proximity of the tractor.

Remove chains or ropes.

Once on the ground, unpack the equipment as described below.

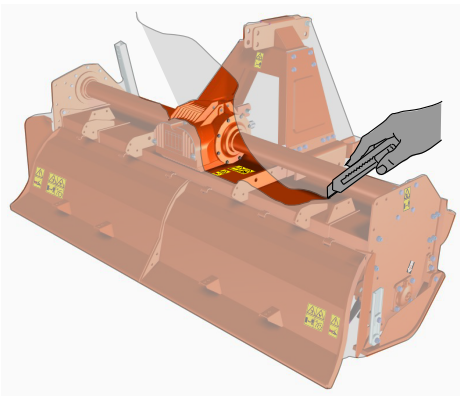

ATTENTION CUTTING HAZARD

If the tiller arrives wrapped in a protective film, cut it using a Stanley knife; pay attention not to cut the hands and not to damage the tiller itself.

To perform this operation in safety, the operator must:

- wear cut-proof gloves
- take a Stanley knife
- paying attention not to injure the hands and not damage the tiller, cut the protection.

ATTENTION POLLUTION HAZARD

Once unpacked, do not disperse the packaging in the environment but contact a specialised agency for its withdrawal. Check the transport document or packing-list supplied and, if necessary, act as described in part 1 "General Delivery Notes".

3.2 TILLER IN WOODEN CRATE

NOTE

Before starting to unload the equipment from the lorry, read the entire sequence in a way to be prepared for every inconvenience in time.

If the tiller is contained inside a wooden crate, use a fork-lift truck with suitable capacity to unload it (consult technical features table to see tiller weight) or use the lorry's lifting arm.

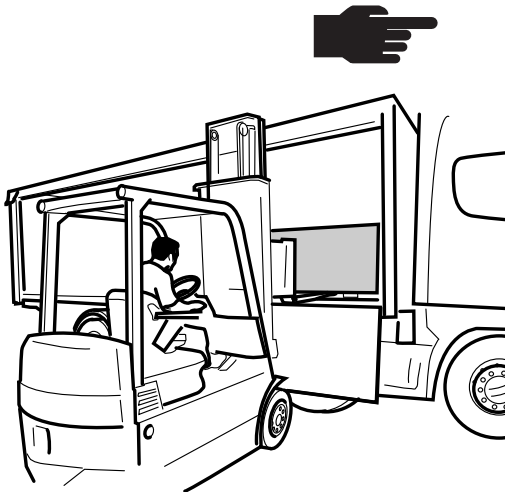

ATTENTION CRUSHING AND ENTRAPMENT HAZARD

ATTENTION

Tiller unloading operations must be performed very slowly and the operator must make sure that there are no persons, animals and objects exposed in the unloading area.

Insert the fork lift forks as indicated in the figure.

Lift the crate from the deck of the means of transport to a height of about 30 cm. unless obstacles are present.

Position the crate on the ground in proximity of the tractor.

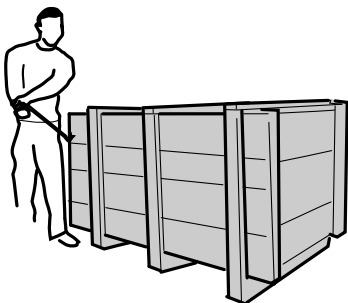

Wear gloves and using a suitable tool, remove the cover from the wooden case.

Use a fork lift truck with suitable capacity (see part 4 "Technical features"). After having fastened the tiller with the ropes and/or chains, lift the equipment by a few centimetres to see if it is lifted in parallel, otherwise adjust the length of the ropes/chains.

Use ropes/chains with suitable capacity to lift the tiller.

Lift the tiller a max. of 30 cm from the crate and position it near to the tractor.



**ATTENTION SLEWING AND
CRUSHING HAZARD**

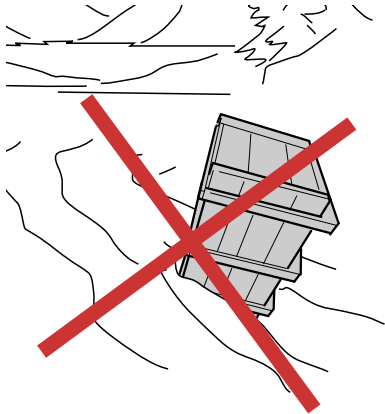

ATTENTION POLLUTION HAZARD

once unpacked, do not disperse the packaging in the environment but contact a specialised agency for its withdrawal or keep it for other transports. Check the transport document or packing-list supplied and, if necessary, act as described in chapter 1 "General Delivery Notes".



**ATTENTION OVERTURNING
HAZARD**

ATTENTION

Remember that no matter how stable the equipment, during successive transport operations, it must ALWAYS:

- be well fastened to the lorry, paying attention not to crush any hydraulic pipes
- be positioned in the centre of the lorry and not at the edges. In this way, overturning dangers are prevented, due to curves or uneven roads.

4. TECHNICAL FEATURES

Below find the table stating the technical features of the RM Tiller.

	RM 110	RM 120	RM 135	RM 150	RM 160	RM 170	RM 185	RM 210	RM 235
Overall width (A)	1268	1368	1504	1654	1754	1854	2004	2254	2504
Working width (B)	1100	1200	1336	1486	1586	1686	1836	2086	2336
Height (C)	996	996	996	996	996	996	996	996	996
Side clearance (D)	843	843	843	843	843	843	843	843	843
Work depth (E)	145	145	145	145	145	145	145	145	145
WEIGHT (standard version)	375	390	405	430	440	455	475	515	555
	827	860	893	948	970	1003	1047	1135	1224
Number of rotor revs (without gear)	221								
Number of rotor revs (with gear)	185-208-235-266								
Rotor pipe diameter	82,5	82,5	82,5	82,5	82,5	82,5	82,5	82,5	82,5
Rotor pipe thickness	10	10	10	10	10	10	10	10	10
Rotor work diameter (F)	510	510	510	510	510	510	510	510	510
Number of hoes	16	20	20	24	24	28	28	32	36
	24	30	30	36	36	42	42	48	54
Type of hoes	YES	YES	YES	YES	YES	YES	YES	YES	YES
	YES	YES	YES	YES	YES	YES	YES	YES	YES
Minimum tractor power	CV	40	40	50	50	50	60	60	60
Tractor hitch category	cat	1°-2°	1°-2°	1°-2°	1°-2°	1°-2°	1°-2°	1°-2°	1°-2°
PTO speed	rpm	540	540	540	540	540	540	540	540

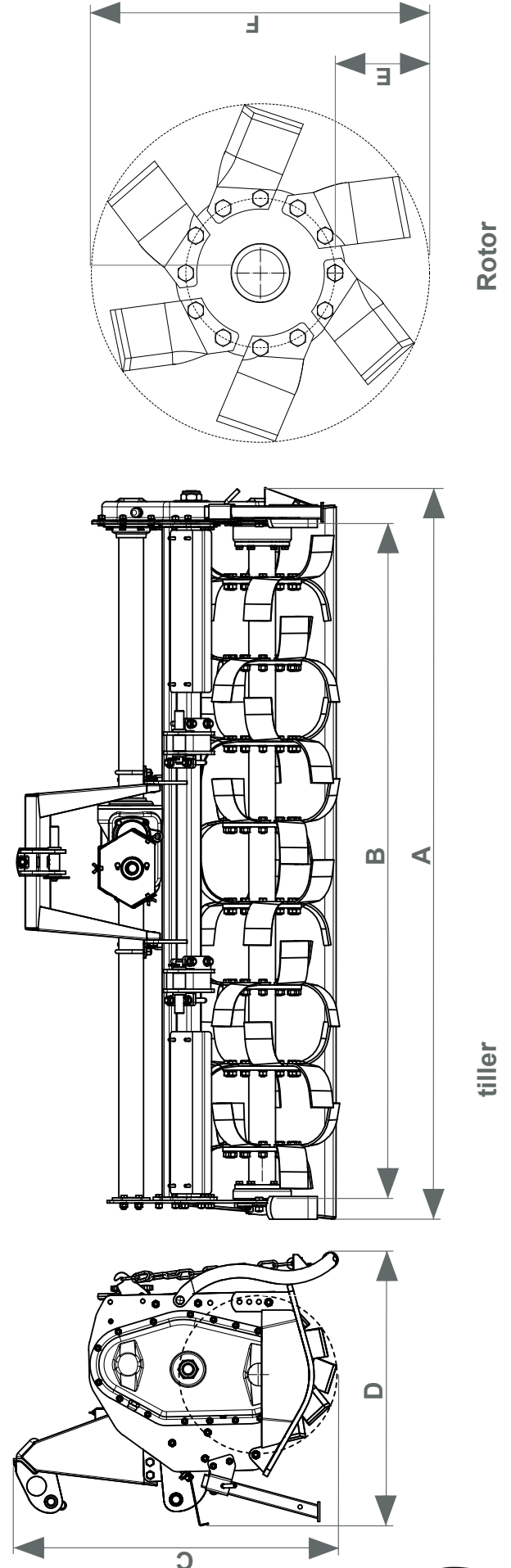



	RM 110	RM 120	RM 135	RM 150	RM 160	RM 170	RM 185	RM 210	RM 235
Weight	-	-	-	-	120	130	140	155	170
G	-	-	-	-	1700	1800	1950	2200	2450
H	-	-	-	-	880	880	880	880	880
I	-	-	-	-	750	750	750	750	750
L	-	-	-	-	484	484	484	484	484
Weight	-	-	-	-	125	135	145	160	175
G	-	-	-	-	1700	1800	1950	2200	2450
H	-	-	-	-	845	845	845	845	845
I	-	-	-	-	715	715	715	715	715
L	-	-	-	-	364	364	364	364	364
M	250	250	250	250	250	250	250	250	250
N	600	600	600	600	600	600	600	600	600
O	315	315	315	315	315	315	315	315	315
P	280	280	280	280	280	280	280	280	280
Q	495	495	495	495	495	495	495	495	495
R	345	345	345	345	345	345	345	345	345
S	615	615	615	615	615	615	615	615	615
T	360	360	360	360	360	360	360	360	360

Optional

Spiked rollers

Cage roller

Front wheels

Crusher

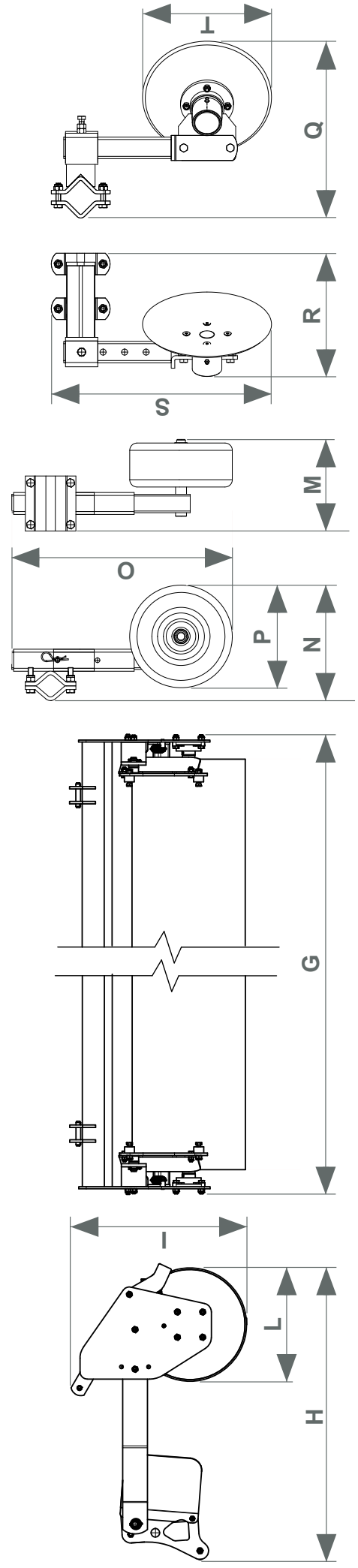

Rear roller

Front wheel

Crusher

5. START-UP



ATTENTION

Only qualified operators and which have read and understood the safety prescriptions can carry out the operations described below. Moreover, they must check that there are no persons, animals and objects exposed in the area where the connection is made to the tractor.

The operator and any aids must have PPE available and wear them as required.

The tiller can only be moved if hitched to the tractor. To do this, follow the instructions given below step-by-step

The operations that follow must be performed according to the order indicated.

- CARDAN SHAFT CONNECTION
- 3-POINT HITCH CONNECTION TO THE TRACTOR



5.1 CARDAN SHAFT CONNECTION

Before assembling the Cardan shaft, the operator must:

- read the Cardan shaft and tractor manual.
- check that the number of revs. and the direction of rotation of the tractor PTO correspond to those of the tiller. If the direction of rotation of the tiller does not correspond to that of the tractor, contact the dealer or an authorised workshop.
- check that the Cardan shaft minimum and maximum lengths are those required by tiller-tractor coupling. Remember that when at maximum extension, the pipes must overlap at least 1/3 of the length of the internal pipe. Moreover, in the maximum closure position of the pipes, the minimum play allowed of the plastic protections must be at least 2 cm. in order to prevent damage to the protections and the reducer. If this is not the case, it must be shortened suitably butting cutting that necessary. Consult the Cardan shaft use and maintenance manual or contact the authorised dealer.

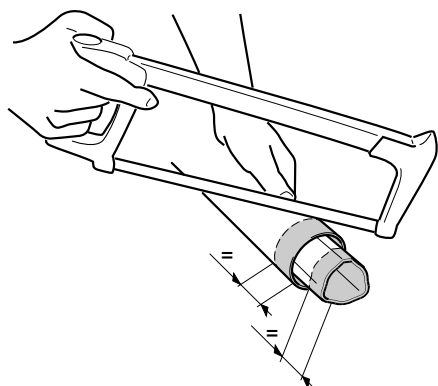
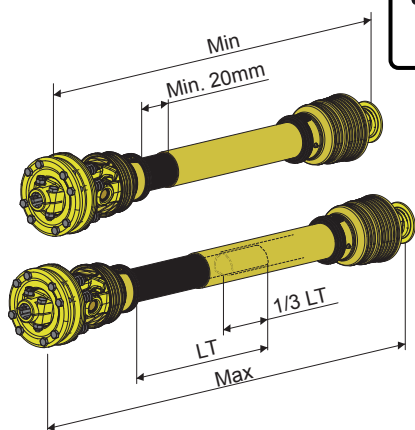

To connect the Cardan shaft, the operator must:

Slowly approach the tractor to the tiller, position in a way that the lifting

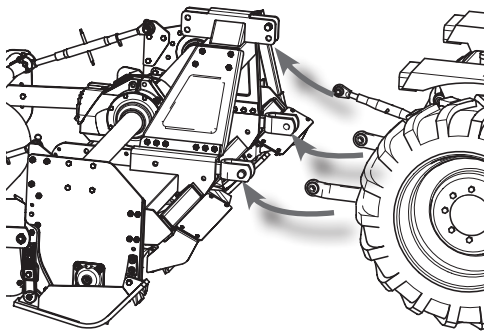

device arms of the tractor are aligned with the two lateral pins of the tiller. Once in position, engage the hand brake, switch the engine off, remove the key and keep it and climb down from the tractor. Check that the Cardan shaft protection is integral as per image at the side. If this is not the case, act accordingly consulting the relative user manual.

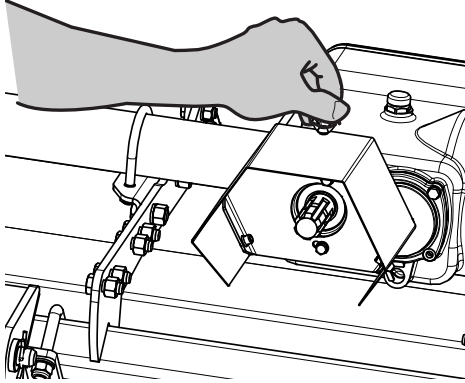

Loosen the 3 screws that fix the tiller PTO protection and remove it.

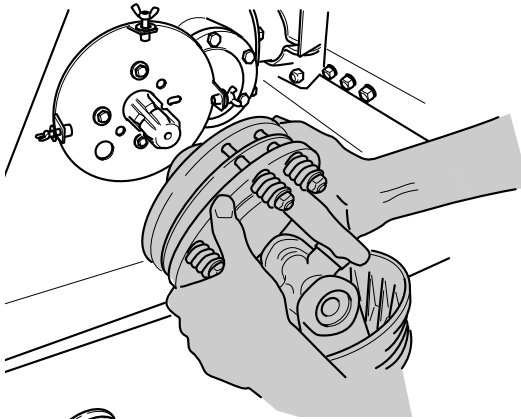

Direct the Cardan correctly, so that the clutch is positioned from the side of the equipment. In the event of joint without clutch, to position the Cardan correctly, refer to the figure of the tractor embossed on the external protection pipe.

Insert the Cardan shaft hub on the tiller PTO. Once it is ensured that the clutch has entered completely, tighten the double bolt with two 21 mm wrenches.

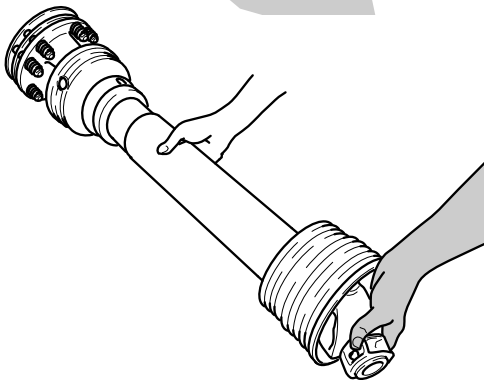

Re-position the protection on the tiller PTO
Tighten the 3 fastening screws that were loosened previously.
Insert the Cardan shaft onto the tractor PTO, holding the safety pin pressed. Release the pin and retract with the Cardan until the pin itself engages in the relevant seat with an audible "click".

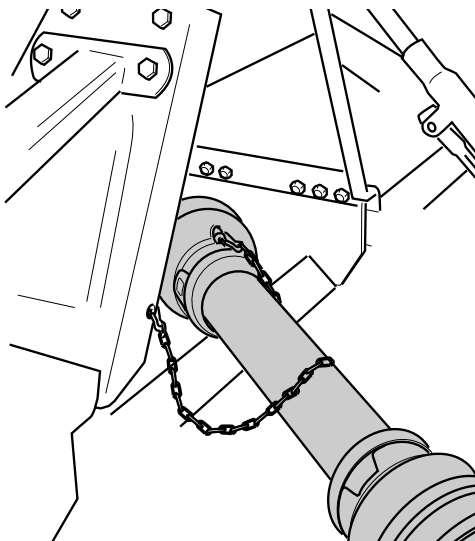

Attach the snap hook of the Cardan shaft protection retainer chain in the relevant slot on the upper third point sheet steel. Carry out the same operation on the tractor PTO.



5.2 3-POINT HITCH CONNECTION



INPUT 540
540 rpm

The machine must be connected to the tractor with a 540 rpm driven power take-off, having suitable weight and power and with standard 1st or 2nd category hitch.

Proceed as follows to hitch the machine to the tractor:

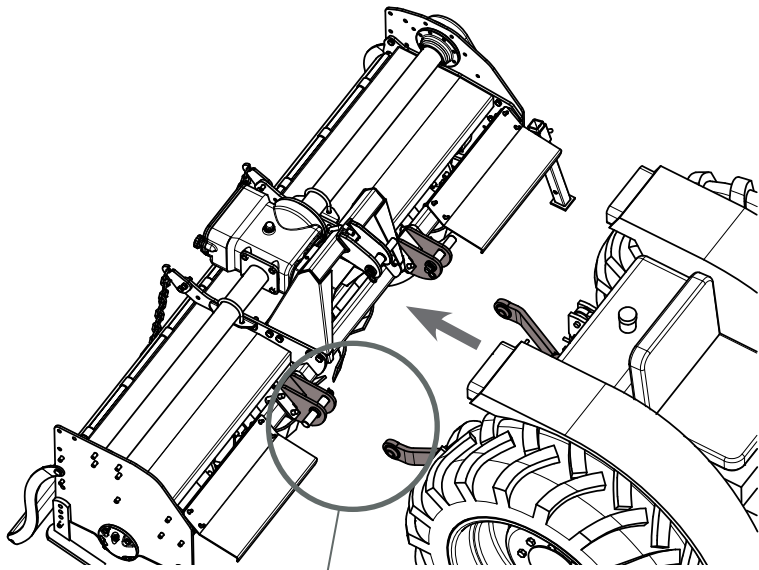

- remove the split pin A of pin B
- slide pin B out
- climb onto the tractor and switch the engine on
- release the hand brake
- reverse slowly until the tractor lifting device arm joint C combines with the lower third point of the tiller D
- switch the engine off, engage the hand brake, remove the key and keep it and climb down from the tractor
- Insert the pin into the hole of the lower third point of the tiller and into the hole of the tractor arm joint.
- re-insert the split pin.

Proceed in the same way with the other lower hitch.

- Block the rebound tie-rods of the tractor lifting arms to prevent the machine oscillating laterally, compromising the transversal stability of the complex.

To connect the upper third point, the operator must:

- remove the split pin E of the pin F of the upper third point of the tiller.
- slide pin F out
- release the tie-rod G of the tractor upper third point and insert it into the upper third point H of the tiller
- re-insert the pin F and the split pin E into the tiller upper third point and into the tractor tie-rod joint
- lift the tiller until the machine and tractor power points are taken to the same height and register the tensioner, taking the machine to a horizontal position
- adjust the length of the tie-rod so that the upper part of the frame is parallel to the ground.

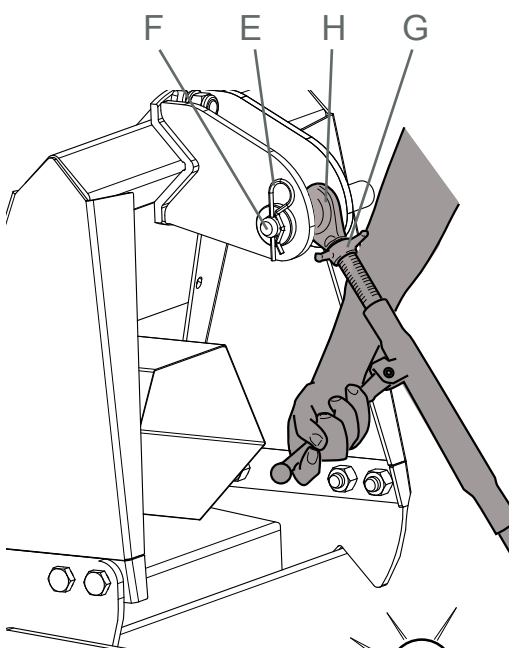
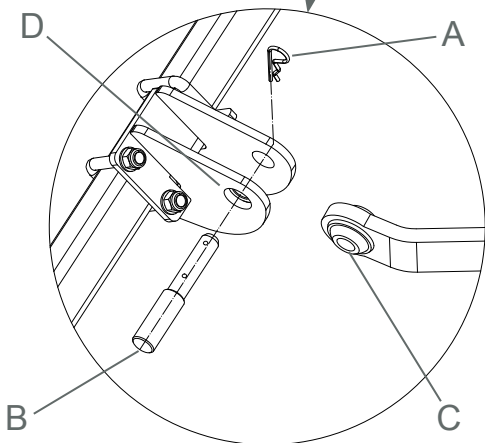

It is always good practice to make sure that the tiller PTO axis is parallel to the ground thus reducing the stress to a minimum on the power take-off and extending the working life of the tiller.





**ATTENTION OVERTURNING
HAZARD**

CHECK THE STABILITY OF THE TRACTOR-TILLER COMPLEX.

Tiller weight changes the stability of the tractor-tiller complex, influencing steering and braking capability. Therefore proceed at a moderate speed. In particular, remember that the front axis must always be encumbered by a weight equal to at least 20% of the total weight of the tractor-tiller complex. Check the lifting capability and tractor stability using the following formula and, if necessary, apply ballasts on the front.

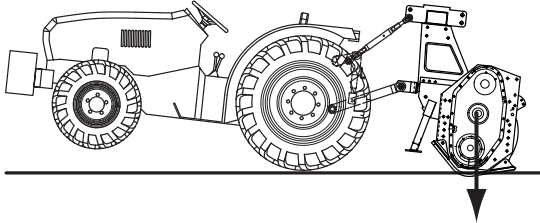

$$M \times (S1+S2) \leq 0.2 T \times i + Z \times (d+i)$$

$$M \leq 0.3T$$

i = wheel base

d = distance from the front axis from the ballasts

S1 = distance between centre of the rear axle and centre of the lower hitch points

S2 = distance between the centre of the lower hitch points and barycentre of the tiller

T = weight of the tractor + 75Kg (operator)

Z = weight of the ballast

M = weight of the machine

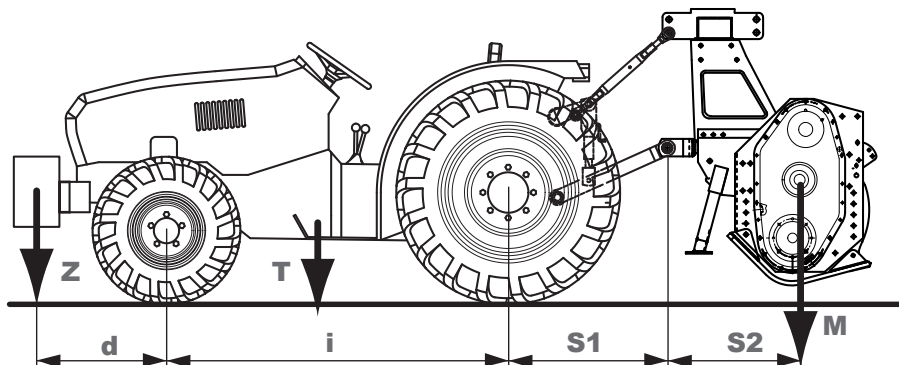

5.3 ROAD TRANSPORT

Articles 61 and 104 of the Highway Code of the Italian State prescribe that the maximum width of vehicles on roads is 2.55 metres. As a consequence, all measurements of the RM available are authorised for road transport, in compliance with the other prescriptions of the Highway Code.

If the Country of reference is not Italy, follow the Highway Code Standards of the country of use.

6. ADJUSTMENTS

6.1 ROTATION SPEED CHANGE

At time of purchase it is possible to choose among two configurations of the RM machine: with and without speed gear.

In the event the tiller has the speed gear, to modify the rotation speed of the rotor, the positions relative to the straight gears contained in the gear box must be exchanged.

Before making the replacement, wait for the gear box to have cooled down and wear the relevant PPE, in particular gloves as there is a hands burning hazard present.



**ATTENTION BURNS
HAZARD**



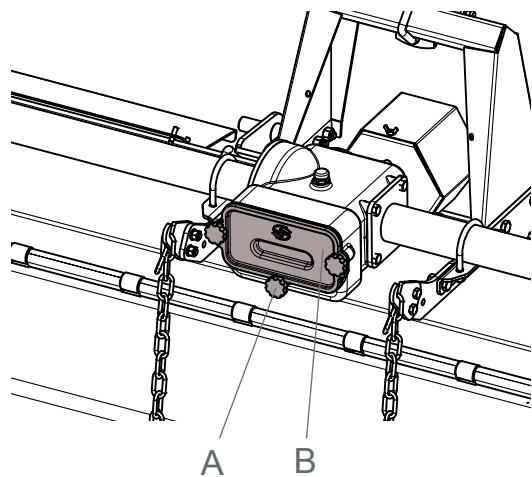

To regulate or replace the gears torque, first remove the oil from the gear unit boxes as indicated in point 8.1.

Decide at what tractor rotation speed to work at, consulting the following table.

pto rpm	Z1	Z2	N. revs. rotor
540	15	18	185
	16	17	208
	17	16	235
	18	15	266

(standard configuration)

Unscrew the 3 screws "A" of the gears support lid "B". Inside there are 2 pins that support 2 reserve gears "C" and "D" (that do not work and are used to guarantee the other speeds). The gears are flush fitted onto two drive shafts. To change the speed, invert the 2 gears that work or replace the 2 reserve gears. Re-position the gears support lid and tighten the 3 screws again.

6.2 CLUTCH ADJUSTMENT

The joint and the clutch associated to the machine are dimensioned to transmit suitable power to the machine itself and the calibration value is already set in the factory, therefore it is not recommended to modify the clutch calibration in order to prevent damage to the machine or the Cardan joint. SICMA does not respond to machine damage deriving from incorrect modification of the clutch calibration.

However, the regulation can be made if it is realised that the clutch is engaged too frequently, even though working on easy land, i.e. soft and not compact: this means that clutch calibration is too low.

The clutch associated to the Cardan Shaft is a FD2 EUROCARDAN, with standard calibration of 900Nm. If the clutch calibration must be increased, screw the springs hold down nut by 1/4 of a turn (using two 17 mm wrenches): there will be a transmissible torque increase of about 140 Nm. Loosen the nuts if calibration is to be decreased.

In the event the clutch is not to be used for a long period, it is recommended to loosen the nuts that compress the springs in order to prevent that the disks "stick" to one another (seizure). Upon re-use of the safety device, for correct calibration carry out the following operations:

- manually tighten the nuts until they rest against the springs
- use two 17 mm wrench to loosen the nuts by 1.5 turns each.



Attention: make sure that the height of all compressed springs is the same in order to prevent clutch malfunctioning.

Warning: The clutch springs do not have to be close-wound because the machine would no longer be protected against any overloads.

6.3 WORKING HEIGHT ADJUSTMENT

The work height can be modified by operating on the position of the skids or any rear roller (optional).

To modify the position of the skids, after having lifted the tiller, operate as described:



Attention Hand cutting and shearing hazard

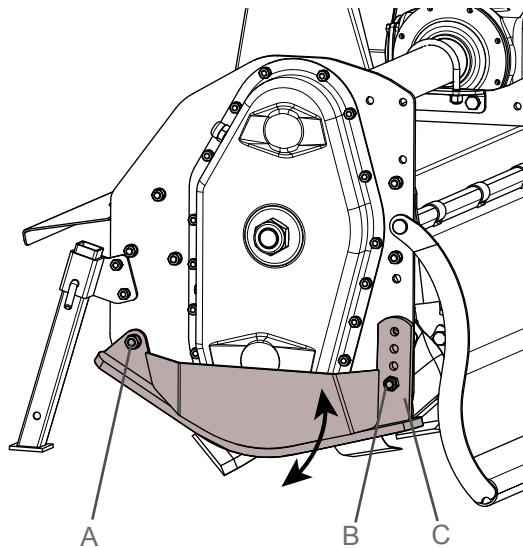

Loosen bolt A using 21 mm wrench and followed by bolt B and until the toothed plate D can run. Turn the skid until the desired position is reached. Perform the same operation on the opposite skid, making sure that both skids are adjusted to the same height.

Whenever your machine has a roller, the skids are not adjustable and the tilling depth also depends on its position.

The function of the rollers is to flatten, level or compact the land after it has been tilled in order to prevent non-uniformity (see page 13).

To adjust the roller, turn the relevant lever as per figure.

To increase the tilling depth, the height of the rear roller must be increased with respect to the hoes-support rotor, vice versa to decrease it.

Make sure that the roller has been positioned at the same height on both sides.

Finally check that the tiller is parallel to the ground and, if necessary, regulate its planarity by operating on the tie-rod lever of the upper 3 points hitch.

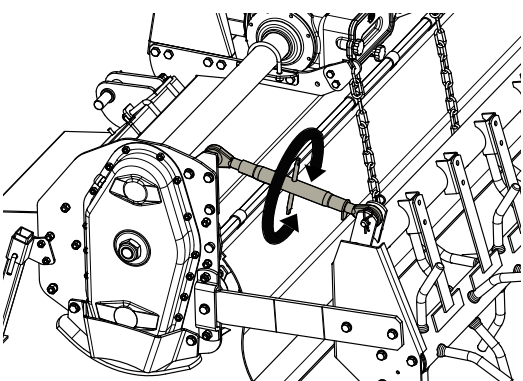

6.4 COVERS ADJUSTMENT

If the tiller has rear cover with chain, the inclination can be adjusted by simply shortening or lengthening the tract of taught chain.

When performing the following operations, pay attention not to put the hands between the two covers (RM 235). During regulation of the rear lid, do not lift/lower it from the sides but only from the lower edge.

If the tiller has cover with bonnet presses, the inclination can be adjusted to obtain more or less land compacting.

If the cover is to be opened further:

- remove the upper split pin of the bonnet press rod and position it in the upper hole
- lift the cover making the springs run manually upwards along the rod,
- remove the lower split pin of the bonnet press rod and re-insert it in the upper hole
- Perform the same procedure for the other semi-cover
- If the cover is to be closed further, proceed in the opposite direction.



Attention Hand cutting and shearing hazard

6.5 MACHINING

Once all controls and regulations have been performed, with the tractor connected to the tiller (via 3 point hitch, but with Cardan shaft disconnected), switch the tractor on and go to the work area, remembering to keep the hoes lifted so that they do not touch the ground (at least 20 cm).

To work, the tiller must be connected to a tractor. It is from the tractor itself that all tiller controls are managed.

The operator must refer to the tractor manual in order to use the tiller.

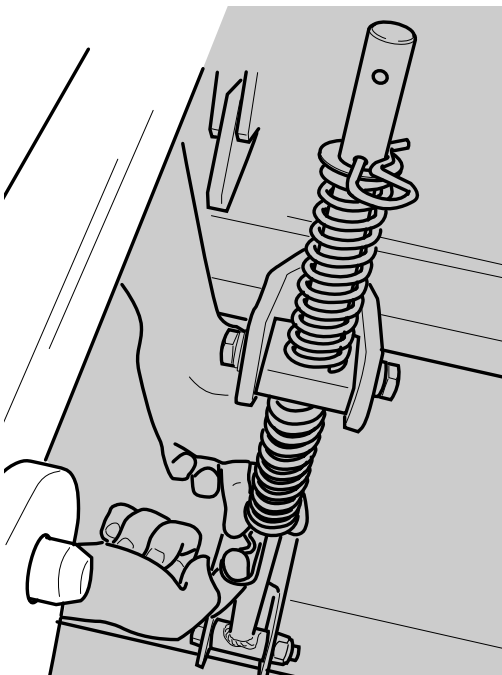

WARNING

Before starting work, make sure that no people or animals are within the radius of action of the machine.

Make sure all equipment protections are present and efficient.

The machine must only be used by one operator positioned inside the tractor driving cab.

Make sure there are no restrictions that prevent movements. If there are restrictions, release the equipment from any fastening device.

PREVENTIVE MAINTENANCE

Before using the machine for the first time, or after a long period of inactivity, carry out the following:

- check that the machine is not damaged
- check the mechanical parts, are in good conditions and not rusted
- check the state of wear of the tools
- grease all mobile parts precisely
- check that there is no oil leakage coming from fittings or piping
- check that all safety guards are properly positioned
- visually check the machine before all use. Tighten any loose bolts according to the coupling torque tables given on page 40
- check the oil level in the gear box unit, in the lateral drive sump and in the external side rotor support and top-up to the correct level if necessary (see chap. 8 "Routine maintenance")
- grease the rear roller supports (optional).

Use the following lubricants for lubrication:

- oil: **AGIP-ENI BLASIA 150**
- grease: **AGIP GREASE MU EP 2**



NOTE

Before working with the equipment, read the entire sequence in a way to be prepared for every inconvenience in time.

It is good practice to start the equipment in reduced normal conditions especially in cold environments, to allow the system to run-in and to prevent equipment malfunctioning.

On arrival at the work place, the operator must:

- engage the hand brake
- switch the engine off
- remove the ignition key and keep it
- get off the tractor
- check that there are no persons, animals and objects in the exposed area
- connect the Cardan shaft to the tractor PTO as described in point 5.1.

Once connected to the Cardan shaft, the operator must:

- turn the tractor engine on
- release the hand brake
- work at a maximum speed of 6 km/h reducing it to about 2 km/h if the land is difficult to work (hard, stony, etc.).

Keep the tractor engine running at a rev speed that assures the machine the needed power for its use.

Run a short way with the tiller working and check the quality of the work carried out. If it does not satisfy you, repeat and review the machine adjustment operations.



Attention Feet cutting and shearing hazard



Attention Thrown objects hazard



Never place hands and feet near to the tools-holder rotor when it is rotating (or when in zero energy state).

During functioning, the machine can project material from the rear part: make sure that animals and persons are at least 5 metres from the machine.

In the operations involving change of direction, turning and going in reverse, disengage the power take-off and lift the tiller slightly from the ground, in order to avoid structure damage.

When the job has been finished, the operator must:

- engage the hand brake
- switch the engine off
- remove the ignition key and keep it
- get off the tractor
- disconnect the Cardan shaft from the tractor PTO and place it in the relevant support hook
- Climb onto the tractor and release the hand brake
- Switch the tractor on
- Paying attention during movement that there are no exposed persons, animals or objects, take the tiller into the deposit.

Once having reached the deposit, the operator must:

- engage the hand brake
- switch the engine off
- remove the ignition key and keep it
- clean the tiller (see chap.9 "CLEANING")
- check that there are no oil leaks, stop any leaks present (Ground pollution hazard)
- check and if necessary, replace any worn parts (see chap. 8 "Maintenance").



NOTE

If the equipment stops during working, consult par.12.2 "Troubleshooting".

7. STOPS

ATTENTION GENERAL HAZARD

Only qualified operators and which have read and understood the safety prescriptions (Chap. 2) can carry out the operations described below. Moreover, they must check that there are no persons, animals and objects exposed in the dangerous area.

The equipment must be stopped in the following ways:

- Temporary stop
- Stop at the end of the day
- Stop for long periods
- Emergency stop

Below find the description of how to behave in each case.

TEMPORARY STOP

To stop the tiller temporarily, just deactivate the rotation of the tractor PTO by activating the relevant control in the tractor control panel.

If the operator must get off the tractor, he must:

- engage the hand brake
- switch the engine off
- remove the ignition key and keep it
- get off the tractor.

STOP AT THE END OF THE DAY

- engage the hand brake
- switch the engine off
- remove the ignition key and keep it
- get off the tractor
- disconnect the Cardan shaft from the PTO tractor
- clean the tiller (see chap.9 "CLEANING")
- check that there are no oil leaks, stop any leaks present (Ground pollution hazard)
- check and if necessary, replace any worn parts (see chap. 8 "Routine maintenance").

STOP FOR LONG PERIODS

When the machine is parked for long periods of time:

- activate the tractor parking brake
- lower the machine resting feet
- place the tiller on the ground
- turn the tractor engine off
- remove the ignition key from the control panel and keep it
- descend from the driver position
- detach the Cardan shaft
- rest the Cardan shaft on the relevant support
- pull out the split pin and the gudgeon and detach the tie rod (upper third point)
- fix the tie-rod to the appropriate support on the tractor
- pull out the slip pins and the connecting gudgeons and then the tractor's rear hydraulic lift arms from the tiller's hitch points
- get back onto the tractor
- start the tractor and move away carefully
- clean the tiller (see chap.9 "CLEANING")
- lubricate all of the tiller with an anti-rust product.

The machine must be parked on flat land and within a protected area, so as to prevent unauthorised staff from approaching.

EMERGENCY STOP

To stop the tiller in emergency conditions, just deactivate the rotation of the tractor PTO by activating the relevant control in the tractor control panel. At this point, engage the hand brake, switch the engine off, remove the key and keep it.

Identify the cause of the emergency stop and, if necessary, consult par. 12.2 "Troubleshooting".

Decide:

- if necessary, take the equipment to the zero energy state
- if after-sales assistance must be requested
- if it can be repaired.

Once the cause of the emergency stop has been eliminated, the equipment has been re-started.



8. ROUTINE MAINTENANCE



**ATTENTION GENERAL
HAZARD**

ATTENTION

Only qualified operators and which have read and understood the safety prescriptions (Chap. 2) can carry out the operations described below. Moreover, they must check that there are no persons, animals and objects exposed in the dangerous area.

The operator must know and scrupulously follow the indications and must have put the machine out of service.

The periodic controls and the maintenance operations described in this chapter must be performed in the times and ways established and are the operator's responsibility.

Failure to comply with Standards and maintenance times jeopardises the good functioning of the machine and its duration and as a consequence the validity of the warranty.

For any other maintenance, consult par. 12.2 "Troubleshooting" or contact the Manufacturer or its after-sales centres.

Considering the complexity of the equipment, repairs, modifications, extraordinary maintenance different to those mentioned below **MUST NOT** be performed without having consulted the Manufacturer or its after-sales centres. Depending on the case, these will give authorisation to proceed along with all instructions necessary or they will recommend the intervention of one of its own technicians.

These precautions are due to the fact that, incorrect or unsuitable operations can lead to abnormal functioning conditions, causing damage to the equipment and risks to staff.



**ATTENTION
OVERTURNING, CRUSHING
HAZARD**

ATTENTION

Before performing maintenance, read all of this part in a way to be prepared for every inconvenience in time.

ATTENTION

Ensure stability of the equipment (tractor and tiller) before performing any maintenance intervention (the maximum gradient limit of the ground is 3°).

Before carrying out any maintenance operation, the operator must take the tiller to the zero energy state (See par. 2.10)

The maintenance technician and any aids must have PPE available and wear them as required.

Do not perform repairs of which you have no knowledge. Always follow the instructions. If they are missing, contact the supplier or expert personnel.

Do not use lifting points different from those prescribed.

Make sure that the chosen lifting device is suitable to carry out operations in compliance with safety Standards.

Do not leave the tractor engine running in closed places if they do not have a ventilation system suitable to remove toxic gas exhaust concentrated in the air.

Avoid prolonged and repeated skin contact with lubricants as they could harm skin and cause other syndromes.

Do not ingest fuels/lubricants/fluids. In the event of accidental contact the eyes, wash them well with water.

Do not weld in closed places or in those which are not appropriately ventilated.



**ATTENTION GENERAL
HAZARD**



Do not weld on painted surfaces, to prevent the formation of toxic vapours. Remove paint with suitable products and then wash the surfaces and let them dry.

SICMA INFORMS THAT ANY MODIFICATION OR TAMPERING OF THE TILLER OR ANY OPERATION PERFORMED IN DISAGREEMENT WITH THAT WRITTEN IN THIS MANUAL, ESPECIALLY FAILURE TO COMPLY WITH THE SAFETY PROVISIONS, AS WELL AS MAKING THE WARRANTY NULL AND VOID, RELIEVES SICMA FROM ANY LIABILITY FOR DAMAGE TO OBJECTS AND INJURY TO PERSONS.



**ATTENTION BURNS
HAZARD**



**ATTENTION POLLUTION
HAZARD OF THE LAND AND
WATER TABLES**

8.1 CONTROL AND REPLACEMENT OF THE OIL IN THE GEARBOX UNIT

ATTENTION

Wait for the gearbox to have cooled down before touching it.

ATTENTION

The operator must pay attention to oil leaks and perform relative maintenance immediately. Moreover, oil must not be poured onto the ground when topping-up or replacing the oil.

The oil level control in the gear unit box must be performed verifying the mark left by the oil itself on the load cap dip-stick A, which must be between the two reference signs (minimum and maximum).

The control must be performed every 50 working hours.

If top-up is necessary, proceed as follows:

- use a 27 mm wrench to remove the oil load cap A
- top-up the AGIP-ENI BLASIA 150 oil to the level on the dip-stick
- re-insert the load cap and tighten it with force using the 27 mm wrench operated previously.

The oil on the gearbox unit must be replaced as follows:

- the first time after the first 50 hours of work
- every 500 hours of work.

To change the oil:

- position a container under the oil drain
- loosen the oil drain cap B (lower part of the sump) and allow the oil to flow out completely
- dispose of the drained oil in appropriate containers for waste oils
- screw the previously unscrewed oil drain cap B
- loosen the oil load cap A (upper part of the sump)
- use a small funnel to top-up with AGIP-ENI BLASIA 150 oil until the level is reached
- top-up and tighten the oil load cap A.

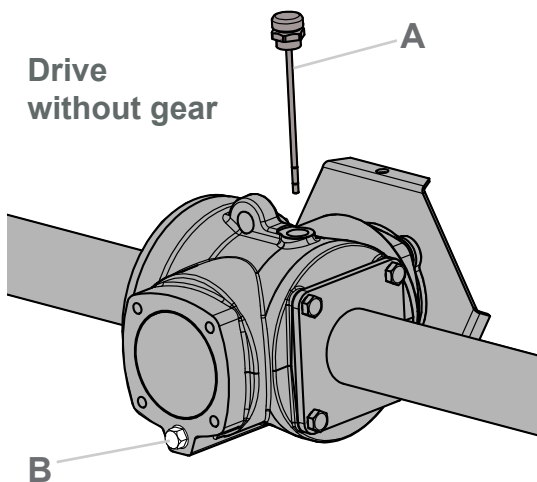
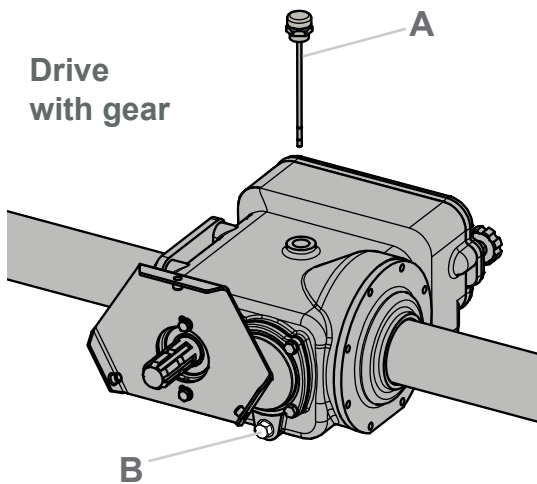

8.2 CONTROL AND REPLACEMENT OF THE OIL IN THE LATERAL DRIVE SUMP

The oil level in the lateral drive sump must be controlled every 50 working hours, verifying that it is visible inside the inspection window of the oil level lateral cap C.

If top-up is necessary, proceed as follows:

- use a 24 mm wrench to remove the oil load cap D
- top-up the AGIP-ENI BLASIA 150 oil until it is visible inside the cap C inspection window
- screw the load cap D again by tightening it using a 24 mm wrench.

The oil in the lateral drive sump must be replaced as follows every 500 hours of work

8.3 CONTROL AND REPLACEMENT OF THE OIL IN THE EXTERNAL ROTOR LATERAL SUPPORT

The oil level in the rotor lateral support must be controlled every 50 working hours, verifying that the oil present is visible inside the inspection window of the cap E situated on the support itself.

If top-up is necessary, proceed as follows:

- use a 15mm wrench to loosen the oil load cap F
- top-up the AGIP-ENI BLASIA 150 oil until it is clearly visible inside the cap E inspection window
- tighten the load cap by tightening appropriately using the 15mm wrench.

The oil rotor lateral support must be replaced as follows:

- the first time after the first 50 hours of work.
- every 500 hours of work.

To change the oil:

- remove the lateral skid in correspondence with the lateral support by loosening bolts H and I
- position a container under the support
- use a 17mm wrench to loosen the four bolts G that fasten the lateral support and allow the oil to flow between the support and plate
- dispose of the drained oil in appropriate containers for waste oils
- use a 17mm wrench to tighten the four previously loosened bolts
- top-up the AGIP-ENI BLASIA 150 oil until it is visible inside the cap E inspection window
- tighten the load cap F appropriately using the 17 mm wrench.

8.4 GREASING

Greasing operations are performed using a relevant manual greasing pump, as shown in the figure.

GREASING REAR ROLLER SUPPORTS

The rear roller supports greasing points must be greased every 8 working hours using AGIP GREASE MU EP 2 grease.

8.5 REPLACING HOES/BLADES

Every 50 hours of work, visually check the wear of the hoes/blades. The hoes/blades must be replaced when the ground has unworked rows due to lack of covering between the hoes and/or the hoes are visually worn. Wear depends on the hours worked, the type of land etc....

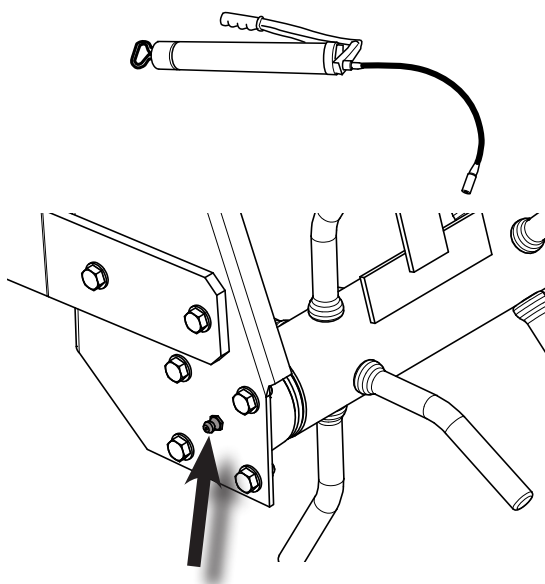
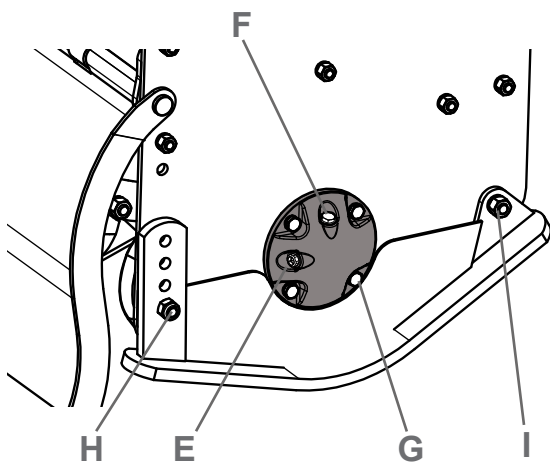
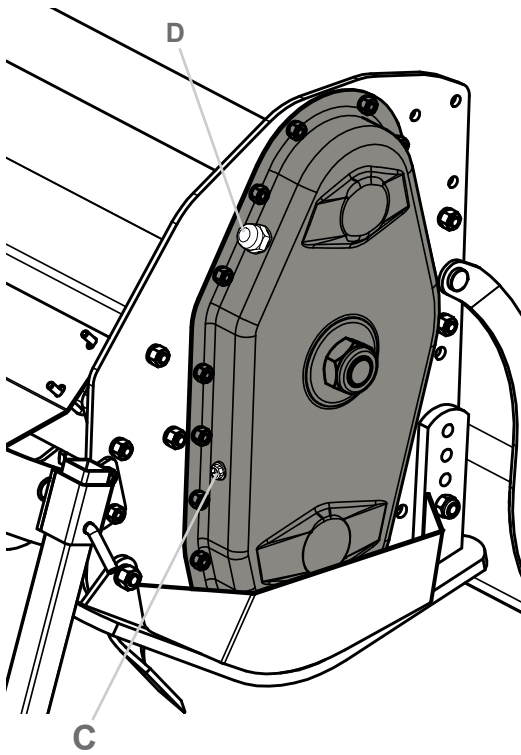

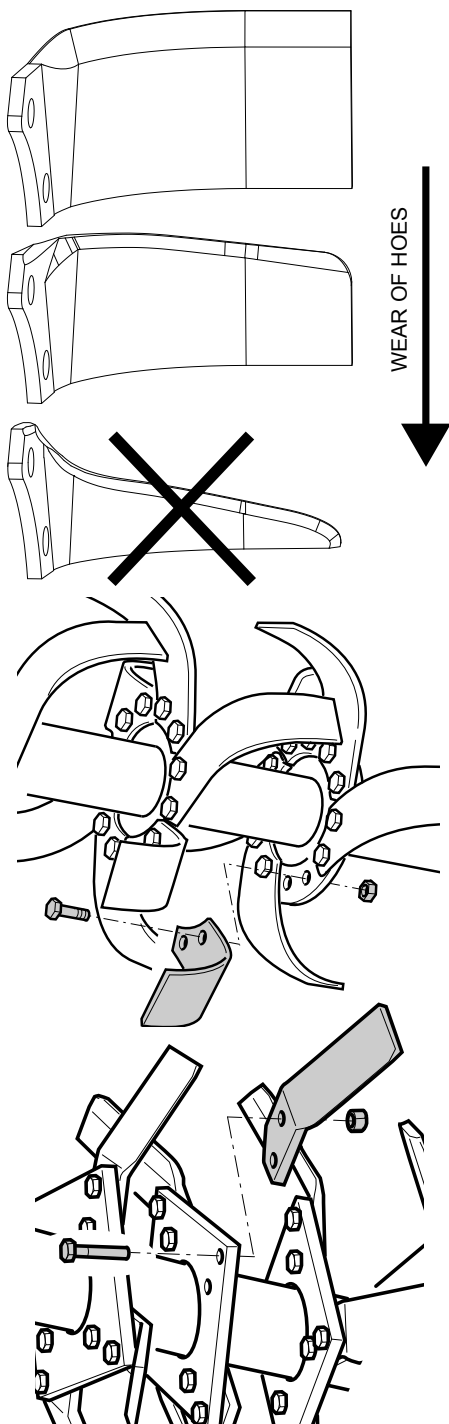

Use of non-original tools can cause anomalous vibrations for the machine.

When replacing tools with the tiller lifted, do not trust the capacity of the tractor's hydraulic lift: insert mechanical posts or support tripods between the machine and the ground in order to avoid unwanted and dangerous descents of the machine.

To perform the following operations, the operator must wear gloves and glasses and must NEVER be positioned UNDER the rotor.

Operate as follows to replace the hoes/blades:

If the tiller does not have a roller:

- hitch the tiller to the tractor without Cardan shaft
- lift the tiller max. 10 cm from the ground
- strut the tiller with supports of suitable size
- use two 24 mm wrenches and, on the basis of the hoe/blade to be replaced, loosen the relative bolts
- remove one worn hoe/blade at a time and re-mount the new one, paying attention to re-mount it exactly in the original position, tightening the bolts correctly and as shown in the table on page 40
- proceed in the same way for the other hoes/blades.

If the tiller has a roller:

- obtain two safety stands suitable to support the weight of the tiller and its optionals
- with the aid of the tractor, lift the tiller and rest it on the stands
- be positioned in front of the machine
- use two 24 mm wrenches and, on the basis of the hoe/blade to be replaced, loosen the relative bolts
- remove one worn hoe/blade at a time and re-mount the new one, paying attention to re-mount it exactly in the original position, tightening the bolts correctly and as shown in the table on page 40
- proceed in the same way for the other hoes/blades.

8.6 CARDAN SHAFT

For lubrication and for maintenance interventions, behave as described in the use and maintenance manual by the manufacturer of the Cardan shaft installed.

9. CLEANING

ATTENTION GENERAL HAZARD

Only qualified operators and which have read and understood the safety prescriptions (Chap. 2) can carry out the operations described below. Moreover, they must check that there are no persons, animals and objects exposed in the dangerous area.

ATTENTION

During cleaning, use cut-proof gloves and accident-prevention shoes and pay particular attention not to put hands onto the hoes/blades.

The operator must clean the tiller on solid, flat ground and must take the tiller to the zero energy state

If compressed air is used to clean the machine, appropriate glasses are needed.

It is good practice to wash the equipment externally with a jet of water after every job.



ATTENTION CUTTING HAZARD



Clean the tiller with a jet of water (high-pressure water jet machine) especially the following parts:

- frame surface
- hoes/blades
- mast
- cover
- rotor

Dry using compressed air after washing.

To be able to clean the rotor compartment:

- Lift the rear cover
- fix the chain in the relative hook
- if it is not possible to access the rear compartment, access the front compartment.

When washing has been completed, protect the metal parts that are not painted with lubricant oil

10. STORAGE AND WINTERING

If the machine is immobilised for long periods, it must be stored in a place sheltered from atmospheric conditions and be protected to avoid damage. Before setting it aside, clean the whole machine and lubricate all mechanical parts to protect them from rust.

Before setting the machine aside for long periods, operate as follows:

- free the rotor and the tools from tilling residues
- clean the machine thoroughly
- carry out a general visual control of the machine to identify structural damage, to detect deep paint abrasions, to check that all original safety pictograms are in place, and that they are integral and legible
- grease all mechanical parts and fastening pins
- if possible, recover the machine in a covered place, on flat and consistent ground.



If the machine has disk safety devices (clutch), after having made note of the height of the compressed springs, it is recommended to loosen the screws (see par. 6.2) that compress the springs in order to prevent that the disks block against each other (seizure).

11. SCRAPPING

In the event of scrapping, the machine must be disposed of in suitable waste disposal sites, in compliance with the Law in force.

In Italy, before scrapping, separate the plastic or rubber parts from the metal ones. The parts made only in plastic, aluminium, steel, can be re-cycled, if collected by appropriate centres.

Recover any waste oils and dispose of them in the relevant collection centres. Used oil must be recovered and not be dispersed in the environment, because, according to the legal Standards in force, it is classified as dangerous waste and as such must be brought to the appropriate collection centres. For the collection of waste oils, it is mandatory to connect the "Consorzio Obbligatorio Oli Usati" (Mandatory Consortium for Used Oils) (www.coou.it; free phone 800-863048).

For the other countries, refer to the relative anti-pollution regulations in force.

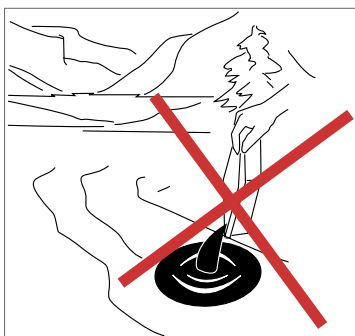

12. QUICK CONSULTATION TABLES

The following pages, state the conditions and hypothesis of intervention for each of the cases stated above, in table form.

12.1 COUPLING TORQUE TABLE

Check the efficiency of all screws and bolts every day. If necessary, replace them immediately and repositioning them (screws, washer, nut) in the same sequence as they were removed.

COUPLING TORQUE				
Threading	bolt class			
	8.8		10.9	
	Nm	Lb-ft	Nm	Lb-ft
M6	11	8.5	17	12
M8	28	20	40	30
M10	55	40	80	60
M12	95	70	140	105
M14	150	110	225	165
M16	240	175	305	225
M18	330	250	475	350

12.2 TROUBLESHOOTING



NOTE

Before performing the solutions suggested, make another attempt at functioning to see if the anomaly persists. In the event of intervention, start at the most elementary solution. If the anomaly remains in spite of the solutions, contact the manufacturer's after-sales centres.

ANOMALY	CAUSE	REMEDY
Oil leak from the gear box or lateral drive sump	<ul style="list-style-type: none"> Too much oil in the box or lateral sump Vent cap with faulty valve Load/drain/level caps loose Damaged gaskets 	<ul style="list-style-type: none"> Restore the correct oil level Replace the vent cap Tighten the load/drain/level caps Replace the gaskets
Tilling not uniform	<ul style="list-style-type: none"> Worn or damaged tools Machine not well adjusted (unaligned skids or rollers) Machine clogged 	<ul style="list-style-type: none"> Replace the tools Carry out adjustments Decrease tractor advancement speed Clean the tilling chamber
Bevel gear unit overheating	<ul style="list-style-type: none"> Insufficient oil No oil Heavy ground 	<ul style="list-style-type: none"> Top-up the oil Restore the oil level Reduce advancement speed
Premature tool wear	<ul style="list-style-type: none"> Sandy or muddy ground 	<ul style="list-style-type: none"> Reduce advancement speed
Tools breakage	<ul style="list-style-type: none"> Stony ground 	<ul style="list-style-type: none"> Reduce advancement speed
Machine noise or vibrations	<ul style="list-style-type: none"> Very hard ground Rotor unbalanced or damaged Damaged, worn or missing tools Worn bearings PTO not correctly positioned with respect to the tractor PTO The tiller works too tilted forward or in reverse 	<ul style="list-style-type: none"> Reduce advancement speed Check/replace the rotor Check/replace the tools Replace bearings Adjust the Cardan shaft correctly Adjust the upper third point so that the tiller surface is parallel to the ground

ANOMALY	CAUSE	REMEDY
Excessive power absorption	<ul style="list-style-type: none"> • Volume of land worked too high • Excessive work depth • Excessive rotor rotation speed • Tilling chamber clogging (humid land) 	<ul style="list-style-type: none"> • Decrease working depth by regulating skid heights • Reduce gear speed • Lift the rear cover to facilitate the escape of earth
Little pulverization of the land	<ul style="list-style-type: none"> • Rear cover too open • Excessive advancement speed • Rotor rotation speed too slow 	<ul style="list-style-type: none"> • Lower rear cover • Reduce advancement speed • Increase gear speed
The tiller bounces of the land	<ul style="list-style-type: none"> • Hoes positioning not helical • Hoes inverted, worn or broken • Rotor deformed or with foreign bodies between the hoes • Ground too hard 	<ul style="list-style-type: none"> • Restore the correct helical positioning of the hoes • Replace the hoes • Replace the rotor • Pass several times

12.3 LUBRICATION INTERVALS

	INTERVAL IN HOURS	DESCRIPTION OF THE INTERVENTION
A	AFTER THE FIRST 50 HOURS OF WORK	<ul style="list-style-type: none"> • replace the oil in the gear unit box
B	EVERY 8 HOURS OF WORK	<ul style="list-style-type: none"> • grease the rear roll supports
C	EVERY 50 HOURS OF WORK	<ul style="list-style-type: none"> • check the oil level in the gear box unit and top-up to the correct level if necessary • check the oil level in the lateral drive sump and top-up if necessary • check the oil level in the lateral support of the external rotor and top-up if necessary
D	EVERY 500 HOURS OF WORK	<ul style="list-style-type: none"> • replace the oil in the gear unit box • replace the oil in the lateral drive sump • replace the oil in the lateral support of the external rotor

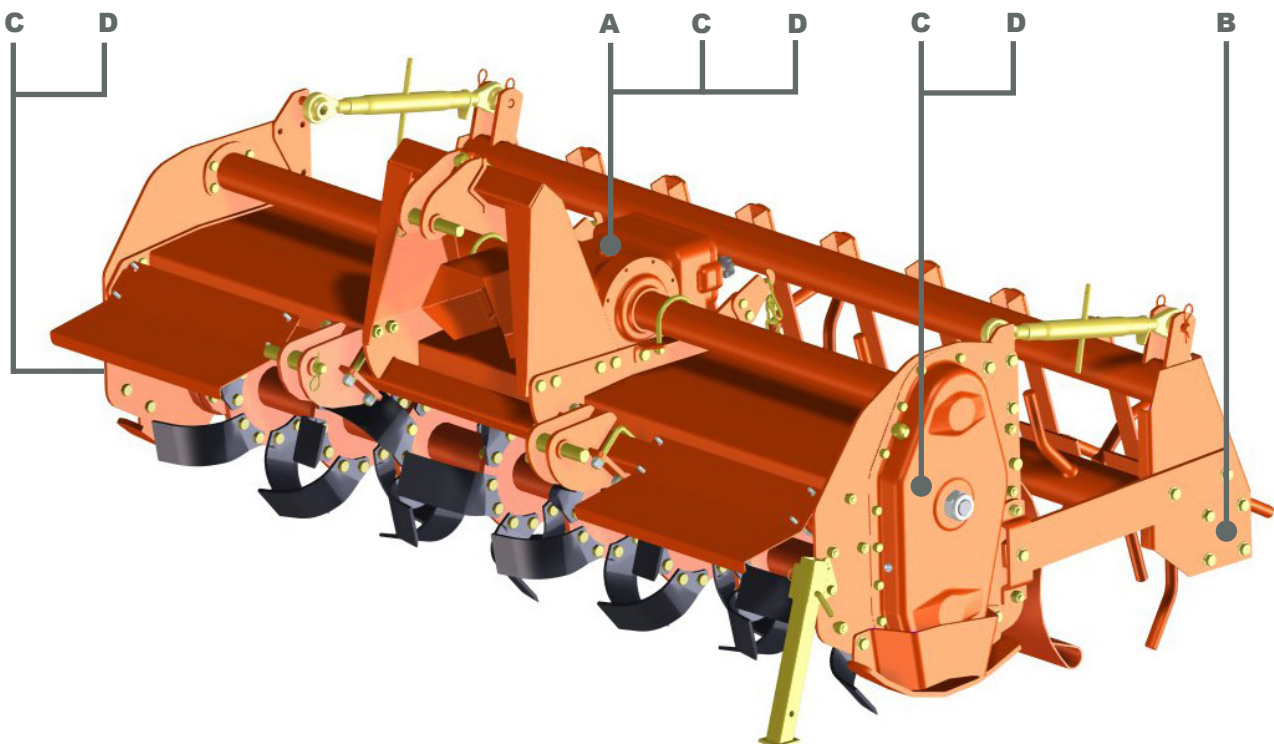

RECOMMENDED LUBRICANTS	
OIL	AGIP-ENI BLASIA 150
GREASE	AGIP GREASE MU EP 2

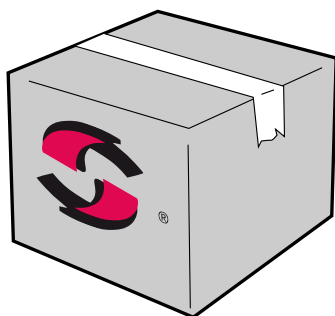

13. SPARE PARTS

Repairs and replacements must be performed using original spare parts, which must be requested from the Dealer. Remember that the request for spare parts must be correct and accompanied by the following indications:

- machine type;
- serial number;
- code and description of the spare part requested can be obtained from the Spare Parts Exploded Diagram;
- quantity requested.

Given the particular stress to which the equipment is subjected and for safety reasons, if pieces are replaced, only use original spare parts.

14. WARRANTY

In order to make use of the contractual warranty supplied by the Manufacturer, the operator must scrupulously comply with the precautions indicated in the Use and Maintenance Manual and in particular:

- respect the limits of use envisioned by the Manufacturer;
- do not make modifications or variations to the machine without the written approval of the Manufacturer;
- always perform all maintenance interventions prescribed;
- always use original spare parts;
- make sure that the staff assigned to using the vehicle has the necessary skill requisites and training.

The contractual warranty is not applied if the conditions stated above are not respected, even also partially.

The use of spare parts not approved by the Manufacturer invalidates any warranty and relieves the Manufacturer or Dealer from any liability due to malfunctioning or accidents.

The removal or the modification of guards and protections relieves the Manufacturer from all liability due to damage/injury caused to objects and/or persons.

Type: FRESATRICE
Mod.: RM
Rev.: 00/2011
Drw: 1/6

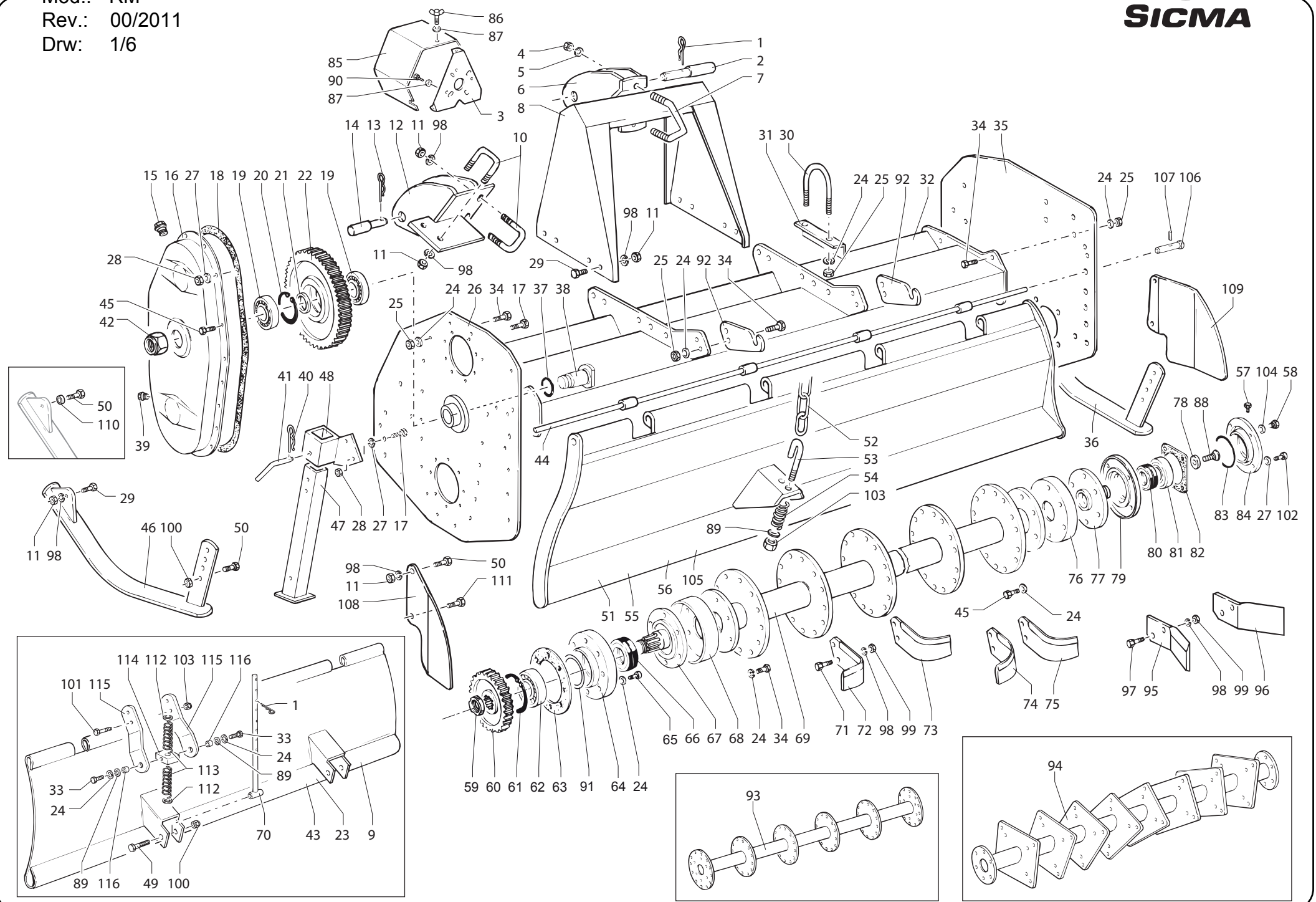

Type: FRESATRICE
Mod.: RM
Rev.: 00/2011
Drw: 2/6

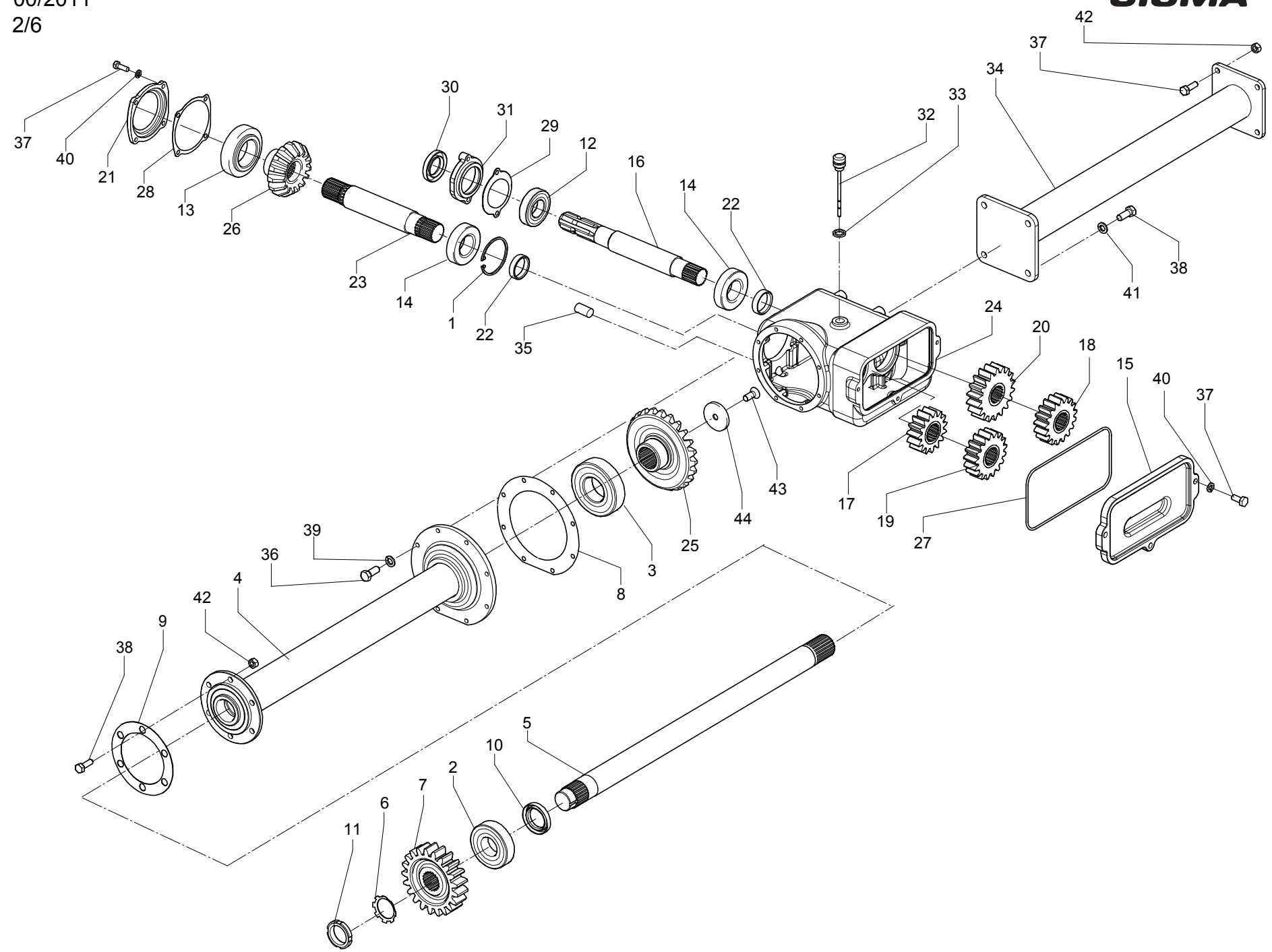

Type: FRESATRICE
Mod.: RM
Rev.: 00/2011
Drw: 3/6

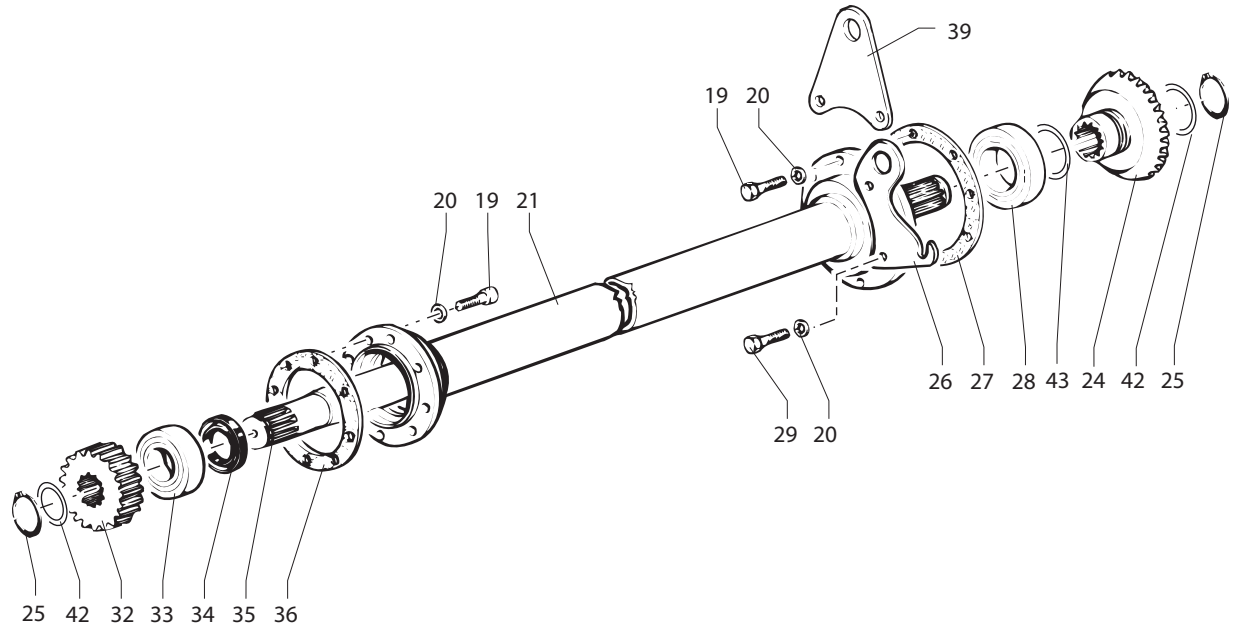
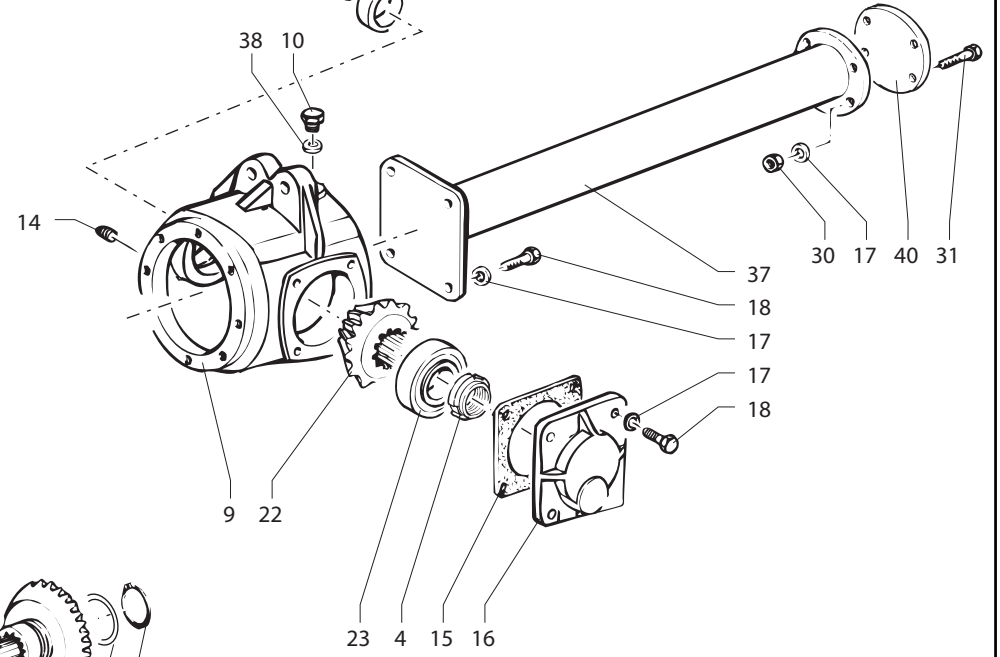
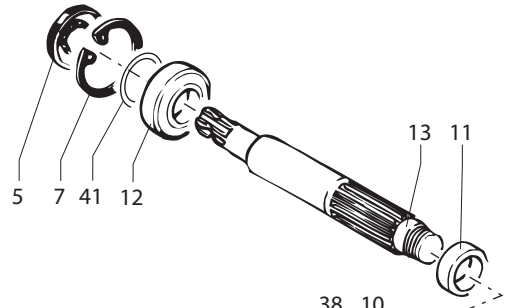
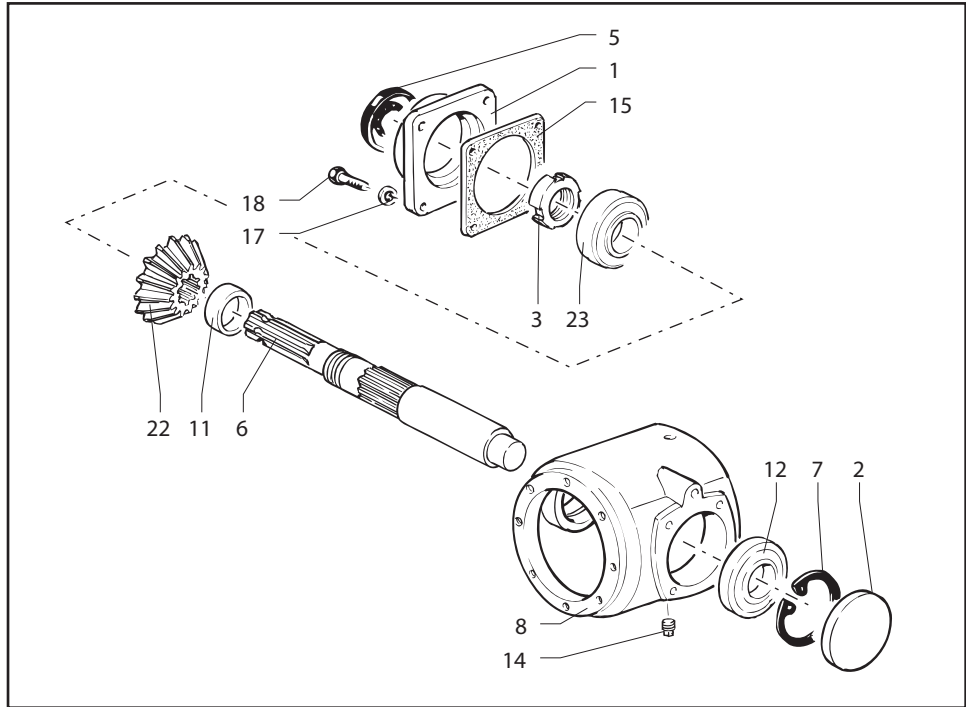

Type: FRESATRICE
Mod.: RM
Rev.: 00/2011
Drw: 4/6

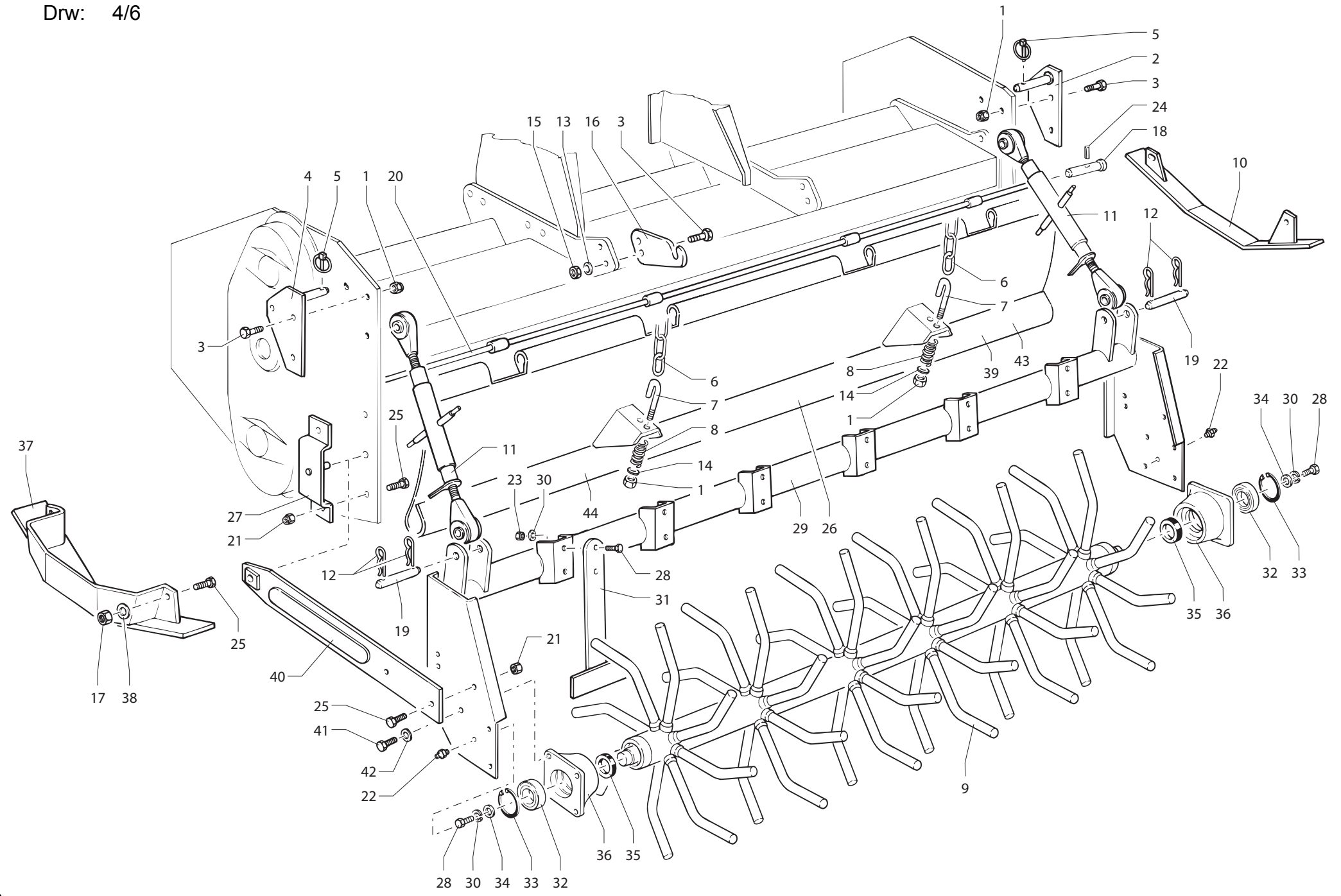

Type: FRESATRICE
Mod.: RM
Rev.: 00/2011
Drw: 5/6

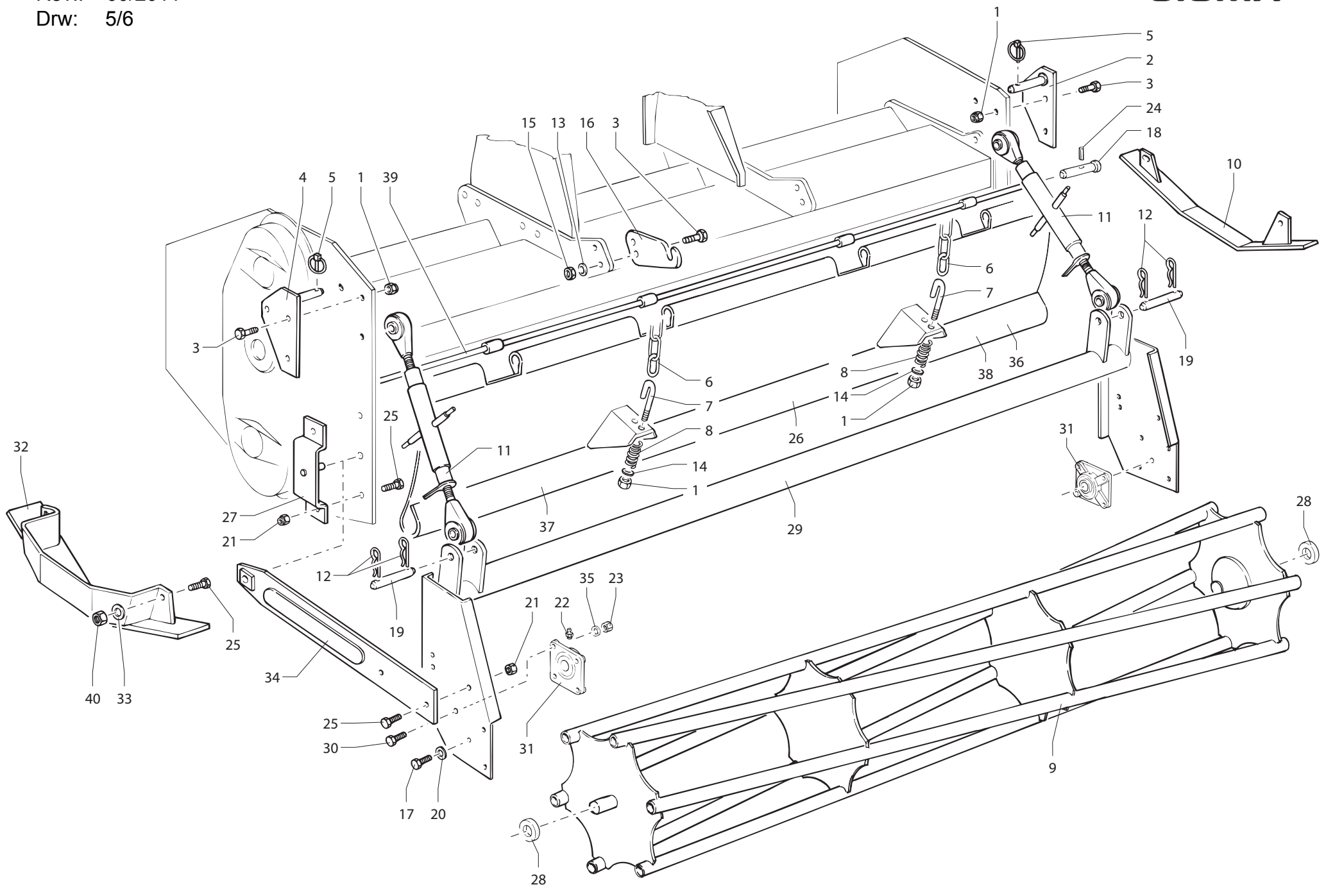

Type: FRESATRICE
Mod.: RM
Rev.: 00/2011
Drw: 6/6

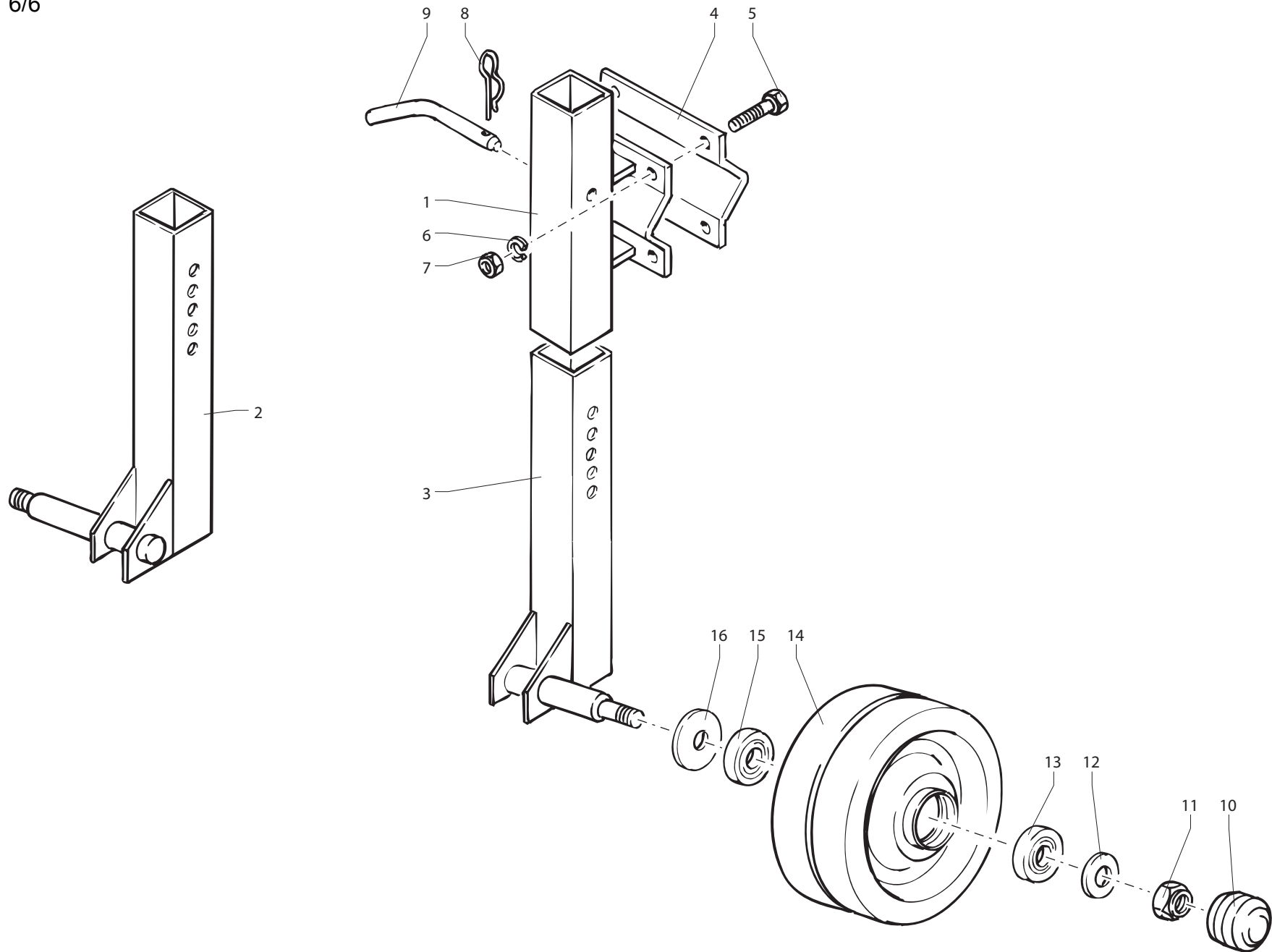

RIF.	CODICE	DENOMINAZIONE	DESCRIPTION	BENENNUNG	DESIGNATION
1	6351004	Copiglia a "R" ø 4x80	Split pin ø 4x80	Splint ø 4x80	Coupille ø 4x80
2	5304001	Perno 3° punto superiore	Pin	Bolzen	Axe
3	4138035	Supporto protezione giunto	Protection support	Halterung	Support
4	34100016	Dado M16 PG UNI 5587	Nut M16 PG UNI 5587	Mutter M16 PG UNI 5587	Ecrou M16 PG UNI 5587
5	34121016	Rondella grower ø 16 UNI 1751	Washer ø 16 UNI 1751	Scheibe ø 16 UNI 1751	Rondelle ø 16 UNI 1751
6	4007937	3° punto superiore	Plate	Verbindungstuuck 3° punkt	Cadre 3° point
7	4302257	Cravatta bloccaggio ST-SM	"U" Screw	Halter	Etrier
8	4008697	Attacco 3° punto superiore	Plate	Verbindungstück 3° punkt	Cadre 3° point
9	4007984	Coperchio corto tipo "C" SM-235 Sx	Left cover SM-235	Linkes deckel SM-235	Couvercle gauche SM-235
10	4307802	Cravatta quadra 3° punto inf.	"U" Screw	Halter	Etrier
11	34100014	Dado M14 PG UNI 5587	Nut M14 PG UNI 5587	Mutter M14 PG UNI 5587	Ecrou M14 PG UNI 5587
12	4007935	Attacco 3° punto inferiore dx	Plate	Verbindungstück 3° punkt	Cadre 3° point
12	4007936	Attacco 3° punto inferiore sx	Plate	Verbindungstück 3° punkt	Cadre 3° point
13	6351004	Copiglia a "R" ø 4x80	Split pin ø 4x80	Splint ø 4x80	Coupille ø 4x80
14	4309179	Perno 3° punto inferiore	Pin	Bolzen	Axe
15	3442122	Tappo conico con sfiato M22X1.5	Plug M22x1,5	Auspuffpropfen M22x1,5	Bouchon M22x1,5
16	4008302	Carter trasmissione	Gearbox	Carter	Carter
17	31510025	Vite M10x1,5x25 UNI 5739	Screw M10x1,5x25 UNI 5739	Schraube M10x1,5x25 UNI 5739	Vis M10x1,5x25 UNI 5739
18	4788398	Guarnizione cop. trasmissione	Gasket	Dichtung	Joint
19	2030210	Cuscinetto 30210	Bearing 30210	Lager 30210	Roulement 30210
20	6310090	Seeger I ø 90	Circlip I ø 90	Seegersicherung I ø 90	Bague d'arrêt I ø 90
21	4598239	Distanziale ingranaggio di rinvio	Spacer	Abstandstück	Entretoise
22	4728017	Ingranaggio di rinvio Z=41	Intermediate gear Z=41	Zhanrad Z=41	Engrangement Z=41
23	4007983	Coperchio corto tipo "C" SM-235 Dx	Right cover SM-235	Rechtes deckel SM-235	Couvercle droit SM-235
24	34121012	Rondella grower ø 12 UNI 1751	Washer ø 12 UNI 1751	Scheibe ø 12 UNI 1751	Rondelle ø 12 UNI 1751
25	34100012	Dado M12 PG UNI 5587	Nut M12 PG UNI 5587	Mutter M12 PG UNI 5587	Ecrou M12 PG UNI 5587
26	4008303	Piastra lato trasmissione	Plate	Platte	Plaque
27	34121010	Rondella grower ø 10 UNI 1751	Washer ø 10 UNI 1751	Scheibe ø 10 UNI 1751	Rondelle ø 10 UNI 1751
28	34100010	Dado M10 PG UNI 5587	Nut M10 PG UNI 5587	Mutter M10 PG UNI 5587	Ecrou M10 PG UNI 5587
29	31514035	Vite M14x2x35 UNI 5739	Screw M14x2x35 UNI 5739	Schraube M14x2x35 UNI 5739	Vis M14x2x35 UNI 5739
30	4332278	Cravatta fissaggio supporto	U Screw	Halter	Etrier
31	4137741	Angolare per cravatta fissaggio	Support	Lager	Support
32	4007901	Telaio SM-110	Frame SM-110	Gestell SM-110	Cadre SM-110
32	4007902	Telaio SM-120	Frame SM-120	Gestell SM-120	Cadre SM-120
32	4007903	Telaio SM-135	Frame SM-135	Gestell SM-135	Cadre SM-135
32	4007904	Telaio SM-150	Frame SM-150	Gestell SM-150	Cadre SM-150
32	4007905	Telaio SM-160	Frame SM-160	Gestell SM-160	Cadre SM-160
32	4007911	Telaio SM-170	Frame SM-170	Gestell SM-170	Cadre SM-170
32	4007906	Telaio SM-185	Frame SM-185	Gestell SM-185	Cadre SM-185
32	4007907	Telaio SM-210	Frame SM-210	Gestell SM-210	Cadre SM-210
32	4007908	Telaio SM-235	Frame SM-235	Gestell SM-235	Cadre SM-235
33	31512025	Vite M12x1,75x25 UNI 5739	Screw M12x1,75x25 UNI 5739	Schraube M12x1,75x25 UNI 5739	Vis M12x1,75x25 UNI 5739
34	31512035	Vite M12x1,75x35 UNI 5739	Screw M12x1,75x35 UNI 5739	Schraube M12x1,75x35 UNI 5739	Vis M12x1,75x35 UNI 5739
35	4937902	Piastra lato esterno	External side plate	Platte	Plaque
36	4007002	Slitta dx	Right skid	Rechter schlitten	Clissière droite
37	6836220	Guarnizione O.R. 220	O. Ring 220	O. Ring 220	Bague d'étanchéité 220
38	4208110	Perno ingranaggio di rinvio	Pin	Bolzen	Axe
39	3444114	Tappo conico con oblò M14x1.5	Plug M14x1,5	Öelstopfen M14x1,5	Bouchon M14x1,5
40	6351003	Coppiglia a "R" ø 3x60	Split pin "R" ø 3x60	Splint "R" ø 3x60	Goupille "R" ø 3x60
41	4236115	Perno bloccaggio piedino	Pin	Bolzen	Axe
42	34109033	Dado autobl.M33 PF UNI 7474 Basso	Self locking nut M33 PF UNI 7474	Nutmutter M33 UNI7474	Ecrou autobloquant M33 UNI 7474
43	4007980	Coperchio corto tipo "C" SM-160	Bonnet SM-160	Deckel SM-160	Capot SM-160
43	4007981	Coperchio corto tipo "C" SM-185	Bonnet SM-185	Deckel SM-185	Capot SM-185
43	4007982	Coperchio corto tipo "C" SM-210	Bonnet SM-210	Deckel SM-210	Capot SM-210
44	4232102	Perno coperchio SM-110	Bonnet pin SM-110	Bolzen deckel SM-110	Axe capot SM-110
44	4232103	Perno coperchio SM-120	Bonnet pin SM-120	Bolzen deckel SM-120	Axe capot SM-120
44	4232104	Perno coperchio SM-135	Bonnet pin SM-135	Bolzen deckel SM-135	Axe capot SM-135
44	4232105	Perno coperchio SM-150	Bonnet pin SM-150	Bolzen deckel SM-150	Axe capot SM-150
44	4232106	Perno coperchio SM-160	Bonnet pin SM-160	Bolzen deckel SM-160	Axe capot SM-160
44	4232109	Perno coperchio SM-170	Bonnet pin SM-170	Bolzen deckel SM-170	Axe capot SM-170
44	4232107	Perno coperchio SM-185	Bonnet pin SM-185	Bolzen deckel SM-185	Axe capot SM-185
44	4232108	Perno coperchio SM-210	Bonnet pin SM-210	Bolzen deckel SM-210	Axe capot SM-210
44	4237901	Perno coperchio SM-235	Bonnet pin SM-235	Bolzen deckel SM-235	Axe capot SM-235
45	31512030	Vite M12x1,75x30 UNI 5739	Screw M12x1,75x30 UNI 5739	Schraube M12x1,75x30	Vis M12x1,75x30 UNI 5739
46	4007003	Slitta sx	Left skid	Linker Schlitten	Glissière gauche
47	4002376	Piedino di appoggio	Foot	Fuss	Pied
48	4002377	Supporto piedino	Support	Halterung	Support
49	31314080	Vite M14x2x80 UNI 5737	Screw M14x2x80 UNI 5737	Schraube M14x2x80 UNI 5737	Vis M14x2x80 UNI 5737
50	31514040	Vite M14x2x40 UNI 5739	Screw M14x2x40 UNI 5739	Schraube M14x2x40 UNI 5739	Vis M14x2x40 UNI 5739
51	4007915	Coperchio SM-110	Bonnet SM-110	Haube SM-110	Capot SM-110
51	4007916	Coperchio SM-120	Bonnet SM-120	Haube SM-120	Capot SM-120
51	4007917	Coperchio SM-135	Bonnet SM-135	Haube SM-135	Capot SM-135
51	4007918	Coperchio SM-150	Bonnet SM-150	Haube SM-150	Capot SM-150
51	4007919	Coperchio SM-160	Bonnet SM-160	Haube SM-160	Capot SM-160
51	4007924	Coperchio SM-170	Bonnet SM-170	Haube SM-170	Capot SM-170
51	4007920	Coperchio SM-185	Bonnet SM-185	Haube SM-185	Capot SM-185
51	4007921	Coperchio SM-210	Bonnet SM-210	Haube SM-210	Capot SM-210
52	4508002	Catena coper. 15 maglie SM-170/185/210/235	Chain SM-170/185/210/235	Kette SM-170/185/210/235	Chaîne SM-170/185/210/235

RIF.	CODICE	DENOMINAZIONE	DESCRIPTION	BENENNUNG	DESIGNATION
52	4508003	Catena cop. 17 maglie SM-110/120/135/150/160	Chain SM-110/120/135/150/160	Kette SM-110/120/135/150/160	Chaîne SM-110/120/135/150/160
53	4302183	Gancio per catena	Chain plate	Metalplatte	Plaque chaîne
54	4212214	Molla ammortizzatore	Spring	Feder	Ressort
55	4007926	Coperchio SM-235 Sx	Left cover SM-235	Linkes deckel SM-235	Couvercle gauche SM-235
56	4007925	Coperchio SM-235 Dx	Right cover SM-235	Rechtes deckel SM-235	Couvercle droit SM-235
57	3441014	Tappo olio	Plug	Auspuffpropfen	Bouchon
58	3444014	Tappo livello olio	Plug	Auspuffpropfen	Bouchon
59	34127035	Ghiera autobl. ø 35x1,5 GUP	Self locking nut ø 35x1,5 GUP	Selbstperendmutter ø 35x1,5 GUP	Collier autobl. ø 35x1,5 GUP
60	4728335	Ingranggio condotto Z=32	Gear Z=32	Zahnrad Z=32	Engrenage Z=32
61	6310100	Seeger I ø 100	Circlip I ø 100	Seegersicherung I ø 100	Bague d'arrêt I ø 100
62	2821309	Cuscinetto 21309	Bearing 21309	Lager 21309	Roulement 21309
63	4788217	Guarnizione supp. ingranaggio	Gasket	Dichtung	Joint
64	4708702	Supporto mozzo ingranaggio	Support	Halterung	Support
65	31712025	Vite TCEI M12x1,75x25 UNI 5931	Screw TCEI M12x1,75x25 UNI 5931	Schraube TCEI M12x1,75x25 UNI 5931	Vis TCEI M12x1,75x25 UNI 5931
66	6203707	Gruppo GNL 5470	Oil seal GNL 5470	Oelabdichtung GNL 5470	Pare-huile GNL 5470
67	4728200	Mozzo ingranaggio condotto	Hub	Nabe	Moyeur
68	4148040	Coperchio parapolvere trasm.	Dust cover	Deckel	Couvercle
69	4007815	Rotore porta zappe SM-110	Blades holder rotor SM-110	Rotor SM-110	Rotor SM-110
69	4007816	Rotore porta zappe SM-120	Blades holder rotor SM-120	Rotor SM-120	Rotor SM-120
69	4007940	Rotore porta zappe SM-135	Blades holder rotor SM-135	Rotor SM-135	Rotor SM-135
69	4007941	Rotore porta zappe SM-150	Blades holder rotor SM-150	Rotor SM-150	Rotor SM-150
69	4007942	Rotore porta zappe SM-160	Blades holder rotor SM-160	Rotor SM-160	Rotor SM-160
69	4007946	Rotore porta zappe SM-170	Blades holder rotor SM-170	Rotor SM-170	Rotor SM-170
69	4007943	Rotore porta zappe SM-185	Blades holder rotor SM-185	Rotor SM-185	Rotor SM-185
69	4007944	Rotore porta zappe SM-210	Blades holder rotor SM-210	Rotor SM-210	Rotor SM-210
69	4007945	Rotore porta zappe SM-235	Blades holder rotor SM-235	Rotor SM-235	Rotor SM-235
70	4004030	Asta regolazione	Adjusting rod	Regulierstange	Tige de réglage
71	31414040	Vite M14x1,5x40 Fil. 20	Screw M14x1,5x40	Schraube M14x1,5x40	Vis M14x1,5x40
72	4818224	Zappa a squadra sinistra	Left square blade	Linkes winkelmesser	Couteau gauche à équerre
73	4818225	Zappa a squadra destra	Right square blade	Rechtes Winkelmesser	Couteau droite à équerre
74	4818223	Zappa curva sinistra	Left blade	Linkes messer	Couteau gauche
75	4818222	Zappa curva destra	Right blade	Rechtes messer	Couteau droite
76	4148030	Coperchio parapolvere esterno	Dust cover	Deckel	Couvercle
77	4708249	Mozzo supporto rotore	Rotor support hub	Nabe	Moyeur
78	4208021	Rondella ferma cuscinetto	Washer	Scheibe	Rondelle
79	4708239	Supporto GNL	Support GNL	Halterung GNL	Support GNL
80	6205300	Gruppo GNL JD 5300	Oil seal GNL JD 5300	Oelabdichtung GNL JD 5300	Pare-huile GNL JD 5300
81	2106307	Cuscinetto 6307	Bearing 6307	Lager 6307	Roulement 6307
82	4788219	Guarnizione supporto esterno	Gasket	Dichtung	Garniture
83	6800094	Guarnizione O.R. 240	O. Ring 240	O. Ring 240	Bague d'étanchéité 240
84	4708248	Supporto cuscinetto	Bearing support	Halterung	Support
85	4138034	Protezione giunto	Joint protection	Schutz kupplung	Protection joint
86	33108020	Vite ad alette M8x1,25x20	Screw M8x1,25x20	Schraube M8x1,25x20	Vis M8x1,25x20
87	34118008	Rondella piana ø 8 fascia larga	Washer ø 8	Scheibe ø 8	Rondelle ø 8
88	30612030	Vite TSEI M12x1,75x30	Screw M12x1,75x30	Schraube M12x1,75x30	Vis M12x1,75x30
89	34120012	Rondella piana ø 12 UNI 6592	Washer ø 12 UNI 6592	Scheibe ø 12 UNI 6592	Rondelle ø 12 UNI 6592
90	31508016	Vite M8x1,25x16 UNI 5739	Screw M8x1,25x16 UNI 5739	Schraube M8x1,25x16 UNI 5739	Vis M8x1,25x16 UNI 5739
91	6018003	Spessore ø80x 100x0.3	Shim ø80x100x0.3	Dicke ø80x100x0.3	Epaisseur ø80x100x0.3
92	4934778	Gancio catena SM-170/185/210/230	Chain plate SM-170/185/210/230	Metalplatte SM-170/185/210/230	Plaque chaîne SM-170/185/210/230
93	4007988	Rotore tipo PUGLIA SM-135	Rotor SM-135	Rotor SM-135	Rotor SM-135
93	4007989	Rotore tipo PUGLIA SM-150	Rotor SM-150	Rotor SM-150	Rotor SM-150
93	4007990	Rotore tipo PUGLIA SM-160	Rotor SM-160	Rotor SM-160	Rotor SM-160
93	4007991	Rotore tipo PUGLIA SM-185	Rotor SM-185	Rotor SM-185	Rotor SM-185
93	4007992	Rotore tipo PUGLIA SM-210	Rotor SM-210	Rotor SM-210	Rotor SM-210
93	4007993	Rotore tipo PUGLIA SM-235	Rotor SM-235	Rotor SM-235	Rotor SM-235
94	4002167	Rotolama RSM-160	Rotor RSM-160	Rotor RSM-160	Rotor RSM-160
94	4002168	Rotolama RSM-185	Rotor RSM-185	Rotor RSM-185	Rotor RSM-185
94	4002169	Rotolama RSM-210	Rotor RSM-210	Rotor RSM-210	Rotor RSM-210
94	4007947	Rotolama RSM-235	Rotor RSM-235	Rotor RSM-235	Rotor RSM-235
95	4818195	Coltello 2 fori sx	Left blade	Linkes messer	Couteau gauche
96	4818194	Coltello 2 fori dx	Right blade	Rechtes messer	Couteau droite
97	31414045	Vite M14x1,5x45 fil. 20	Screw M14x1,5x45	Schraube M14x1,5x45	Vis M14x1,5x45
98	34032014	Rondella grower ø 14 UNI 1751	Washer ø 14 UNI 1751	Scheibe ø 14 UNI 1751	Rondelle ø 14 UNI 1751
99	34101014	Dado M14 PF UNI 5587	Nut M14 PF UNI 5587	Mutter M14 PF UNI 5587	Ecrou M14 PF UNI 5587
100	34106014	Dado autobloc. M14 PG alto	Self locking nut M14 PG	Nutmutter M14 PG	Ecrou autobloquant M14 PG
101	31312050	Vite M12x1,75x50 UNI 5737	Screw M12x1,75x50 UNI 5737	Schraube M12x1,75x50 UNI 5737	Vis M12x1,75x50 UNI 5737
102	31510030	Vite M10x1,5x30 UNI 5739	Screw M10x1,5x30 UNI 5739	Schraube M10x1,5x30 UNI 5739	Vis M10x1,5x30 UNI 5739
103	34106012	Dado autobloc. M12 PG alto	Self locking nut M12 PG	Nutmutter M12 PG	Ecrou autobloquant M12 PG
104	6470114	Rondella alluminio ø 14	Washer ø 14	Scheibe ø 14	Rondelle ø 14
105	4007929	Coperchio SM-sc-135	Bonnet SM-sc-135	Haube SM-sc-135	Capot SM-sc-135
105	4007930	Coperchio SM-sc-150	Bonnet SM-sc-150	Haube SM-sc-150	Capot SM-sc-150
105	4007931	Coperchio SM-sc-160	Bonnet SM-sc-160	Haube SM-sc-160	Capot SM-sc-160
106	4232111	Perno laterale coperchio	Pin	Bolzen	Axe
107	6330636	Spina elastica	Split pin	Splint	Goupille elastique
108	4932110	Paraterra Sx	LH side earth-guard	Erdabweiser links	Garde-terre latéral gauche
109	4932109	Paraterra Dx	RH side earth-guard	Erdabweiser rechts	Garde-terre latéral droit
110	4237904	Distanziale slitta con paraterra	Spacer	Abstandstück	Entretoise
111	31514045	Vite M14x2x45 UNI 5739	Screw M14x2x45 UNI 5739	Schraube M14x2x45 UNI 5739	Vis M14x2x45 UNI 5739
112	34120020	Rondella piana ø 20 UNI 6592	Washer ø 20 UNI 6592	Scheibe ø 20 UNI 6592	Rondelle ø 20 UNI 6592

Type: FRESATRICE

Mod.: RM

Rev.: 00/2011

Tab: 1/6

Pag. 3/3

RIF.	CODICE	DENOMINAZIONE	DESCRIPTION	BENENNUNG	DESIGNATION
113	4214577	Molla premicofano	Spring	Feder	Ressort
114	4834001	Quadro asta regolazione	Frame	Rahmen	Cadre
115	4834002	Braccio registro coperchio	Arm	Arm	Bras
116	4534002	Distanziale snodo	Spacer	Abstandstück	Entretoise

RIF.	CODICE	DENOMINAZIONE	DESCRIPTION	BENENNUNG	DESIGNATION
1	6310080	Seeger per fori Ø80 DIN 472	Internal circlip Ø80 DIN 472	Seegersicherung Ø80 DIN 472	Bague d'arrêt E Ø80 DIN 472
2	2030309	Cuscinetto 32209	Bearing 32209	Lager 32209	Roulement 32209
3	2732212	Cuscinetto 32212	Bearing 32212	Lager 32212	Roulement 32212
4	4008020	Supporto albero RM/110	Extension tube RM/110	Halterung RM/110	Support RM/110
4	4008021	Supporto albero RM/120	Extension tube RM/120	Halterung RM/120	Support RM/120
4	4008022	Supporto albero RM/135	Extension tube RM/135	Halterung RM/135	Support RM/135
4	4008023	Supporto albero RM/150	Extension tube RM/150	Halterung RM/150	Support RM/150
4	4008024	Supporto albero RM/160	Extension tube RM/160	Halterung RM/160	Support RM/160
4	4008025	Supporto albero RM/170	Extension tube RM/170	Halterung RM/170	Support RM/170
4	4008026	Supporto albero RM/185	Extension tube RM/185	Halterung RM/185	Support RM/185
4	4008027	Supporto albero RM/210	Extension tube RM/210	Halterung RM/210	Support RM/210
4	4008028	Supporto albero RM/235	Extension tube RM/235	Halterung RM/235	Support RM/235
5	4217770	Albero corona RM/110	Shaft RM/110	Welle RM/110	Arbre RM/110
5	4217771	Albero corona RM/120	Shaft RM/120	Welle RM/120	Arbre RM/120
5	4217772	Albero corona RM/135	Shaft RM/135	Welle RM/135	Arbre RM/135
5	4217773	Albero corona RM/150	Shaft RM/150	Welle RM/150	Arbre RM/150
5	4217774	Albero corona RM/160	Shaft RM/160	Welle RM/160	Arbre RM/160
5	4217775	Albero corona RM/170	Shaft RM/170	Welle RM/170	Arbre RM/170
5	4217776	Albero corona RM/185	Shaft RM/185	Welle RM/185	Arbre RM/185
5	4217777	Albero corona RM/210	Shaft RM/210	Welle RM/210	Arbre RM/210
5	4217778	Albero corona RM/235	Shaft RM/235	Welle RM/235	Arbre RM/235
6	34031040	Rosetta MB M40 DIN 5406	Washer MB M40 DIN 5406	Scheibe MB M40 DIN 5406	Rondelle MB M40 DIN 5406
7	4728338	Ingranaggio conduttore Z21	Driving gear Z21	Zanhrad Z21	Engrenage Z21
8	20850-05	Guarn. supporti trasmissione	Gasket, extension tubes	Dichtung	Garniture
9	4788216	Guarn. supporto albero	Gasket, extension tube	Dichtung	Garniture
10	6204572	Paraolio 40x62x10 PP DIN 3760 tipo ASP	Oil seal 40x62x10 PP DIN 3760 tipo ASP	Oelabdichtung 40x62x10 PP DIN 3760 ASP	Pare-huile 40x62x10 PP DIN 3760 ASP
11	34008040	Ghiera KM M40x1.5 DIN981	Locking nut KM M40x1.5 DIN981	Selbstperrendmutter KM M40x1.5 DIN981	Collier autobl. KM M40x1.5 DIN981
12	2732207	Cuscinetto 32207	Bearing 32207	Lager 32207	Roulement 32207
13	2732211	Cuscinetto 32211	Bearing 32211	Lager 32211	Roulement 32211
14	2732208	Cuscinetto 32208	Bearing 32208	Lager 32208	Roulement 32208
15	16750-01	Coperchio cambio	Gearbox cover	Carter	Carter
16	12250-05	Albero presa di forza	PTO shaft	Welle	Arbre
17	12250-01	Ingranaggio Z15	Gear Z15	Zanhrad Z15	Engrenage Z15
18	12250-02	Ingranaggio Z16	Gear Z16	Zanhrad Z16	Engrenage Z16
19	12250-03	Ingranaggio Z17	Gear Z17	Zanhrad Z17	Engrenage Z17
20	12250-04	Ingranaggio Z18	Gear Z18	Zanhrad Z18	Engrenage Z18
21	17050-01	Supporto pignone	Pinion bearing	Support	Support
22	25450-01	Distanziale	Spacer	Distanzstück	Entretoise
23	12150-01	Albero pignone	Pinion shaft	Shaft	Arbre
24	16550-01	Carter coppia conica	Gearbox housing	Carter	Carter
25	17250-02	Corona conica Z24	Bevel gear Z24	Kegelradkranz Z24	Couronne conique Z24
26	17250-01	Pignone conico Z15	Bevel pinion Z15	Ritzel Z15	Pignon conique Z=15
27	20950-01	Guarnizione coperchio cambio	Gasket, gearbox cap	Dichtung	Garniture
28	20850-01	Guarnizione coperchio (sp.0.2mm)	Gasket, pinion cap(sp.0.2mm)	Dichtung (sp.0.2mm)	Garniture (sp.0.2mm)
28	20850-02	Guarnizione coperchio (sp.0.3mm)	Gasket, pinion cap(sp.0.3mm)	Dichtung (sp.0.3mm)	Garniture (sp.0.3mm)
28	20850-03	Guarnizione coperchio (sp.0.5mm)	Gasket, pinion cap(sp.0.5mm)	Dichtung (sp.0.5mm)	Garniture (sp.0.5mm)
29	20850-04	Guarnizione coperchio PTO	Gasket, PTO shaft	Dichtung	Garniture
30	6203562	Paraolio 35x62x10 PP	Oil seal 35x62x10 PP	Oelabdichtung 35x62x10 PP	Pare-huile 35x62x10 PP
31	17050-02	Supporto albero PTO	PTO shaft bearing	Support	Support
32	25250-01	Tappo valvola elivello M22x1,5	Oil level plug M22x1,5	Oelstopfen M22x1,5	Bouchon M22x1,5
33	6470118	Rondella di tenuta M22 (Al/Cu)	Gasket M22 (Al/Cu)	Scheibe M22	Rondelle M22
34	4007821	Supporto lato esterno RM/110	Extension tube RM/110	Halterung RM/110	Support RM/110
35	4007822	Supporto lato esterno RM/120	Extension tube RM/120	Halterung RM/120	Support RM/120
35	4007956	Supporto lato esterno RM/135	Extension tube RM/135	Halterung RM/135	Support RM/135
35	4007957	Supporto lato esterno RM/150	Extension tube RM/150	Halterung RM/150	Support RM/150
35	4007958	Supporto lato esterno RM/160	Extension tube RM/160	Halterung RM/160	Support RM/160
35	4007962	Supporto lato esterno RM/170	Extension tube RM/170	Halterung RM/170	Support RM/170
35	4007959	Supporto lato esterno RM/185	Extension tube RM/185	Halterung RM/185	Support RM/185
35	4007960	Supporto lato esterno RM/210	Extension tube RM/210	Halterung RM/210	Support RM/210
35	4007961	Supporto lato esterno RM/235	Extension tube RM/235	Halterung RM/235	Support RM/235
35	3441022	Tappo conico M22x1.5	Oil plug M22x1.5	Oelstopfen M22x1.5	Bouchon M22x1.5
36	3022108025	Vite TE M8x25 UNI 5739 PG 10.9	Screw M8x1,25x25 UNI 5739	Schraube M8x1,25x25 UNI 5739	Vis M8x1,25x25 UNI 5739
37	3021108025	Vite M8x25 UNI 5739	Screw M8x25 UNI 5739	Schraube M8x25 UNI 5739	Vis M8x25 UNI 5739
38	3021112030	Vite M12x30 UNI 5739	Screw M12x30 UNI 5739	Schraube M12x30 UNI 5739	Vis M12x30 UNI 5739
39	3645200008	Rosetta schnorr M8 ZnB	Schnorr M8	Schnorr M8	Schnorr M8
40	3625000008	Rosetta Grower M8 UNI 1751	Grower M8 UNI 1751	Grower M8 UNI 1751	Grower M8 UNI 1751
41	3645200012	Rosetta schnorr M12 ZnB	Schnorr M12	Schnorr M12	Schnorr M12
42	34140010	Dado autob. metal. M10 DIN 980	Self lock. metal nut M10 DIN 980	Mutter M10 DIN 980	Ecrou autobloquant M10 DIN 980
43	30614035	Vite TSEI M14x35 UNI 5933	Screw TSEI M14x35 UNI 5933	Schraube TSEI M14x35 UNI 5933	Vis TSEI M14x35 UNI 5933
44	4934311	Rondella bloccaggio corona	Bevel gear locking disc	Scheibe	Rondelle

RIF.	CODICE	DENOMINAZIONE	DESCRIPTION	BENENNUNG	DESIGNATION
1	4007796	Supp. cuscinetto anteriore	Support	Halterung	Support
2	6100072	Cappello di chiusura ø 72	Cover ø 72	Deckel ø 72	Couvercle ø 72
3	34127040	Ghiera autobl. ø 40x1,5 GUP	Self looking nut ø 40x1,5 GUP	Selbstperrendmutter ø 40x1,5 GUP	Collier autobl. ø 40x1,5 GUP
4	34127035	Ghiera autobl. ø 35x1,5 GUP	Self looking nut ø 35x1,5 GUP	Selbstperrendmutter ø 35x1,5 GUP	Collier autobl. ø 35x1,5 GUP
5	6203572	Paraolio ø 35x72x10 PP	Oil seal ø 35x72x10 PP	Oelabdichtung ø 35x72x10 PP	Pare-huile ø 35x72x10 PP
6	4227795	Albero PTO rot. Sx	Shaft	Welle	Arbre
7	6310072	Seeger I ø 72	Circlip I ø 72	Seegersicherung I ø 72	Bague d'arrêt I ø 72
8	4657745	Carter coppia conica rot. Sx	Gearbox	Carter	Carter
9	4657744	Carter coppia conica	Gearbox	Carter	Carter
10	3442018	Tappo valvola M18x1,5	Plug M18x1,5	Auspuffpfropfen M18x1,5	Bouchon M18x1,5
11	4599031	Boccola distanziale	Bushing	Buchse	Douille
12	2106207	Cuscinetto 6207	Bearing 6207	Lager 6207	Roulement 6207
13	4227742	Albero presa di forza	Shaft	Welle	Arbre
14	3441018	Tappo conico olio M18x1,5	Plug M18x1,5	Auspuffpfropfen M18x1,5	Bouchon M18x1,5
15	4788219	Guarnizione	Gasket	Dichtung	Garniture
16	4647745	Coperchio fermo pignone	Cover	Deckel	Couvercle
17	34021012	Rondella grower ø 12 UNI 1751	Washer ø 12 UNI 1751	Scheibe ø 12 UNI 1751	Rondelle ø 12 UNI 1751
18	30212030	Vite M12x1,75x30 UNI 5739	Screw M12x1,75x30 UNI 5739	Schraube M12x1,75x30 UNI 5739	Vis M12x1,75x30 UNI 5739
19	30210025	Vite M10x1,5x25 UNI 5739	Screw M10x1,5x25 UNI 5739	Schraube M10x1,5x25 UNI 5739	Vis M10x1,5x25 UNI 5739
20	34021010	Rondella grower ø 10 UNI 1751	Washer ø 10 UNI 1751	Scheibe ø 10 UNI 1751	Rondelle ø 10 UNI 1751
21	4007963	Supp. albero corona SM-sc-135	Support SM-sc-135	Halterung SM-sc-135	Support SM-sc-135
21	4007964	Supp. albero corona SM-sc-150	Support SM-sc-150	Halterung SM-sc-150	Support SM-sc-150
21	4007965	Supp. albero corona SM-sc-160	Support SM-sc-160	Halterung SM-sc-160	Support SM-sc-160
21	4007969	Supp. albero corona SM-sc-170	Support SM-sc-170	Halterung SM-sc-170	Support SM-sc-170
21	4007966	Supp. albero corona SM-sc-185	Support SM-sc-185	Halterung SM-sc-185	Support SM-sc-185
21	4007967	Supp. albero corona SM-sc-210	Support SM-sc-210	Halterung SM-sc-210	Support SM-sc-210
21	4007968	Supp. albero corona SM-sc-235	Support SM-sc-235	Halterung SM-sc-235	Support SM-sc-235
22	4728643	Pignone conico Z=15	Pinion Z=15	Ritzel Z=15	Pignon conique Z=15
23	2030308	Cuscinetto 30308	Bearing 30308	Lager 30308	Roulement 30308
24	4728642	Corona conica Z=22	Ring bevel gear Z=22	Kegelradkranz Z=22	Couronne conique Z=22
25	6320045	Seeger E ø 45	Circlip E ø 45	Seegersicherung E ø 45	Bague d'arrêt E ø 45
26	4148067	Piastra att. catena SM-135/150/160	Chain plate SM-135/150/160	Metallplatte SM-135/150/160	Plaque chaine SM-135/150/160
27	4788413	Guarnizione lato corona	Gasket	Dichtung	Garniture
28	2006311	Cuscinetto 6311	Bearing 6311	Lager 6311	Roulement 6311
29	30210030	Vite M10x1,75x30 UNI 5739	Screw M10x1,75x30 UNI 5739	Schraube M10x1,75x30 UNI 5739	Vis M10x1,75x30 UNI 5739
30	34000012	Dado M12 PG UNI 5587	Nut M12 PG UNI 5587	Mutter M12 PG UNI 5587	Ecrou M12 PG UNI 5587
31	30212040	Vite M12x1,75x40 UNI 5739	Screw M12x1,75x40 UNI 5739	Schraube M12x1,75x40 UNI 5739	Vis M12x1,75x40 UNI 5739
32	4728338	Ingranaggio conduttore Z=21	Driving gear Z=21	Zahnrad Z=21	Engrenage Z=21
33	2000309	Cuscinetto NJ 309 EC	Bearing NJ 309 EC	Lager NJ 309 EC	Roulement NJ 309 EC
34	6204572	Paraolio ø 45x72x10 PP	Oil seal ø 45x72x10 PP	Oelabdichtung ø 45x72x10 PP	Pare-huile ø 45x72x10 PP
35	4217761	Albero corona SM-sc-135	Shaft SM-sc-135	Welle SM-sc-135	Arbre SM-sc-135
35	4217762	Albero corona SM-sc-150	Shaft SM-sc-150	Welle SM-sc-150	Arbre SM-sc-150
35	4217763	Albero corona SM-sc-160	Shaft SM-sc-160	Welle SM-sc-160	Arbre SM-sc-160
35	4217764	Albero corona SM-sc-170	Shaft SM-sc-170	Welle SM-sc-170	Arbre SM-sc-170
35	4217765	Albero corona SM-sc-185	Shaft SM-sc-185	Welle SM-sc-185	Arbre SM-sc-185
35	4217766	Albero corona SM-sc-210	Shaft SM-sc-210	Welle SM-sc-210	Arbre SM-sc-210
35	4217767	Albero corona SM-sc-235	Shaft SM-sc-235	Welle SM-sc-235	Arbre SM-sc-235
36	4788693	Guarnizione lato trasmissione	Gasket	Dichtung	Garniture
37	4007956	Supporto lato esterno SM-135	External support SM-135	Halterung SM-135	Support SM-135
37	4007957	Supporto lato esterno SM-150	External support SM-150	Halterung SM-150	Support SM-150
37	4007958	Supporto lato esterno SM-160	External support SM-160	Halterung SM-160	Support SM-160
37	4007962	Supporto lato esterno SM-170	External support SM-170	Halterung SM-170	Support SM-170
37	4007959	Supporto lato esterno SM-185	External support SM-185	Halterung SM-185	Support SM-185
37	4007960	Supporto lato esterno SM-210	External support SM-210	Halterung SM-210	Support SM-210
37	4007961	Supporto lato esterno SM-235	External support SM-235	Halterung SM-235	Support SM-235
38	6470117	Rondella alluminio ø 18	Washer ø 18	Scheibe ø 18	Rondelle ø 18
39	4937914	Attacco gancio sollevam. SM-170/185/210/235	Lifting hook connection SM-170/185/210/235	Anschluss Hubhaken SM-170/185/210/235	Connexion crochet de levage SM-170/185/210/235
40	4937912	Piastra distanziale supporto est.	Plate	Platte	Plaque
41	6015003	Spessore ø50x70x0.3	Shim ø 50x70x0.3	Dicke ø50x70x0.3	Epaisseur ø50x70x0.3
42	6014515	Spessore ø45x55x1.5	Shim ø 45x55x1.5	Dicke ø45x55x1.5	Epaisseur ø45x55x1.5
43	6015505	Spessore ø55x72x0.5	Shim ø 55x72x0.5	Dicke ø55x72x0.5	Epaisseur ø55x72x0.5

RIF.	CODICE	DENOMINAZIONE	DESCRIPTION	BENENNUNG	DESIGNATION
1	34106012	Dado autobloc. M12 PG alto	Self locking nut M12 PG	Selbstsperrendmutter M12 PG	Ecrou autobloquant M12 PG
2	4007601	Piastra attacco snodo dx	Plate	Platte	Plaque
3	31512035	Vite M12x1,75x35 UNI 5739	Screw M12x1,75x35 UNI 5739	Schraube M12x1,75x35 UNI 5739	Vis M12x1,75x35 UNI 5739
4	4007602	Piastra attacco snodo sx	Plate	Platte	Plaque
5	6350010	Spina a scatto ø 10x58	Release pin ø 10x58	Splint schnapper ø 10x58	Broche de sûreté ø 10x58
6	4678001	Catena coperchio 14 maglie	Chain	Kette	Chaîne
7	4302183	Gancio per catena	Chain plate	Metalplatte	Plaque chaîne
8	4212214	Molla ammortizzatore	Spring	Feder	Ressort
9	4007633	Rullo a spuntone SM-160	Spike roller SM-160	Zahnwalze SM-160	Rouleau à dents SM-160
9	4007635	Rullo a spuntone SM-185	Spike roller SM-185	Zahnwalze SM-185	Rouleau à dents SM-185
9	4007636	Rullo a spuntone SM-210	Spike roller SM-210	Zahnwalze SM-210	Rouleau à dents SM-210
9	4007637	Rullo a spuntone SM-235	Spike roller SM-235	Zahnwalze SM-235	Rouleau à dents SM-235
10	4007614	Protezione lato esterno	Protection	Schutz	Protection
11	4007612	Braccio registro 19/280	Arm 19/280	Arm 19/280	Bras 19/280
12	6351004	Copiglia a "R" ø 4x80	Split pin "R" ø 4x80	Splint "R" ø 4x80	Coupille "R" ø 4x80
13	34121012	Rondella grower ø 12 UNI 1751	Washer ø 12 UNI 1751	Scheibe ø 12 UNI 1751	Rondelle ø 12 UNI 1751
14	34120012	Rondella piana ø 12 UNI 6592	Washer ø 12 UNI 6592	Scheibe ø 12 UNI 6592	Rondelle ø 12 UNI 6592
15	34100012	Dado M 12 PG UNI 5587	Nut M12 PG UNI 5587	Mutter M12 PG UNI 5587	Ecrou M12 PG UNI 5587
16	4934778	Gancio catena SM-185/210/230	Chain plate SM-185/210/230	Metalplatte SM-185/210/230	Plaque chaîne SM-185/210/230
17	34100014	Dado M14 PG UNI 5587	Nut M14 PG UNI 5587	Mutter M14 PG UNI 5587	Ecrou M14 PG UNI 5587
18	4232111	Perno laterale coperchio	Pin	Bolzen	Axe
19	4304003	Perno fissaggio tirante	Pin	Bolzen	Axe
20	4232106	Perno coperchio SM-160	Pin SM-160	Bolzen SM-160	Axe SM-160
20	4232107	Perno coperchio SM-185	Pin SM-185	Bolzen SM-185	Axe SM-185
20	4232108	Perno coperchio SM-210	Pin SM-210	Bolzen SM-210	Axe SM-210
20	4237901	Perno coperchio SM-235	Pin SM-235	Bolzen SM-235	Axe SM-235
21	34106014	Dado autobloc. M14 PG alto	Self locking nut M14 PG	Selbstsperrendmutter M14 PG	Ecrou autobloquant M14 PG
22	6560010	Ingrassatore M10x1,5	Grease nipple M10x1,5	Schmiernippel M10x1,5	Graisseur M10x1,5
23	34000012	Dado M12 PG UNI 5587	Nut M12 PG UNI 5587	Mutter M12 PG UNI 5587	Ecrou M12 PG UNI 5587
24	6330636	Spina elastica	Split pin	Splint	Goupille elastique
25	31514035	Vite M14x2x35 UNI 5739	Screw M14x2x35 UNI 5739	Schraube M14x2x35 UNI 5739	Vis M14x2x35 UNI 5739
26	4007972	Coperchio corto tipo "B" SM-160	Bonnet SM-160	Deckel SM-160	Capot SM-160
26	4007973	Coperchio corto tipo "B" SM-185	Bonnet SM-185	Deckel SM-185	Capot SM-185
26	4007974	Coperchio corto tipo "B" SM-210	Bonnet SM-210	Deckel SM-210	Capot SM-210
27	4007616	Staffa fissaggio rullo	Bracket	Pratze	Bride
28	30212030	Vite M12x1,75x30 UNI 5739	Screw M12x1,75x30 UNI 5739	Schraube M12x1,75x30 UNI 5739	Vis M12x1,75x30 UNI 5739
29	4007607	Telaio rullo SM-160	Frame SM-160	Gestell SM-160	Cadre SM-160
29	4007609	Telaio rullo SM-185	Frame SM-185	Gestell SM-185	Cadre SM-185
29	4007610	Telaio rullo SM-210	Frame SM-210	Gestell SM-210	Cadre SM-210
29	4007611	Telaio rullo SM-235	Frame SM-235	Gestell SM-235	Cadre SM-235
30	34021012	Rondella grower ø 12 UNI 1751	Washer ø 12 UNI 1751	Scheibe ø 12 UNI 1751	Rondelle ø 12 UNI 1751
31	4007615	Raschiarullo	Scraper	Schrapper	Râclette
32	2106207	Cuscinetto 6207	Bearing 6207	Lager 6207	Roulement 6207
33	6310072	Seeger I ø 72	Circlip I ø 72	Seegersicherung I ø 72	Bague d'arrêt I ø 72
34	34019012	Rondella piana ø 13x48 fascia larga	Washer ø 13x48	Scheibe ø 13x48	Rondelle ø 13x48
35	6204200	Gruppo GNL MF.4200	Oil seal GNL MF.4200	Oelabdichtung GNL MF.4200	Pare-huile GNL MF.4200
36	4705001	Supporto cuscinetto	Support	Halterung	Support
37	4007613	Protezione carter trasmissione	Protection	Schutz	Protection
38	34121014	Rondella grower ø 14 UNI 1751	Washer ø 14 UNI 1751	Scheibe ø 14 UNI 1751	Rondelle ø 14 UNI 1751
39	4007978	Cop. corto tipo "B" SM-sc-160	Bonnet SM-sc-160	Deckel SM-sc-160	Capot SM-sc-160
40	4002134	Braccio laterale	Arm	Arm	Bras
41	30214030	Vite M14x2x30 UNI 5739	Screw M14x2x30 UNI 5739	Schraube M14x2x30 UNI 5739	Vis M14x2x30 UNI 5739
42	34021014	Rondella grower ø 14 UNI 1751	Washer ø 14 UNI 1751	Scheibe ø 14 UNI 1751	Rondelle ø 14 UNI 1751
43	4007975	Coperchio corto tipo "B" SM-235 Dx	Right cover SM-235	Rechtes deckel SM-235	Couvercle droit SM-235
44	4007976	Coperchio corto tipo "B" SM-235 Sx	Left cover SM-235	Linkes deckel SM-235	Couvercle gauche SM-235

Type: FRESATRICE

Mod.: RM

Rev.: 00/2011

Tab: 5/6

Pag. 1/1

RIF.	CODICE	DENOMINAZIONE	DESCRIPTION	BENENNUNG	DESIGNATION
1	34106012	Dado autobloc. M12 PG alto	Self locking nut M12 PG	Selbstsperrendmutter M12 PG	Ecrou autobloquant M12 PG
2	4007601	Piastra attacco snodo dx	Plate	Platte	Plaque
3	31512035	Vite M12x1,75x35 UNI 5739	Screw M12x1,75x35 UNI 5739	Schraube M12x1,75x35 UNI 5739	Vis M12x1,75x35 UNI 5739
4	4007602	Piastra attacco snodo sx	Plate	Platte	Plaque
5	6350010	Spina a scatto ø 10x58	Release pin ø 10x58	Splint schnapper ø 10x58	Broche de sûreté ø 10x58
6	4678001	Catena coperchio 14 maglie	Chain	Kette	Chaîne
7	4302183	Gancio per catena	Chain plate	Metalplatte	Plaque chaîne
8	4212214	Molla ammortizzatore	Spring	Feder	Ressort
9	4007618	Rullo a gabbia SM-160	Roller SM-160	Rolle SM-160	Rouleau SM-160
9	4007619	Rullo a gabbia SM-185	Roller SM-185	Rolle SM-185	Rouleau SM-185
9	4007620	Rullo a gabbia SM-210	Roller SM-210	Rolle SM-210	Rouleau SM-210
9	4007621	Rullo a gabbia SM-235	Roller SM-235	Rolle SM-235	Rouleau SM-235
10	4007614	Protezione lato esterno	Protection	Schutz	Protection
11	4007612	Braccio registro 19/280	Arm 19/280	Arm 19/280	Bras 19/280
12	6351004	Copiglia a "R" ø 4x80	Split pin "R" ø 4x80	Splint "R" ø 4x80	Coupille "R" ø 4x80
13	34121012	Rondella grower ø 12 UNI 1751	Washer ø 12 UNI 1751	Scheibe ø 12 UNI 1751	Rondelle ø 12 UNI 1751
14	34120012	Rondella piana ø 12 UNI 6592	Washer ø 12 UNI 6592	Scheibe ø 12 UNI 6592	Rondelle ø 12 UNI 6592
15	34100012	Dado M 12 PG UNI 5587	Nut M12 PG UNI 5587	Mutter M12 PG UNI 5587	Ecrou M12 PG UNI 5587
16	4934778	Gancio catena SM-185/210/230	Chain plate SM-185/210/230	Metalplatte SM-185/210/230	Plaque chaîne SM-185/210/230
17	30210010	Vite M10x1,5x10 UNI 5739	Screw M10x1,5x10 UNI 5739	Schraube M10x1,5x10 UNI 5739	Vis M10x1,5x10 UNI 5739
18	4232111	Perno laterale coperchio	Pin	Bolzen	Axe
19	4304003	Perno fissaggio tirante	Pin	Bolzen	Axe
20	34021010	Rondella grower ø 10 UNI 1751	Washer ø 10 UNI 1751	Scheibe ø 10 UNI 1751	Rondelle ø 10 UNI 1751
21	34106014	Dado autobloc. M14 PG alto	Self locking nut M14 PG	Selbstsperrendmutter M14 PG	Ecrou autobloquant M14 PG
22	6560006	Ingrassatore M6x1	Grease nipple M6x1	Schmiernippel M6x1	Graisseur M6x1
23	34000014	Dado M14 PG UNI 5587	Nut M14 PG UNI 5587	Mutter M14 PG UNI 5587	Ecrou M14 PG UNI 5587
24	6330636	Spina elastica	Split pin	Splint	Goupille elastique
25	31514035	Vite M14x2x35 UNI 5739	Screw M14x2x35 UNI 5739	Schraube M14x2x35 UNI 5739	Vis M14x2x35 UNI 5739
26	4007972	Coperchio corto tipo "B" SM-160	Bonnet SM-160	Deckel SM-160	Capot SM-160
26	4007973	Coperchio corto tipo "B" SM-185	Bonnet SM-185	Deckel SM-185	Capot SM-185
26	4007974	Coperchio corto tipo "B" SM-210	Bonnet SM-210	Deckel SM-210	Capot SM-210
27	4007616	Staffa fissaggio rullo	Bracket	Pratze	Bride
28	4594007	Distanziale rullo a gabbia	Spacer	Abstandstück	Entretoise
29	4007622	Telaio rullo SM-160	Frame SM-160	Gestell SM-160	Cadre SM-160
29	4007623	Telaio rullo SM-185	Frame SM-185	Gestell SM-185	Cadre SM-185
29	4007624	Telaio rullo SM-210	Frame SM-210	Gestell SM-210	Cadre SM-210
29	4007625	Telaio rullo SM-235	Frame SM-235	Gestell SM-235	Cadre SM-235
30	30214040	Vite M14x2x40 UNI 5739	Screw M14x2x40 UNI 5739	Schraube M14x2x40 UNI 5739	Vis M14x2x40 UNI 5739
31	2000035	Supporto UCF-207	Support	Halterung	Support
32	4007613	Protezione carter trasmissione	Protection	Schutz	Protection
33	34121014	Rondella grower ø 14 UNI 1751	Washer ø 14 UNI 1751	Scheibe ø 14 UNI 1751	Rondelle ø 14 UNI 1751
34	4002134	Braccio laterale	Arm	Arm	Bras
35	34021014	Rondella grower ø 14 UNI 1751	Washer ø 14 UNI 1751	Scheibe ø 14 UNI 1751	Rondelle ø 14 UNI 1751
36	4007975	Coperchio corto tipo "B" SM-235 Dx	Right cover SM-235	Rechtes deckel SM-235	Couvercle droit SM-235
37	4007976	Coperchio corto tipo "B" SM-235 Sx	Left cover SM-235	Linkes deckel SM-235	Couvercle gauche SM-235
38	4007978	Cop. corto tipo "B" SM-sc-160	Bonnet SM-sc-160	Deckel SM-sc-160	Capot SM-sc-160
39	4232106	Perno coperchio SM-160	Pin SM-160	Bolzen SM-160	Axe SM-160
39	4232107	Perno coperchio SM-185	Pin SM-185	Bolzen SM-185	Axe SM-185
39	4232108	Perno coperchio SM-210	Pin SM-210	Bolzen SM-210	Axe SM-210
39	4237901	Perno coperchio SM-235	Pin SM-235	Bolzen SM-235	Axe SM-235
40	34100014	Dado M14 PG UNI 5587	Nut M14 PG UNI 5587	Mutter M14 PG UNI 5587	Ecrou M14 PG UNI 5587

Type: FRESATRICE

Mod.: RM

Rev.: 00/2011

Tab: 6/6

Pag. 1/1

RIF.	CODICE	DENOMINAZIONE	DESCRIPTION	BENENNUNG	DESIGNATION
1	4007852	Attacco ruotino	Wheel connection	Anschluss Rädchen	Connexion roulette
2	4007854	Supporto ruotino Dx	Support	Halterung	Support
3	4007855	Supporto ruotino Sx	Support	Halterung	Support
4	4838290	Piastra attacco ruotino	Plate	Platte	Plaque
5	31414060	Vite M14x1,5x60 UNI 5738	Screw M14x1,5x60 UNI 5738	Schraube M14x1,5x60 UNI 5738	Vis M14x1,5x60 UNI 5738
6	34121014	Rondella grower ø 14 UNI 1751	Washer ø 14 UNI 1751	Scheibe ø 14 UNI 1751	Rondelle ø 14 UNI 1751
7	34101014	Dado M14 PF UNI 5587	Nut M14 PF UNI 5587	Mutter M14 PF UNI 5587	Ecrou M14 PF UNI 5587
8	6351003	Coppiglia a "R" ø 3x60	Split pin "R" ø 3x60	Splint "R" ø 3x60	Goupille "R" ø 3x60
9	4236115	Perno bloccaggio piedino	Pin	Bolzen	Axe
10	6600052	Coppetta ø 52	Cap ø 52	Abschlusskappe ø 52	Couvercle ø 52
11	34107018	Dado autobloc. M18 PF alto	Self locking nut M18 PF	Nutmutter M18 PF	Ecrou autobloquant M18 PF
12	34120018	Rondella piana ø 18 UNI 6592	Washer ø 18 UNI 6592	Scheibe ø 18 UNI 6592	Rondelle ø 18 UNI 6592
13	2106205	Cuscinetto 6205	Bearing 6205	Lager 6205	Roulement 6205
14	6611280	Ruota ferro 280 x 120 (6205)	Wheel 280 x 120 (6205)	Rad 280 x 120 (6205)	Roue 280 x 120 (6205)
15	2226205	Cuscinetto 6205 2RS	Bearing 6205 2RS	Lager 6205 2RS	Roulement 6205 2RS
16	34018024	Rosetta piana 25x51x5	Washer 25x51x5	Scheibe 25x51x5	Rondelle 25x51x5

DISTRIBUTOR

TRAM SALES LTD.

10757-182 Street
Edmonton, AB T5S 1J5 Canada
Ph: (780) 484-2231; Fx: (780) 484-0817
e-mail: info@tramsales.com
www.tramsales.com

DEALER STAMP

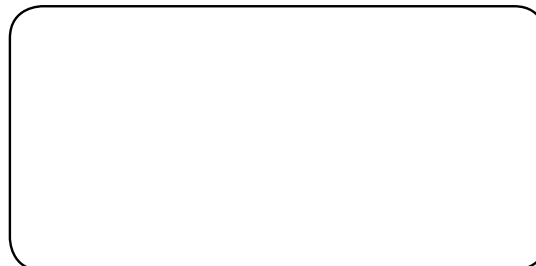

Sicma S.p.A.
66010 Miglianico (CH) Italia
C.da Cerreto