

CE

EN

English

# TILLER SPR

160•185•210•235•260

## USER AND MAINTENANCE MANUAL

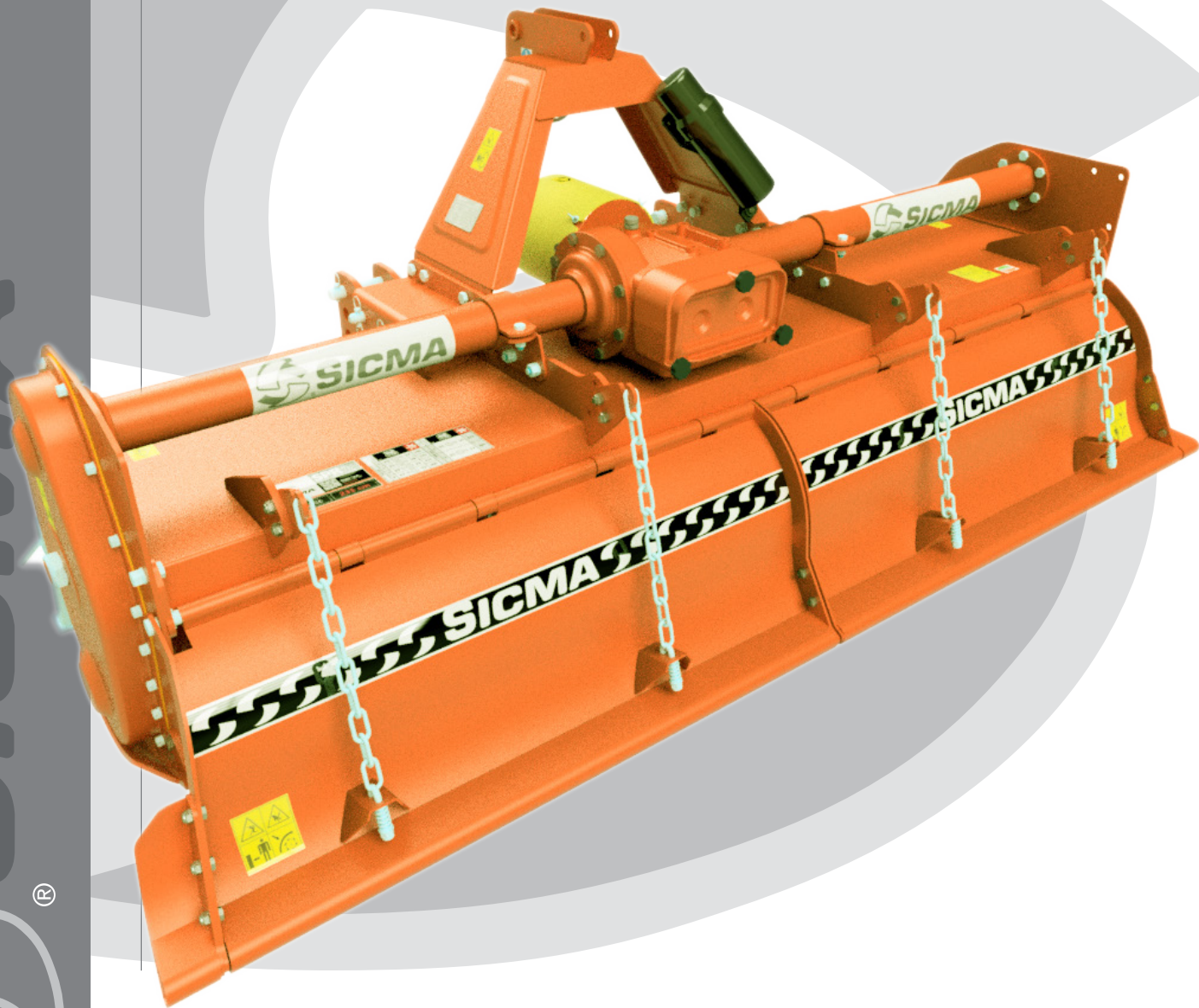

SICMA<sup>®</sup>

ORIGINAL INSTRUCTIONS  
903423006~00

**AURORA**  
GROUP  
FULL MADE IN ITALY



# TABLE OF CONTENTS

<b>1.</b>	<b>INTRODUCTION</b>	<b>5</b>	
1.1	SOME NOTES REGARDING THE USER MANUAL	5	
1.2	DECLARATION OF CONFORMITY	6	
1.3	LIST OF RESIDUAL RISKS	7	
1.4	DELIVERY LETTER	8	
1.5	TILLER IDENTIFICATION AND MANUAL CODE	9	
1.6	INTENDED USE	9	
1.7	GENERAL DELIVERY NOTES	10	
1.8	MAIN PARTS OF THE TILLER	11	
1.9	STANDARD AND OPTIONAL SET-UPS	12	
<b>2.</b>	<b>SAFETY</b>	<b>13</b>	
2.1	DEFINITIONS (UNI EN ISO 12100-1:2009)	13	
2.2	CONVENTIONAL SYMBOLS	13	
2.3	SAFETY PRESCRIPTIONS	14	
2.4	OPERATOR REQUISITES	14	
2.5	CLOTHING AND PPE	14	
2.6	MACHINE USE	15	
2.7	SAFETY DEVICES	15	
2.8	REASONABLY FORSEEABLE MISUSE	15	
2.9	HYDRAULIC PLANT	16	
2.10	ZERO ENERGY STATE	16	
2.11	LOCATION OF PICTOGRAMS AND LABELS	17	
<b>3.</b>	<b>UNLOADING AND UNPACKING THE TILLER</b>	<b>19</b>	
3.1	TILLER PROTECTED BY HEAT-SHRINKABLE FILM	19	
3.2	TILLER IN WOODEN CRATE	20	
<b>4.</b>	<b>TECHNICAL SPECIFICATIONS</b>	<b>22</b>	
<b>5.</b>	<b>START-UP</b>	<b>23</b>	
5.1	3-POINT HITCH CONNECTION	23	
5.2	CARDAN SHAFT CONNECTION	25	
5.3	CHECK THE STABILITY OF THE TRACTOR-TILLER	COMPLEX.	27
5.4	ROAD TRANSPORT	28	
<b>6.</b>	<b>ADJUSTMENTS</b>	<b>28</b>	
6.1	ROTATION SPEED GEAR (ROTOR)	28	
6.2	CLUTCH ADJUSTMENT	29	
6.3	WORK HEIGHT ADJUSTMENT	29	
6.4	REAR BONNET ADJUSTMENT	30	
<b>7.</b>	<b>WORKMANSHIP</b>	<b>31</b>	
7.1	PREVENTIVE MAINTENANCE	31	
7.2	USE	31	
<b>8.</b>	<b>STOPS</b>	<b>32</b>	
<b>9.</b>	<b>ORDINARY MAINTENANCE</b>	<b>34</b>	
9.1	CONTROL AND REPLACEMENT OF	THE OIL IN THE GEARBOX UNIT	35
9.2	CONTROL AND REPLACEMENT OF	THE OIL IN THE LATERAL DRIVE SUMP	37
9.3	CONTROL AND REPLACEMENT OF THE OIL	IN THE EXTERNAL ROTOR LATERAL SUPPORT	38
9.4	REPLACEMENT OF TOOLS HOES/BLADES	38	
<b>10.</b>	<b>CARDAN SHAFT</b>	<b>40</b>	
<b>11.</b>	<b>CLEANING</b>	<b>40</b>	



<b>12.</b>	<b>STORAGE AND WINTERING</b>	<b>40</b>
<b>13.</b>	<b>SCRAPPING</b>	<b>41</b>
<b>14.</b>	<b>QUICK CONSULTATION TABLES</b>	<b>41</b>
14.1	TABLE OF TIGHTENING TORQUES	41
14.2	TROUBLESHOOTING	42
14.3	LUBRICATION INTERVALS	43
<b>15.</b>	<b>SPARE PARTS</b>	<b>44</b>
<b>16.</b>	<b>WARRANTY</b>	<b>44</b>



Congratulations on your purchase of the

## SPR Tiller

The SPR Tiller is manufactured by SICMA S.p.A, which has been producing agricultural machines for over 40 years.

The SPR Tiller has all the safety and quality requisites required for this type of equipment.

Remember that to get the best performance and to maximize the productivity features, you must thoroughly know the instructions and information contained in this manual and follow them.

## 1. INTRODUCTION

### 1.1 SOME NOTES REGARDING THE USER MANUAL

Remember that the USER MANUAL is not an accessory of the Tiller but is an INTEGRAL part and a SAFETY MEASURE (EN 12100-1).

For this reason the following are necessary:

- Keep the manual in a good state;
- It must be kept near to the equipment;
- Pass it on to any operator user, maintenance technician, handler or successive owner.

In this way, the Tiller can be used in the best way for all the functions for which it was manufactured and in maximum safety.

The manual must not be damaged, it must remain integral (do not rip the sheets), it must be kept away from humidity and heat. During consultation it must not be covered in grease or and its legibility must not be impaired.

If this manual is lost or damaged, ask for a copy from the Manufacturer or nearest Dealer.

To facilitate consultation, the manual has been divided into parts so that every phase is well described.

With these measures, SICMA intends to draw unequivocally the operator's attention on the dangerous situations that may arise.



## 1.2 DECLARATION OF CONFORMITY

The machine is delivered accompanied by the following Declaration of Conformity.

### EC DECLARATION OF CONFORMITY

in accordance with Directive 2006/42/CE

The company

Sicma s.p.a. - C.da Cerreto, 39 - 66010 Miglianico (Ch) - Italy  
Tel.: +39 0871 95841 - Fax: +39 0871 950295  
e-mail: info@sicma.it - <http://www.sicma.it>

hereby declares that:

product: TILLER  
model: SPR  
serial number:

complies with the essential requirements for safety and health of Directive 2006/42/CE.

To fulfil the above mentioned Directive have been applied the following harmonised standards:

. UNI EN ISO 12100:2010, UNI EN ISO 4254-1:2022, UNI EN ISO 4254-5:2018, UNI EN ISO 4413:2012,  
UNI EN ISO 13854:2020, UNI EN ISO 13857:2020; UNI EN ISO 14120:2015.

and the technical standards and specifications

- ISO 11684:2023, ISO 13857:2019, ISO 12100:2010, ISO 4254-1:2013/AMD1:2021, ISO 4254-5:2018,  
ISO 4413:2010, ISO 13854:2017

The person authorised to compile the technical file is Mr. Marcello Aurora



Miglianico, 01/08/2020

**Chiara Aurora**  
Administrateur unique



### 1.3 LIST OF RESIDUAL RISKS

Although SICMA has done everything possible to make sure that the machine is in line with the state of art on safety and complies with all directives, laws and regulations, it still exist the possibility, albeit reduced, for some residual risks:

- RISK OF CUTTING/CRUSHING DUE TO CONTACT WITH TOOLS (rotor)
- RISK OF ENTANGLEMENT/Dragging (rotor and drive shaft)
- OVERTURNING/CRUSHING HAZARD (Tiller)
- BURNS HAZARD (gearbox)
- OIL EJECTION HAZARD (hydraulic piping)
- CUT/SHEARING HAZARD (rear covers)

Therefore, those who use the machine or maintain it must be educated persons and aware of the fact that the machine still poses residual risks that, despite all the safety guards used to try to minimize them, it was not possible to eliminate them entirely.

The staff assigned to these operations must always have this available at hand this use and maintenance manual.

The use and maintenance manual reports all the information required by section 1.7.4 (Instructions for Use) of Annex 1 of the Machinery Directive, and its consultation is specifically requested in order to avoid accidents that may cause personal injury.



## 1.4 DELIVERY LETTER

The Tiller was designed in compliance with the Directive 2006/42/EC and was designed observing the guidelines of the technical standards relative to tillers, specifically UNI EN ISO 4254-1:2010 and UNI EN ISO 4254-5:2009.

Therefore, the machine does not represent a danger for the operator if used according to the instructions in this manual and on condition that the safety devices are kept constantly efficient.

This form evidences receipt of the Tiller:

- Do not remove the safety devices
- This manual has been delivered

SICMA COMMUNICATES THAT ANY CHANGES OR ALTERATION TO THE TILLER, OR ANY OPERATION PERFORMED AND NOT STRICTLY REPORTED IN THIS MANUAL, ESPECIALLY NON-COMPLIANCE WITH THE SAFETY INSTRUCTIONS, NOT ONLY VOID THE WARRANTY BUT ALSO EXEMPT SICMA FROM ANY RESPONSIBILITY FOR DAMAGE TO PROPERTY AND PERSONS.

Some devices described in the manual may not be present on your machine due to the arrangement chosen and the market for which the machine is intended.

It should be remembered that all the technical values refer to the standard Tiller (see Section 4 "Specifications") and that the drawings and any other document delivered with the Tiller are the property of SICMA, which reserves all rights and points out that they cannot be made available to any third party without its written approval.

Therefore, any reproduction, even partial, of the text and illustrations is prohibited.

The information, descriptions and illustrations contained in this manual reflect the state of the art of the machine at the moment it was put on the market.

The Manufacturer reserves the right to make, at any time, any changes to the machines for technical or commercial reasons. These changes do not require the Manufacturer to act on vehicles sold so far, nor to consider the present publication inadequate.

Any additions that the Manufacturer deems appropriate to provide later, will need to be kept with the manual and considered to be part of it.

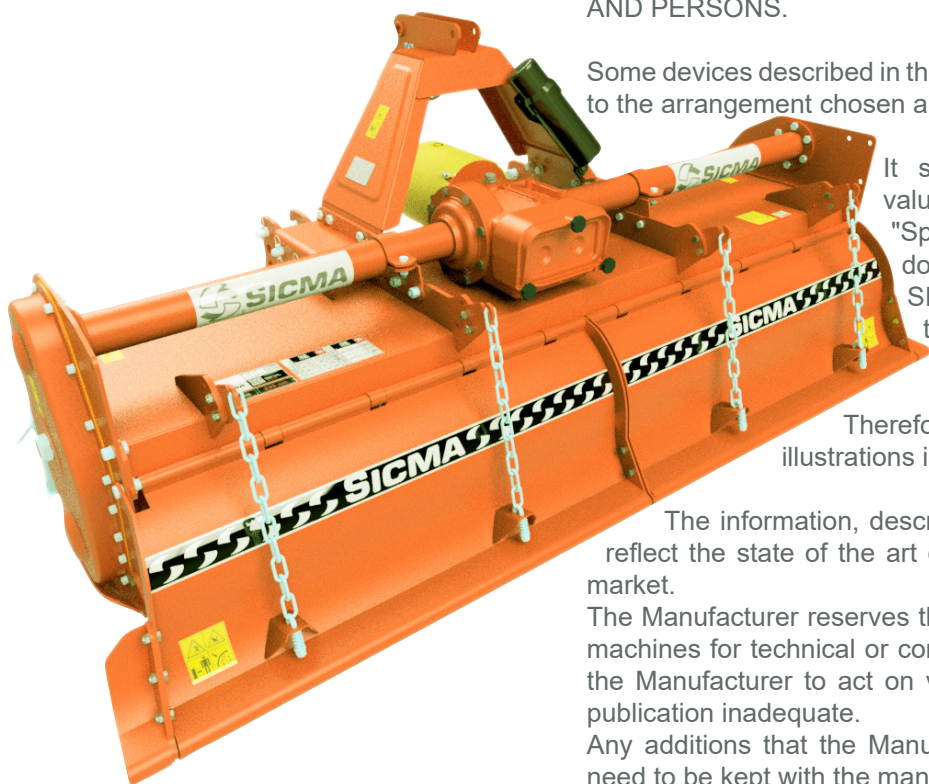



# TILLER SPR

160•185•210•235•260

USER AND MAINTENANCE MANUAL

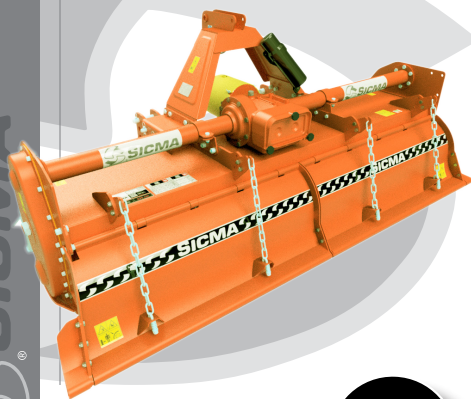

ORIGINAL INSTRUCTION  
903423006-00



AURORA  
FULL MADE IN ITALY



SICMA SPA - C.da Cerreto, 39 - 66100 Miglianico (Ch) - Italy  
Tel.: +39 0871 95841 Fax: +39 0871 950295 - info@sicma.it - www.sicma.it



Type	Tiller
Model	SPR 185
Serial No	00561
Year	2017
Mass	610 Kg
Input	540 rpm

MADE IN ITALY

## 1.5 TILLER IDENTIFICATION AND MANUAL CODE

For any after-sales requests or information regarding the Tiller, contact SICMA or its after-sales centres always stating the model and the serial number stated on the plate.

The identification code of this manual is indicated on the cover. Write the number in a different safe place so that if this manual is lost or damaged, another copy can be requested from SICMA or from the nearest dealer by also stating the serial number visible in the marking.

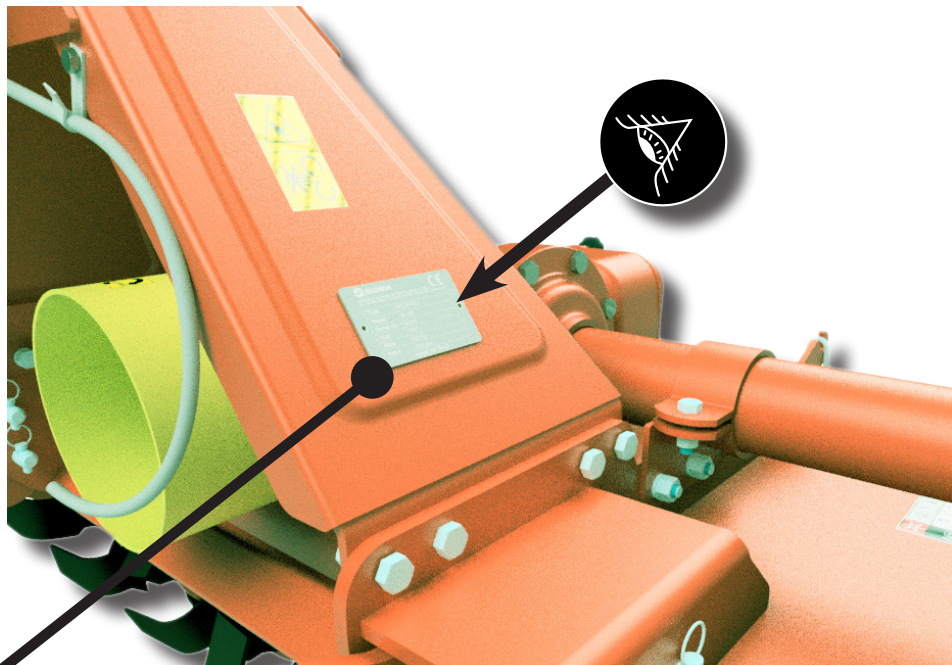

## 1.6 INTENDED USE

The SPR Tiller was expressly designed to work land and was developed with the sole purpose of loosening, turning and oxygenating the land in order to prepare it for sowing.

It was built to be combined with tractors that can withstand its weight, equipped with a hydraulic lift with universal 3-point hitch.

Its drive must be implemented by means of the power take-off (PTO) of the tractor via cardan shaft.

### USE ENVIRONMENT

The Tiller works:

- in open fields, on land that is non friable, not excessively stony and with a maximum gradient of 3°.
- In environments with a temperature from 0° ÷ 50°C.

### IMPROPER USE

Any use different to that declared is to be considered improper.

### REASONABLY FORSEEABLE MISUSE

At times the Tiller may be used improperly.

Here are some examples of actions that **MUST BE AVOIDED AT ALL COSTS**.

The operator must not:

- Use a cardan shaft with unsuitable transmission capacity.
- work in reverse gear compressing the earth with hood press.
- Couple the Tiller to vehicles of unsuitable power or weight.



1



- Assemble the Tiller without securing the rebound tie rods of the three-point hitch of the tractor's elevator.
- Operate the hydraulic lift of the tractor when the equipment is in operation with the PTO engaged.
- Perform steering or reversing with the Tiller during operation.

Remember that the Tiller was designed only for the purpose of declared use. Any other use is to be considered improper.

## 1.7 GENERAL DELIVERY NOTES

The Tiller and its parts and/or accessories are normally delivered by lorry or container.

On receiving the machine check that the delivery corresponds to the order specifications (see delivery note or packing list) and that there is no damage to the Tiller or to the accessories.

In the event of damage or missing pieces, inform SICMA or its area representatives, the carrier or its insurance company immediately possibly providing photos.

The spare parts or equipment supplied are sometimes in separate containers.

The machine is delivered by SICMA equipped with the following supplies:

- 1 - UNIVERSAL JOINT
- 2 - TILLER USE AND MAINTENANCE MANUAL
- 3 - CARDAN SHAFT USE AND MAINTENANCE MANUAL
- 4 - CE DECLARATION OF CONFORMITY



4

**EC DECLARATION OF CONFORMITY**  
in accordance with Directive 2006/42/CE

The company  
Sicma s.p.a. - C.da Cerreto, 39 - 66010 Miglianico (Ch) - Italy  
Tel.: +39 0871 95341 - Fax: +39 0871 955295  
e-mail: info@sicma.it - http://www.sicma.it

hereby declares that:

product: TILLER  
model: SPR  
serial number:

complies with the essential requirements for safety and health of Directive 2006/42/CE.

To fulfil the above mentioned Directive have been applied the following harmonised standards:  
- UNI EN ISO 12100:2010, UNI EN ISO 4254-1:2022, UNI EN ISO 4254-5:2018, UNI EN ISO 4413:2012,  
UNI EN ISO 13854:2020, UNI EN ISO 13857:2020, UNI EN ISO 14120:2015.

and the technical standards and specifications  
- ISO 11684:2023, ISO 13857:2019, ISO 12100:2010, ISO 4254-1:2013/AMD1:2021, ISO 4254-5:2018,  
ISO 4413:2010, ISO 13854:2017

The person authorised to compile the technical file is Mr. Marcello Aurora

Miglianico, 01/08/2020  
**Chiara Aurora**  
Administrateur unique  
*Chiara Aurora*



## 1.8 MAIN PARTS OF THE TILLER

No.	Description
1	Body
2	Lower 3-point hitch
3	Upper 3-point hitch
4	Cardan shaft protection
5	Mast hitch
6	Hoe rotor
7	Blade
8	Sled
9	Gear drive guard
10	Rear hood
11	Reduction group with manual speed gear
12	Outrigger

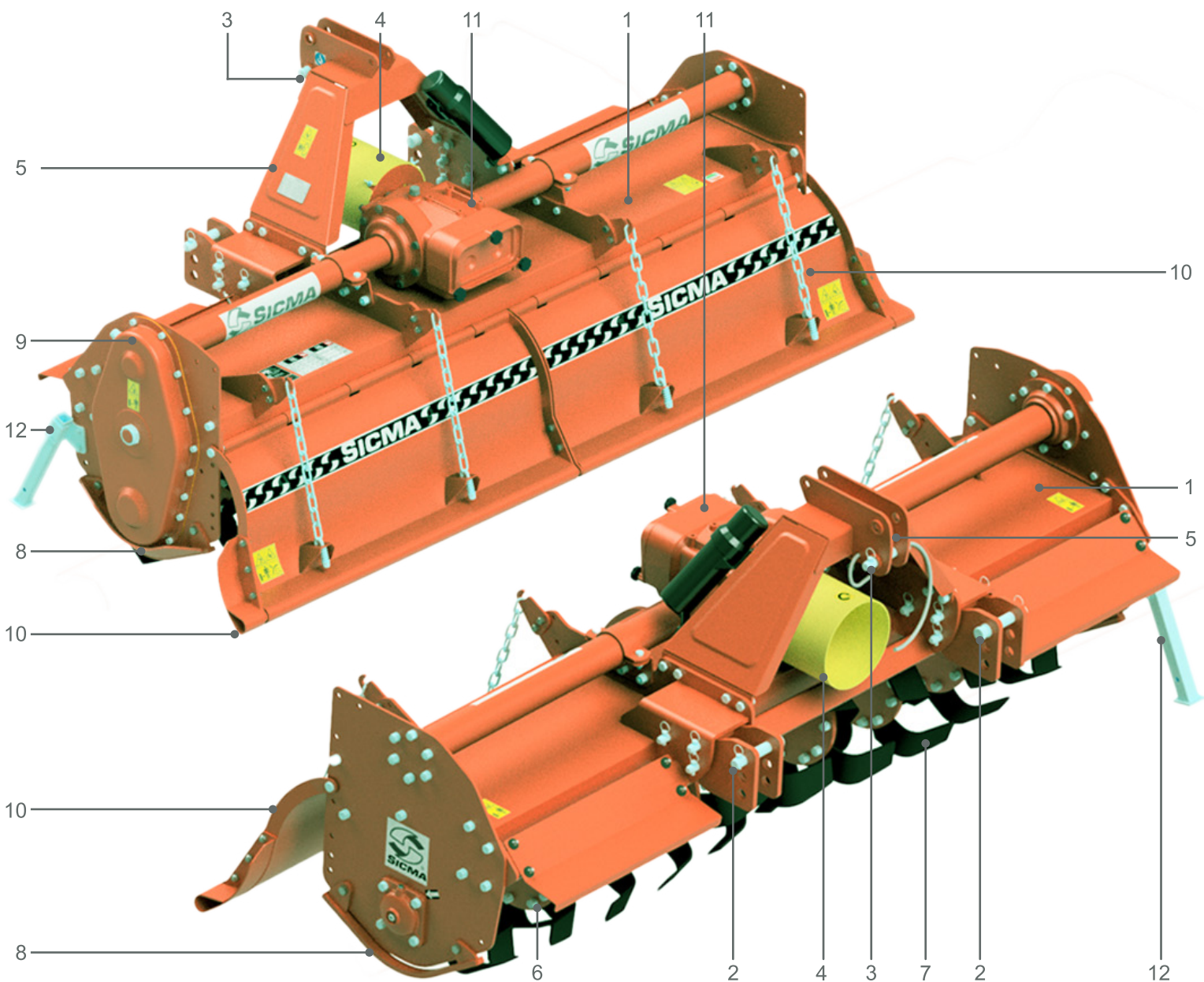

## 1.9 STANDARD AND OPTIONAL SET-UPS

### Standard equipment

- Standard rotor with 6 propeller mounted flange hoes (end hoes pointing outwards).
- Reducer manufactured by SICMA, with tapered roller bearings, 4 (@540 rpm) + 2 (@1000 rpm) speeds with oil level dip stick.
- EC accident prevention.





### Additional options

- Spiked roller.
- Cage roller.
- Packer roller.
- Smooth roller.
- Coil roller.
- Hydraulic system with jacks for roller adjustment.
- Levelling bar
- Iron rear wheels.
- Harrow conveyor discs.
- Reinforcement counter-flanges on the hoes.
- Bonnet presses kit

### Replacement options

- Configuration for PTO 1000 rpm (2 speed: 215-265 rotor revolutions/min)
- Htite® Hoes
- Rotor with 3-hole blades
- Rotor with quick-coupling teeth
- Rotor with end hoes turned inwards

### Type of tools

A	B	C	D	D
				
Curved hoe	Curved hoe with curve adjustment	Square hoe	3-hole blade	Quick coupling tooth
Standard	Optional			

## 2. SAFETY

In this user manual and on the equipment itself, you'll find a few symbols whose meaning is explained below.

### 2.1 DEFINITIONS (UNI EN ISO 12100-1:2009)

#### DANGER:

A potential source of physical injury or damage to health.

#### DANGEROUS AREA:

Any area within and/or in proximity of a machine in which the presence of a person constitutes a risk for the safety and health of the same.

The dangerous area is the area around the machine (attached to the tractor) up to a distance of 1 metre.

#### EXPOSED PERSON:

any person that is found wholly or partly in a dangerous area.

#### CRITICAL AREA:

The critical area is that between the tractor and the equipment (Cardan shaft area).

### 2.2 CONVENTIONAL SYMBOLS



#### ATTENTION:

Informs the staff assigned that the operation described has the risk of physical injury if not performed with respect to the Safety Standards.



#### NOTE:

Informs the staff assigned of information whose content is of relevant consideration and importance.



#### WARNING:

Informs the staff assigned of information whose content can cause slight injury to persons or damage to the machine if not respected.



#### MACHINE OPERATOR OR DRIVER

Identifies the qualified staff, i.e. with specific skills, as the operations are completely manual. Therefore, the preparation and sensitivity of the machine operator are referred to in order to obtain the best qualitative results. The operator is therefore strictly forbidden from performing tasks that should be performed by the maintenance technician.



#### MECHANICAL MAINTENANCE TECHNICIAN:

Qualified technician who works on mechanical components to carry out all the adjustments, maintenance operations and repairs necessary.



#### UNSCHEDULED OPERATIONS:

Any maintenance interventions highlighted by the symbol on the side must be requested to the Manufacturer or directly to authorized service centres.

#### PERSONAL PROTECTION EQUIPMENT (PPE):

The presence of one of the symbols on the side requires the use of appropriate personal protective equipment by the operator, the risk of injury being implicit.





## RECOMMENDATION

It refers to a work mode tried out in the field, aware that every operator will develop their own way of operating.



## 2.3 SAFETY PRESCRIPTIONS

Despite SICMA having applied all the safety devices and warning signs on the equipment, it must be recalled that, if not used correctly, the machine can still be hazardous to health. It is therefore recommended to carefully read and observe the safety instructions listed below.

Any operator, before using the equipment, categorically **MUST** have read and understood the safety instructions and the entire manual.

- The machine is not suitable for use in sectors other than in agriculture.
- A use other than that specified is to be considered improper.
- The manual must be always at hand, so that it is easy for future reference. If it were lost or damaged, you must apply to SICMA for a replacement copy.
- For no reason climb, seat or lean on the equipment whether it is ON, OFF or in zero energy state.

## 2.4 OPERATOR REQUISITES

- The machine must be used by a single operator driving the tractor.
- The machine must only be used by authorised personnel, educated and properly trained. The operator, in addition to having read and understood the instructions contained in this manual, must have gained a sufficient preparation on the proper use of the machine and must be in possession of a driving license. We remind the operator to contact the retailer or the manufacturer if they are unsure about the use of the machine and the interpretation of this manual.
- The operator must ensure that during operation of the machine no person is standing within its range of action. Never operate the machine near people standing or passing within the operating range of the machine.
- Do not use the machine when tired, ill or under the influence of alcohol, medication or drugs.
- The correct operator position is in the tractor driving seat. From this position he must also control that there are no persons exposed in the dangerous area in the work phase.



## 2.5 CLOTHING AND PPE

Staff must use the safety supplies and PPE during use and maintenance of the vehicle.

The correct clothing to be worn during maintenance operations and use of the Tiller is:

- Gloves.
- Accident-prevention shoes or boots with steel toe-cap.
- Goggles.
- Overalls with elasticated wrists, ankles and waist.

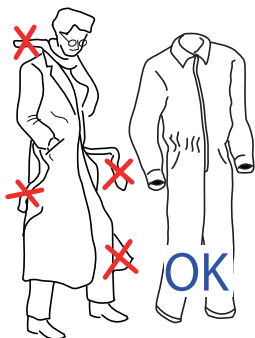

Furthermore:

- Given that the machine can generate emissions of dust during working, if the tractor does not have a closed cab, the operator must wear an anti-dust mask (especially on dry and dusty land)
- When the tractor is not equipped with sound-proof booth, the operator should wear hearing protection for noise control (especially on stony ground).
- The operator assigned to the machine must not wear items of clothing that can cause entanglement (scarves, belts, wide sleeves, etc.).



## 2.6 MACHINE USE

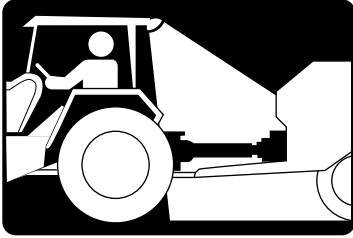

- The machine is usually used during the day. If night-time use is exceptionally required or use in conditions of reduced visibility, a tractor lighting system or an auxiliary lighting system must be used.
- Any unauthorized modification to this machine raises SICMA from any liability for damage or injury that may result to operators, third parties and properties.
- Carefully check the machine before each use.
- Daily check the tightness of all the screws (see the tightness table in section 14.1), tighten them if necessary and also check the metal structure; make any repairs required.
- Make sure that the hooks of the chains retaining the PTO shaft guard are hooked to the appropriate slot, so that the plastic guard remains fixed and does not rotate with the cardan shaft itself.
- Before getting out of the tractor and before every maintenance operation, engage the parking brake, switch off the engine, remove the ignition key from the dashboard and keep it in a safe place.
- When the machine is in operation, the blades are rotating rapidly: remain at a safe distance to prevent accidental contact with moving utensils or from being hit by any projected objects.

## 2.7 SAFETY DEVICES

- Before using the machine, make sure that all safety devices are properly in place and in good condition. If there are failures or damage to the guards, replace them immediately.
- Do not tamper with or bypass for any reason the safety devices. After every cleaning and maintenance intervention, all of the safety devices must be restored and/or all protection housings closed. Also verify that there are no tools, rags or other materials inside the transmission compartments.
- The signs applied to the machine provide a number of important indications: their observance is a guarantee of your safety.
- Ensure the good condition of the safety pictograms. If pictograms are damaged, they must be replaced with other original ones requested from the manufacturer and placed in the position indicated by the use and maintenance manual. 2.11).

## 2.8 REASONABLY FORSEEABLE MISUSE

The operator must not:

- Connect the Tiller to a Cardan shaft with higher or lower power.
- Work in reverse gear compressing the earth with hood press.
- Make changes to equipment that could compromise safety.
- Perform make-shift repairs in order to be able to start work.

In addition, it is prohibited:

- To couple the Tiller to vehicles of unsuitable power or weight.
- To assemble the equipment without having locked the tie rods to prevent shaking to the three-point hitch of the tractor.
- Lift the equipment with the PTO rotating
- Tamper with the hydraulic systems (if any).
- Use the machine to carry and/or lift persons, animals or objects.
- Work on slopes greater than 3°.

Sicma declines any liability for accidents deriving from the failure to comply with the prescriptions indicated above.

Given the particular stress to which the equipment is subjected and for safety reasons, if pieces are replaced, only use original spare parts.

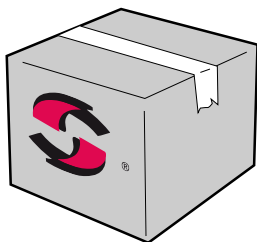

## 2.9 HYDRAULIC PLANT

If there is a hydraulic system, check the good condition of the hydraulic pipes daily and, if necessary, replace them as described in para. 9 "Routine maintenance".



### ATTENTION CONTAMINATION HAZARD!

The operator must pay attention to oil leaks and perform relative repairs immediately. Moreover, oil must not be poured onto the ground when topping-up or replacing the oil.

Also check the fittings and their correct connection before pressurising the hydraulic lines.

Before performing interventions on the pressurised hydraulic lines, make sure that the line has been de-pressurised and does not still contain hot fluid.

The machine must not be left unattended when the tractor is in motion.

The ignition keys must always be in the possession of the operator and must never remain inserted in the dashboard in their absence.

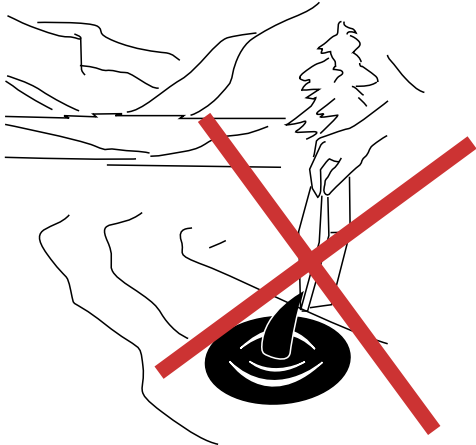

## 2.10 ZERO ENERGY STATE

The "zero energy state" is defined as the state in which the Tiller is to be taken before performing any cleaning, lubrication and maintenance operation.

Perform the following operations to take the Tiller to the "zero energy state":

- Position the Tiller on stable, flat land with a maximum gradient of 3°.
- Disable the PTO from the tractor.
- Engage the tractor hand brake
- Turn off the tractor, remove the key and keep it in your pocket.
- Get off the tractor and disconnect the cardan shaft from the PTO of the tractor.
- Disconnect the hydraulic points
- Position the outrigger in the stop position
- Disconnect the 3-point hitch.

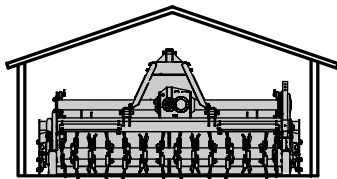
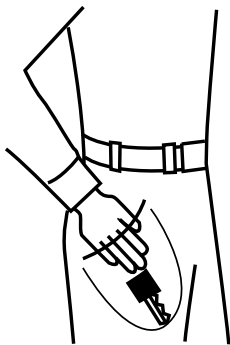

## 2.11 LOCATION OF PICTOGRAMS AND LABELS

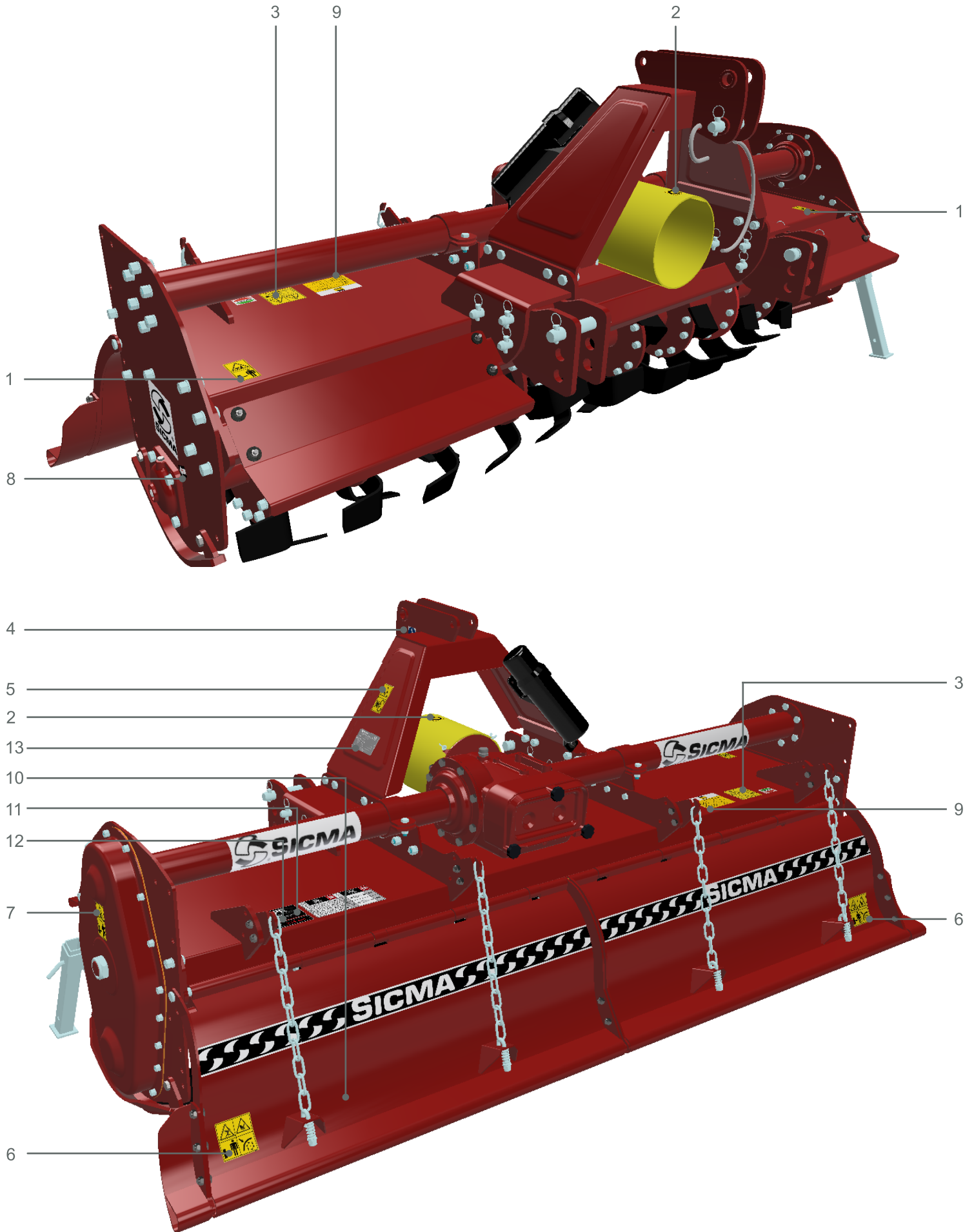

















## DESCRIPTION OF PICTOGRAMS AND LABELS

For the purposes of the Tiller's physical safety and efficiency, it is important to keep all the stickers in perfect condition.

When one or more stickers are difficult to read or in fact absent, arrange immediate purchase by contacting SICMA or the nearest dealer.

The following table lists the safety stickers with the relevant codes. The latter may be communicated to the dealer for possible purchase.

Ref.	STICKER	DESCRIPTION	CODE
1		<b>Foot injury hazard.</b> Rotating tools: maintain a safe distance from the machine.	4781011
2		<b>Input 540 rpm.</b> Possibility of use of a 540 rpm power take-off.	4781010
3		<b>Input 1000 rpm.</b> Possibility of use of a 1000 rpm power take-off.	4781030
3		<b>But also be careful.</b> Carefully read the instructions and safety precautions before using the machine. Switch off the engine and remove the key before carrying out maintenance or repairs.	4781029
4		<b>Hook</b> Point useful for attachment of the lifting hook	4781031
5		<b>Hand injury hazard</b> Keep safety guards in place during operation	4781013
6		<b>Thrown objects on entire body</b> Keep a safe distance from the machine. Risk of injury to the hands: do not open or remove the safety guards while the machine is in motion.	4781019
7		<b>Foot injury hazard.</b> Sharp objects: maintain a safe distance from the machine.	4781012
8		<b>OIL.</b> Indication of lubrication oil load point.	4781008

9	 <table border="1"> <tr> <th colspan="2">usare esclusivamente use only user exclusivement</th> </tr> <tr> <td>olio idraulico hydraulic oil huile hydraulique</td> <td>OSO 15-32-46-68</td> </tr> <tr> <td>riduttore gear oil huile pour engranages</td> <td>Blasia 150</td> </tr> <tr> <td>lubrificazione a grasso grease lubrication graissage</td> <td>Grease MU EP 2</td> </tr> </table>	usare esclusivamente use only user exclusivement		olio idraulico hydraulic oil huile hydraulique	OSO 15-32-46-68	riduttore gear oil huile pour engranages	Blasia 150	lubrificazione a grasso grease lubrication graissage	Grease MU EP 2	<b>OIL types</b> Use only ENI oils	4781099																			
usare esclusivamente use only user exclusivement																														
olio idraulico hydraulic oil huile hydraulique	OSO 15-32-46-68																													
riduttore gear oil huile pour engranages	Blasia 150																													
lubrificazione a grasso grease lubrication graissage	Grease MU EP 2																													
10	<table border="1"> <tr> <th rowspan="2">PTO</th> <th colspan="4">SPEED</th> </tr> <tr> <th>1</th> <th>2</th> <th>3</th> <th>4</th> </tr> <tr> <td rowspan="2">540 rpm</td> <td>23</td> <td>17</td> <td>145</td> <td></td> </tr> <tr> <td>21</td> <td>19</td> <td>175</td> <td></td> </tr> <tr> <td rowspan="2">1000 rpm</td> <td>19</td> <td>21</td> <td>215</td> <td></td> </tr> <tr> <td>17</td> <td>23</td> <td>260</td> <td></td> </tr> </table>	PTO	SPEED				1	2	3	4	540 rpm	23	17	145		21	19	175		1000 rpm	19	21	215		17	23	260		<b>Gear info</b> Follow the instructions for correct use of the gearbox	4784503
PTO	SPEED																													
	1	2	3	4																										
540 rpm	23	17	145																											
	21	19	175																											
1000 rpm	19	21	215																											
	17	23	260																											
11	 	<b>Machine info</b> Machine abbreviation (SPR)	4784201																											
12	 	<b>Width information</b> Machine width (235cm)	000-235																											
13	  <table border="1"> <tr> <td>Type</td> <td>FRESATRICE</td> </tr> <tr> <td>Model</td> <td>SPR 235</td> </tr> <tr> <td>Serial No</td> <td>00216</td> </tr> <tr> <td>Year</td> <td>2016</td> </tr> <tr> <td>Mass</td> <td>720 Kg</td> </tr> <tr> <td>Input</td> <td>540 rpm</td> </tr> </table>	Type	FRESATRICE	Model	SPR 235	Serial No	00216	Year	2016	Mass	720 Kg	Input	540 rpm	<b>CE plate</b> Stating the main data with serial number and CE mark.	4780001															
Type	FRESATRICE																													
Model	SPR 235																													
Serial No	00216																													
Year	2016																													
Mass	720 Kg																													
Input	540 rpm																													

### 3. UNLOADING AND UNPACKING THE TILLER



#### ATTENTION CRUSHING HAZARD!

Qualified staff that have read and understood the safety prescriptions must unload the Tiller from the lorry and handle the equipment in the work place.



A person in charge of operations must always be present during loading and unloading. In all cases, make sure that there are no persons, animals or objects in the unload area and behave as described in this manual.

The Tiller is normally transported on a lorry, sometimes without packaging, sometimes protected by heat shrinkable film and other times in wooden crates.



#### ATTENTION!

Read and understand the "Safety prescriptions" part before starting to transport and unpack the Tiller.



#### 3.1 TILLER PROTECTED BY HEAT-SHRINKABLE FILM

##### NOTE

Before proceeding with unloading of the truck read this entire sequence to be prepared in time for unexpected events.

Release the Tiller from any fixing devices used to fasten it to the means of transport.



#### ATTENTION: DANGER OF CRUSHING AND ENTRAPMENT!

Unloading of the Tiller must be performed very slowly, and the operator must ensure that there are no persons, animals and objects in the unloading zone.



#### ATTENTION: CRUSHING AND ENTRAPMENT HAZARD!

Before lifting:

- ensure the good condition of the ropes or chains used to lift the machine.
- Make sure the cables/chains are of sufficient capacity. Bear in mind that every single rope/chain must be able to lift the weight of the Tiller (see "Specifications" in section 4 "Specifications")
- Make sure that the shackles are tight;
- In the case of chains with shorteners, make sure that they are securely connected too.

After securing the Tiller with ropes or chains, raise the equipment by a few centimetres to check that it is properly balanced; otherwise gently reposition the Tiller on the truck bed, adjust the length of the ropes/chains and attempt the operation again.

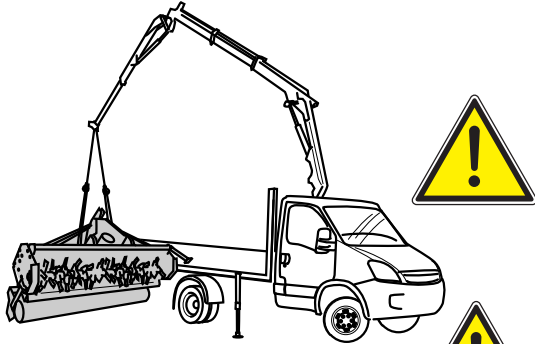

**ATTENTION: CRUSHING AND ENTRAPMENT HAZARD!**

Lift the Tiller from the deck of the means of transport to a height of approximately 30 cm., unless obstacles are present, so that it does not swing. Position the Tiller on the ground in proximity of the tractor.

Once on the ground remove the chains or ropes and proceed with unpacking of the equipment as described below.



**ATTENTION CUTTING HAZARD!**

In the case in which the Tiller is delivered wrapped in a protective film, remove it with a suitable cutter; be careful not to injure yourself or to damage the actual Tiller.

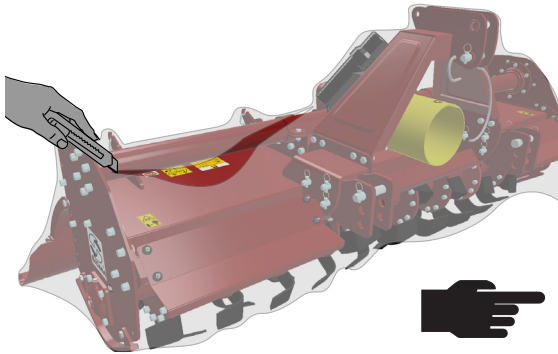

**ATTENTION DANGER OF CONTAMINATION!**

After unpacking do not disperse the packaging into the environment but contact authorised centres for disposal. Check the transport document or packing list supplied and, if necessary, act as described in section 1.7 "General notes on delivery".

**3.2 TILLER IN WOODEN CRATE**

**NOTE**

Before proceeding with unloading of the truck read this entire sequence to be prepared in time for any unexpected events.

If the Tiller is contained inside a wooden crate, use a forklift truck with suitable capacity to unload it (consult section 4 "Specifications" to check the Tiller weight) or use the lorry's lifting arm.



**ATTENTION CRUSHING AND TIPPING HAZARD!**

Unloading of the Tiller must be performed very slowly, and the operator must ensure that there are no persons, animals and objects in the unloading zone.

Insert the forklift forks as indicated in the figure.

Lift the crate from the deck of the means of transport to a height of about 30 cm. unless obstacles are present.

Place the crate on the ground in the vicinity of the tractor.

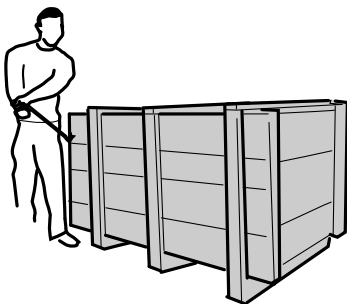

Wear gloves and using a suitable tool, remove the cover from the wooden case. After having secured the Tiller with the ropes and/or chains, lift the equipment by a few centimetres to check whether it is being lifted in a balanced mode otherwise reposition the Tiller and adjust the length of the ropes/chains.

Use ropes/chains of adequate capacity to lift the Tiller (see chapter 4 "Technical specifications" for the weight of the Tiller).



**ATTENTION: CRUSHING AND ENTRAPMENT HAZARD!**

Lift the Tiller a max. of 30 cm from the crate and position it near to the tractor.



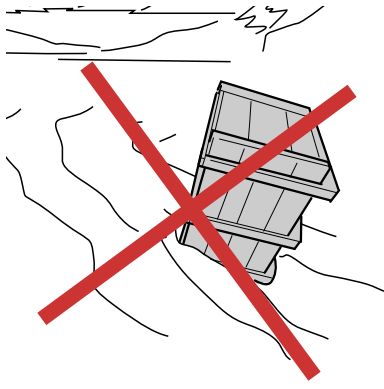

#### ATTENTION CONTAMINATION HAZARD!

After unpacking do not disperse the packaging into the environment but keep it for other transportation and contact authorised centres for disposal. Check the transport document or packing-list supplied and, if necessary, act as described in chapter 1 "General Delivery Notes".



#### ATTENTION TIPPING HAZARD!

During subsequent transportation remember that, even if it is stable, the equipment must ALWAYS:

- Be well secured to the lorry, paying attention not to crush any hydraulic pipes;
- be positioned in the centre of the lorry and not at the edges. In this way, overturning dangers are prevented, due to curves or uneven roads.

## 4. TECHNICAL SPECIFICATIONS

The table below shows the key specifications of the SPR Tiller.

			SPR 160	SPR 185	SPR 210	SPR 235	SPR 260	
Full-size design	Work width		1600	1850	2100	2350	2600	
	Overall width (A)		1910	2160	2410	2660	2910	
	Total height (B)							
	Total length (C)							
	Minimum tractor power		CV	70	70	70	70	70
			Kw	51	51	51	51	51
	Tractor hitch category		Cat	2°	2°	2°	2°	2°
	PTO speed		rpm	540/1000	540/1000	540/1000	540/1000	540/1000
Rotor	Number of rotor revs (540rpm)		Revs/min	1°=142.5 / 2°=174 / 3°=212 / 4°=260				
	Number of rotor revs (1000rpm)		Revs/min	1°=214 / 2°=264				
	Rotor pipe diameter		mm	101.6	101.6	101.6	101.6	101.6
	Rotor pipe thickness		mm	8	8	8	8	8
	Rotor work diameter		mm	525	525	525	525	525
	Type of hoes		Curved hoes	yes	yes	yes	yes	yes
			Square hoes	yes	yes	yes	yes	yes
			3-hole blade	yes	yes	yes	yes	yes
			One-hole tooth	no	no	yes	yes	yes
	Number of hoes		4 hoes/flange	24	28	32	36	40
6 hoes/flange			36	42	48	54	60	
3-hole blade			36	44	52	56	64	
One-hole tooth			-	-	39	44	49	
Weight	Standard version		kg	560	610	660	720	770
			lbs	1232	1342	1452	1584	1694
Noise level	No-load noise detection	Acoustic pressure level	LpAm (A) dB	87.2				
			LwA (A) dB	99.8				

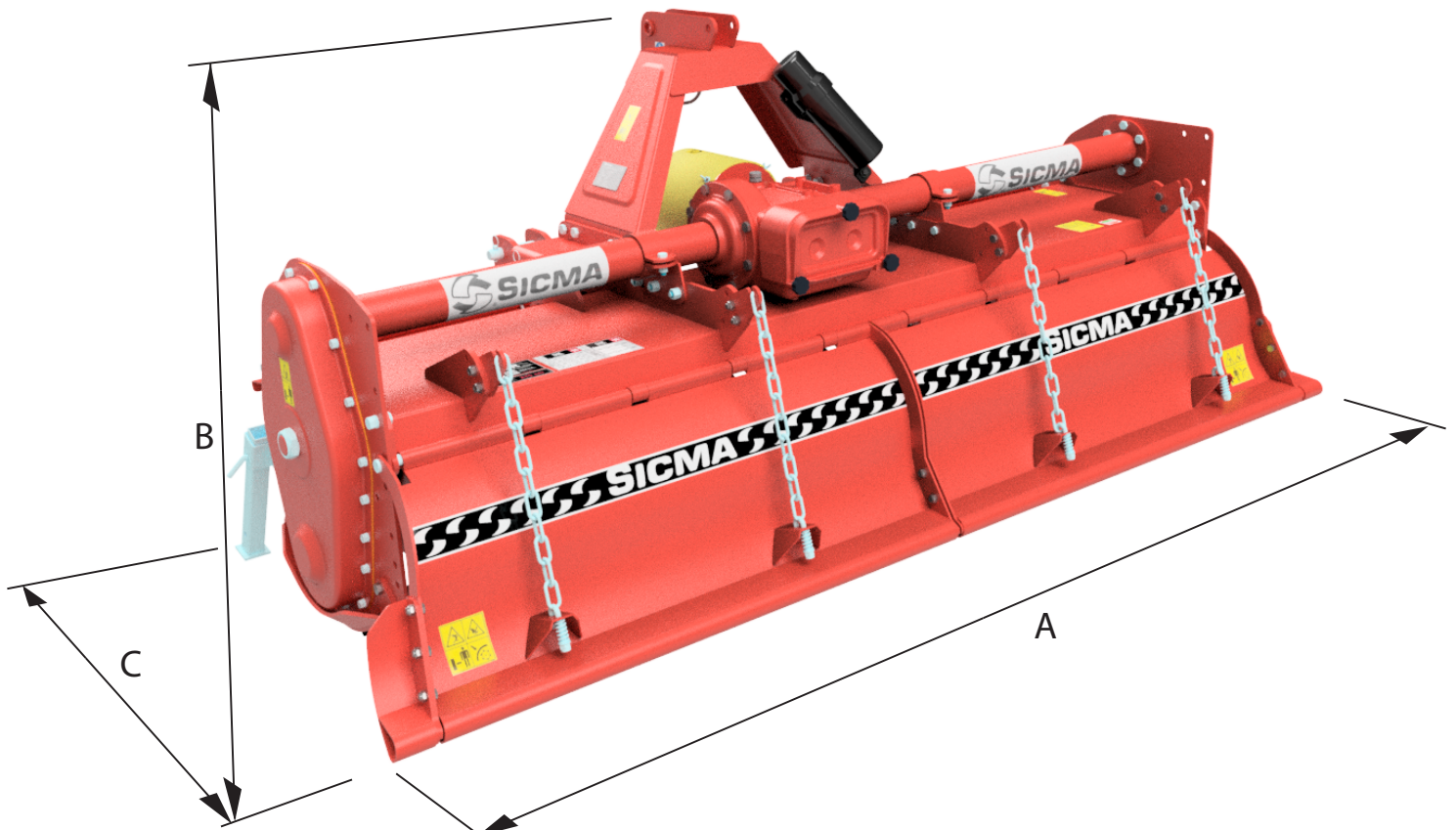

## 5. START-UP



### ATTENTION INJURY HAZARD!

Only qualified operators having read and understood the safety instructions can perform the operations described below. Moreover, they must check that there are no persons, animals and objects exposed in the area where the connection is made to the tractor.

Before performing "set-up - connecting to the tractor" read all of this part to be prepared in time for any event.

The operator and any aids must have PPE available and wear them as required.

The Tiller may only be moved when connected to the tractor.

For the tractor coupling procedures follow step by step the instructions below in the order listed.

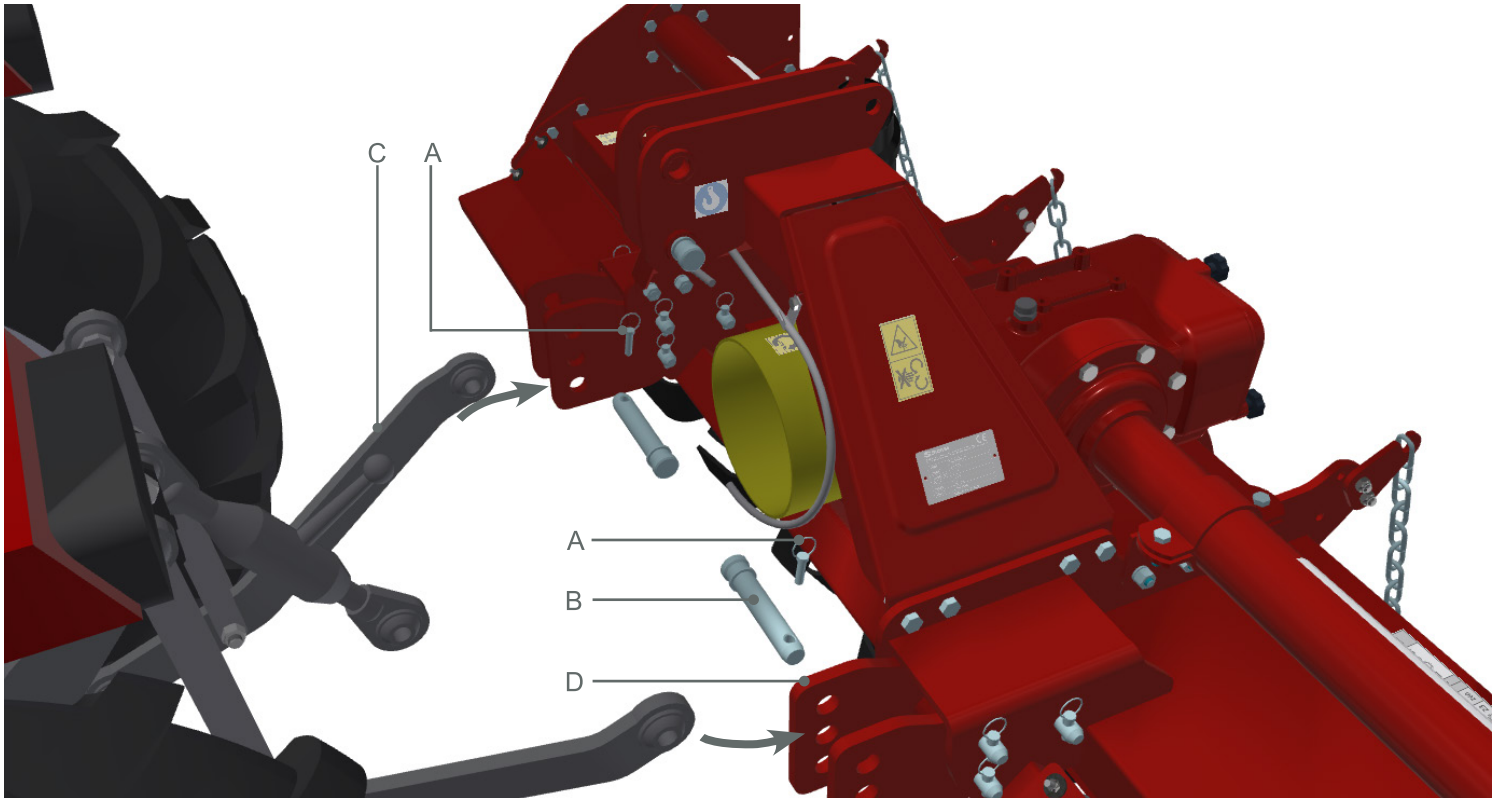

To connect the machine to the tractor, the operator must:

- Remove the split pins "A" of the bolts "B";
- Slide out the pins "B";
- Sit in the driver's seat of the tractor and start the engine.
- Via the tractor commands release the parking brake;
- Reverse slowly until the tractor lifting arm articulation "C" connects with the lower three-point hitch of the Tiller "D";
- Switch the engine off, engage the hand brake, remove the key and keep it in a safe place; then climb down from the tractor;
- Insert the pin into the hole of the lower third point "D" of the Tiller and into the hole of the tractor arm articulation "C".
- Reinsert its safety split pin "A";
- Do the same with the lower attachment opposite;
- lock the anti-shock tie rods of the lifting arms of the tractor to prevent the machine from oscillating laterally, compromising the transverse stability of the tractor/tiller unit.

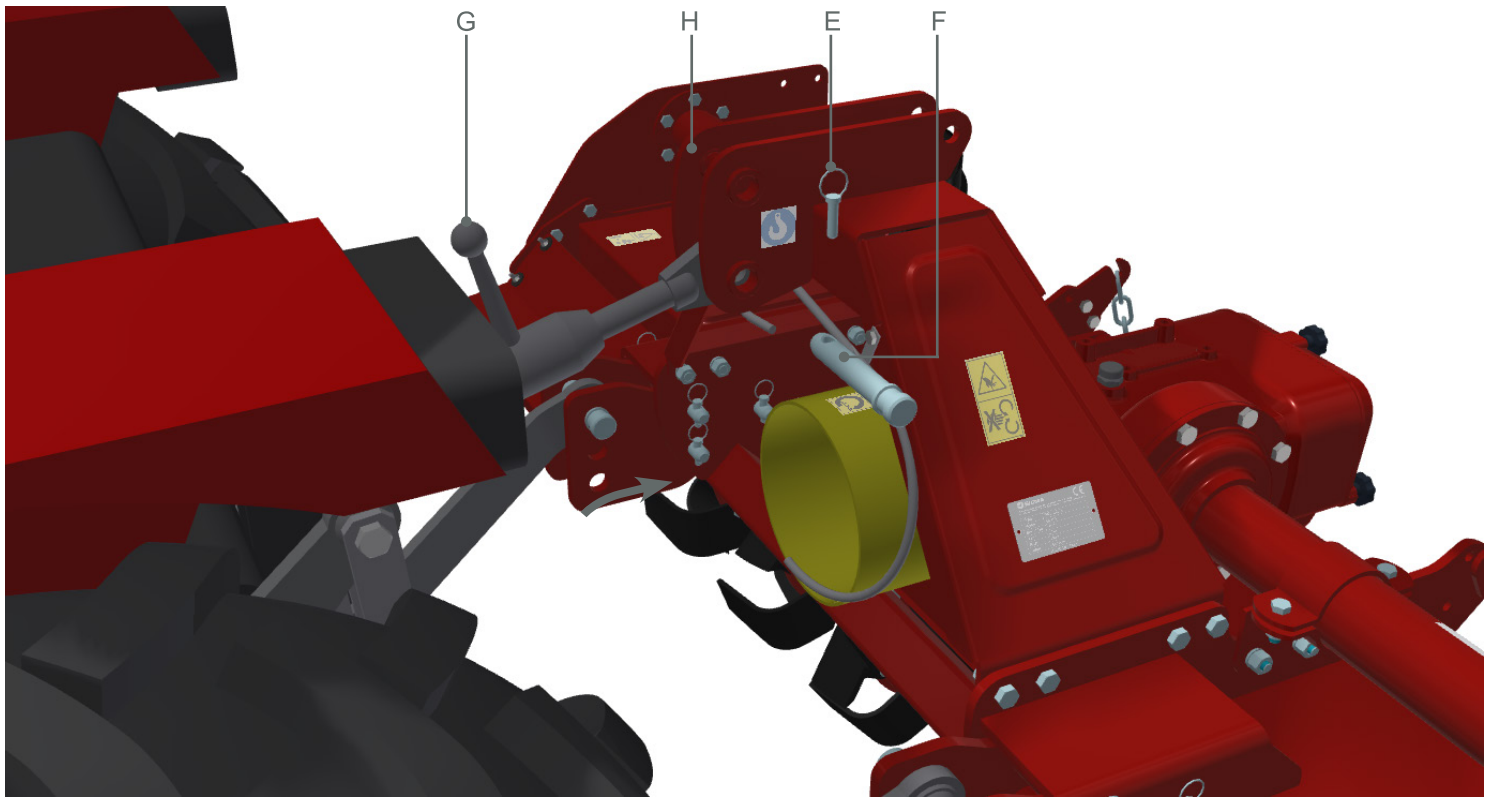

To connect the upper third point, the operator must:

- Remove the split pin "E" of the pin "F" of the upper third point of the tiller;
- Slide pin "F" out;
- Release the tie-rod "G" of the tractor upper third point and insert it into the upper third point "H" of the Tiller;
- Reinsert the pin "F" into the upper third point of the Tiller and of the joint of the tie rod "G" of the tractor;
- Reposition the split pin "E" into the hole of pin "F";

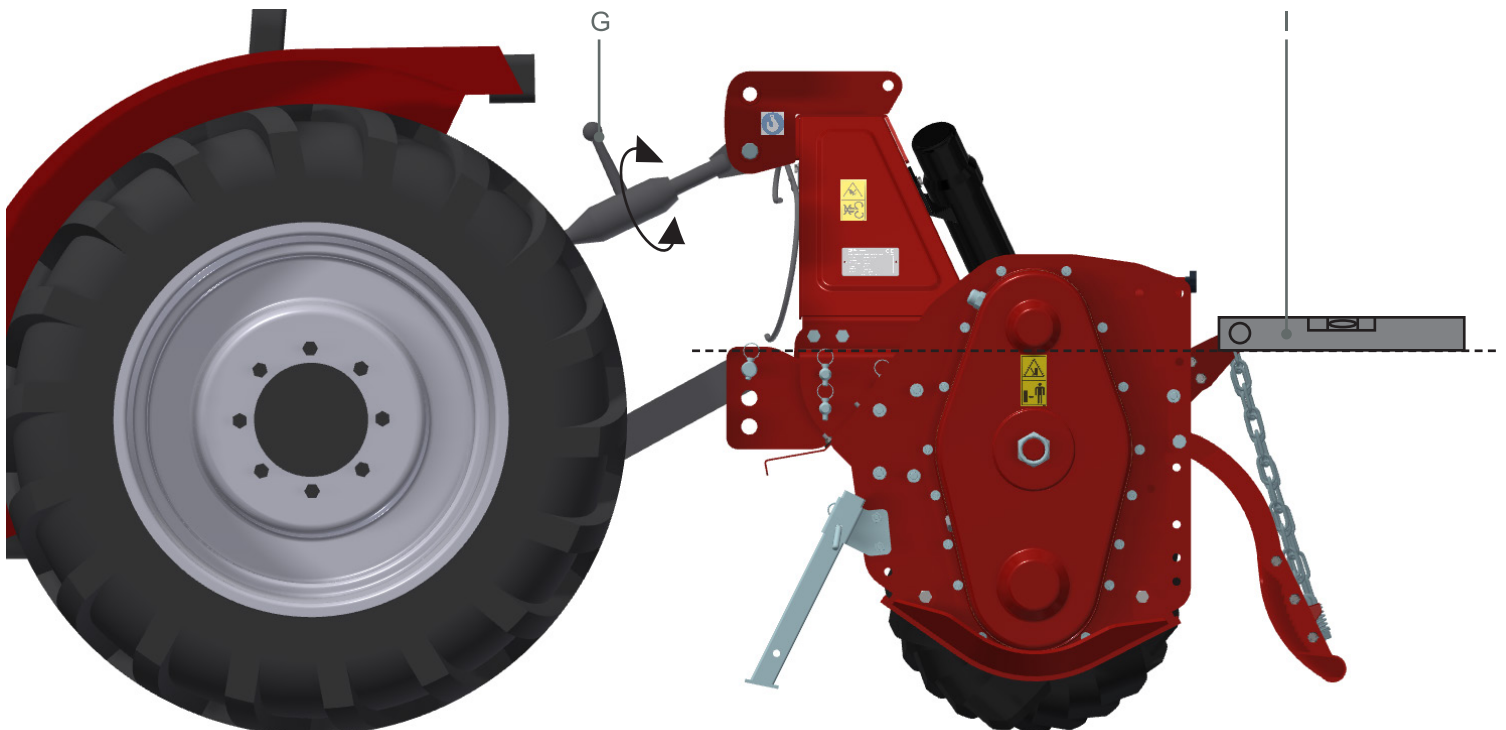

To adjust the tie rod of the third upper point the operator must:

- Position the tractor with the Tiller docked onto a flat, compact and level surface;
- Adjust the length of the tie rod "G" so that the top of the frame of the Tiller is parallel to the ground with the help of a spirit level "I".



## RECOMMENDATION!

To minimise the stresses and to prolong the life of the equipment, make sure that the axis of the PTO of the Tiller and that of the tractor are always parallel during use.

## 5.2 CARDAN SHAFT CONNECTION

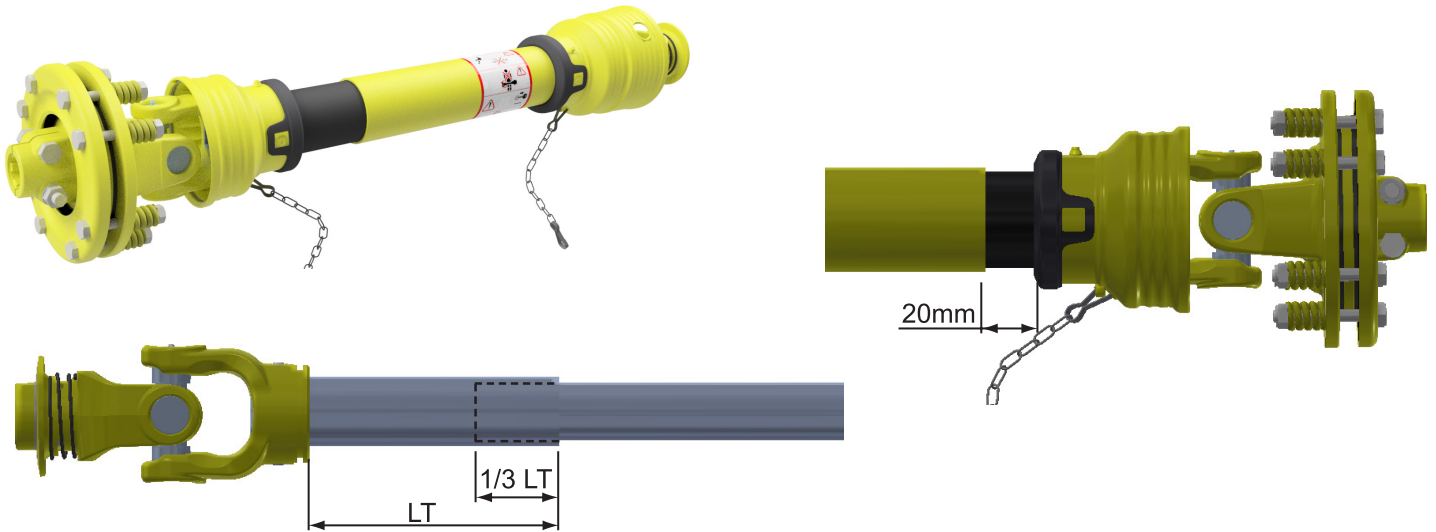

Before assembling the Cardan shaft, the operator must:

- Read and understand the manual of the Cardan shaft and of the tractor
- Check that the Cardan shaft protection is intact, otherwise proceed appropriately by consulting the relevant user manual.
- Check that the number of revs. and the direction of rotation of the tractor PTO correspond to those of the Tiller. If the direction of rotation of the Tiller does not correspond to that of the tractor, contact the dealer or an authorised workshop;
- Verify that the minimum and maximum length of the Cardan shaft are those required by the tiller-tractor coupling. Remember that when at maximum extension, the pipes must overlap at least 1/3 of the length of the internal pipe. Moreover, in the maximum closure position of the pipes, the minimum clearance allowed of the plastic protections must be at least 2 cm. in order to prevent damage to the protections and to the gear transmission. In the case it requires to be cut adequately, cut accordingly; consult the use and maintenance manual of the cardan shaft or turn to an authorized dealer who will know how to proceed.

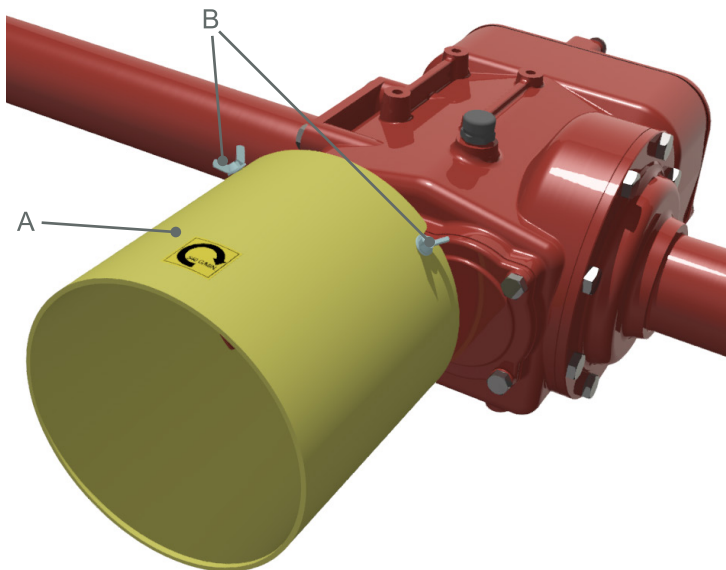

Cardan shaft, the operator must:

- Remove the protection "A" by loosening the thumb screws "B" that secure it to its support.
- Orient the Cardan shaft in the correct direction, as indicated by the symbol stamped on the protection of the shaft. The safety device (clutch) should point towards the Tiller.

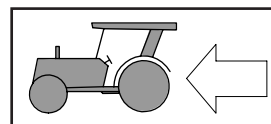

- If necessary, extract the two bolts "C" that lock the clutch and insert its grooved hub into the PTO shaft of the Miller.

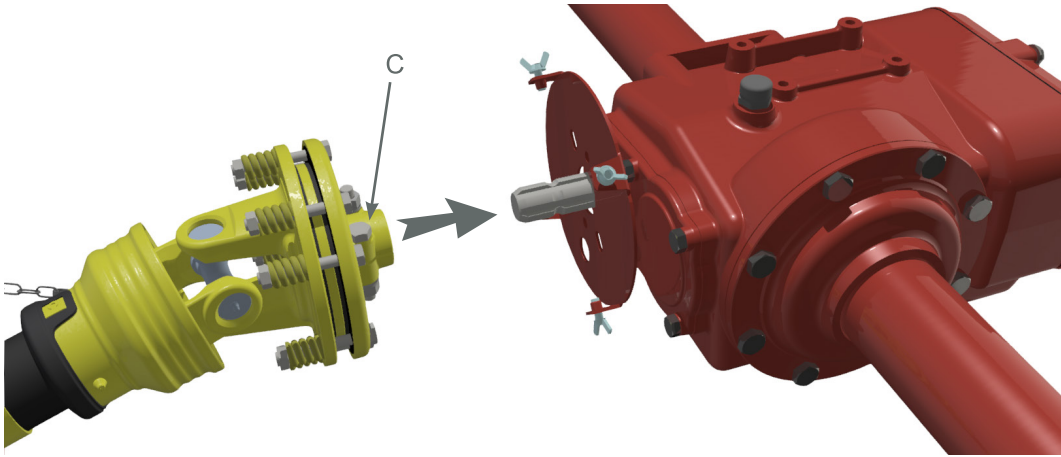

- Reposition the bolts "C" aligning them with the shaft grooving and tighten them.
- Slide the protection of the PTO along the Cardan shaft inserting it from the opposite side and reposition it on its support.
- Tighten the thumb screws.

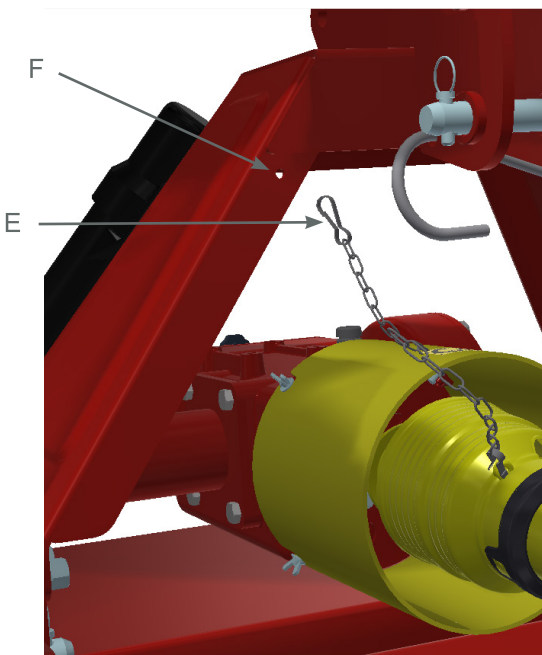
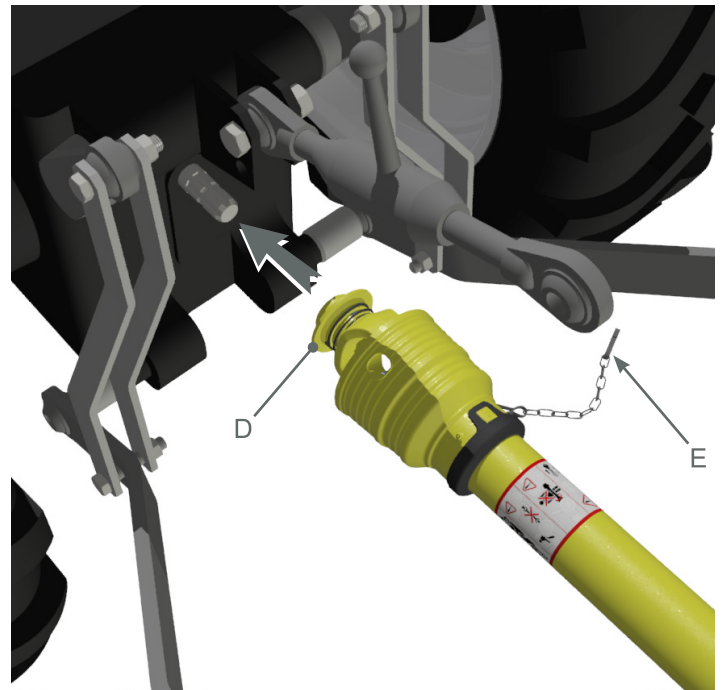
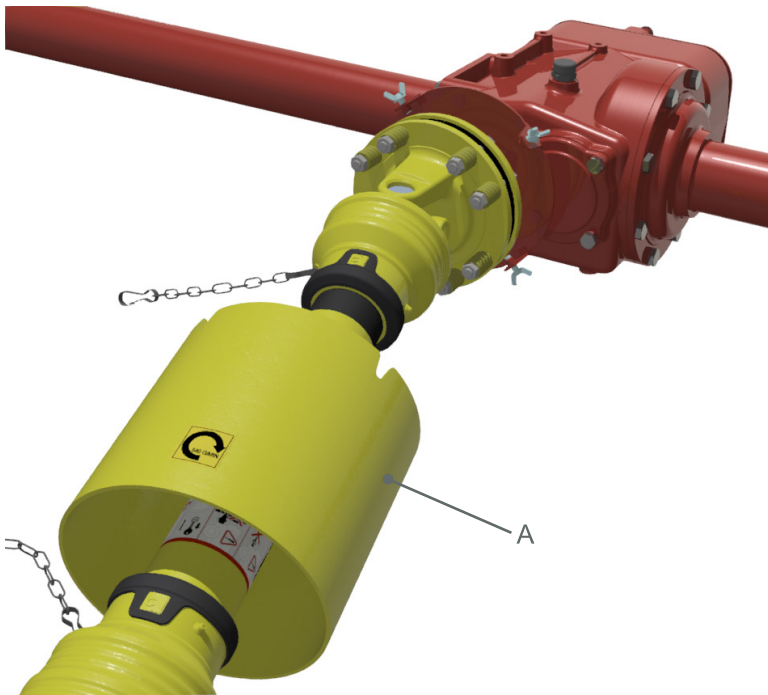

- While holding the PULLCOLLAR safety collar "D" or the pin (depending on the type of Cardan shaft), insert the hub of the Cardan shaft on the PTO of the Tiller until it stops; release the PULLCOLLAR safety collar or pin and retreat with the Cardan shaft until the pin itself connects with an audible "click" in its housing;
- Then connect then carabiners "E" of the retaining chains of the cardan shaft protection to the relevant holes "F" of the Tiller and of the tractor.

### 5.3 CHECK THE STABILITY OF THE TRACTOR-TILLER COMPLEX.

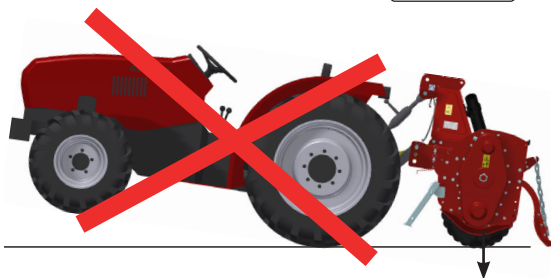

#### CAUTION RISK OF INSTABILITY AND TIPPING!

The weight of the Tiller changes the stability of the tractor-tiller unit, influencing the ability of steering and of braking. As such, proceed at a moderate speed. In particular, it should be noted that the front axle must always be carrying a load of at least 20% of the weight of the tractor-tiller unit.

Check the lifting capacity and stability of the tractor using the following formula and, if necessary, before applying the front weights.

$$M \times (S1+S2) \leq 0.2 T \times i + Z \times (d+i)$$

$$M \leq 0.3T$$

<b>i</b>	= wheelbase
<b>d</b>	= distance between the front axis and the ballasts
<b>S1</b>	= Distance between centre of the rear axle and centre of the lower connection points
<b>S2</b>	= distance between the centre of the lower hitch points and the barycentre of the tiller
<b>T</b>	= weight of the tractor + 75Kg (operator)
<b>Z</b>	= mass of the ballast
<b>M</b>	= the mass of the machine

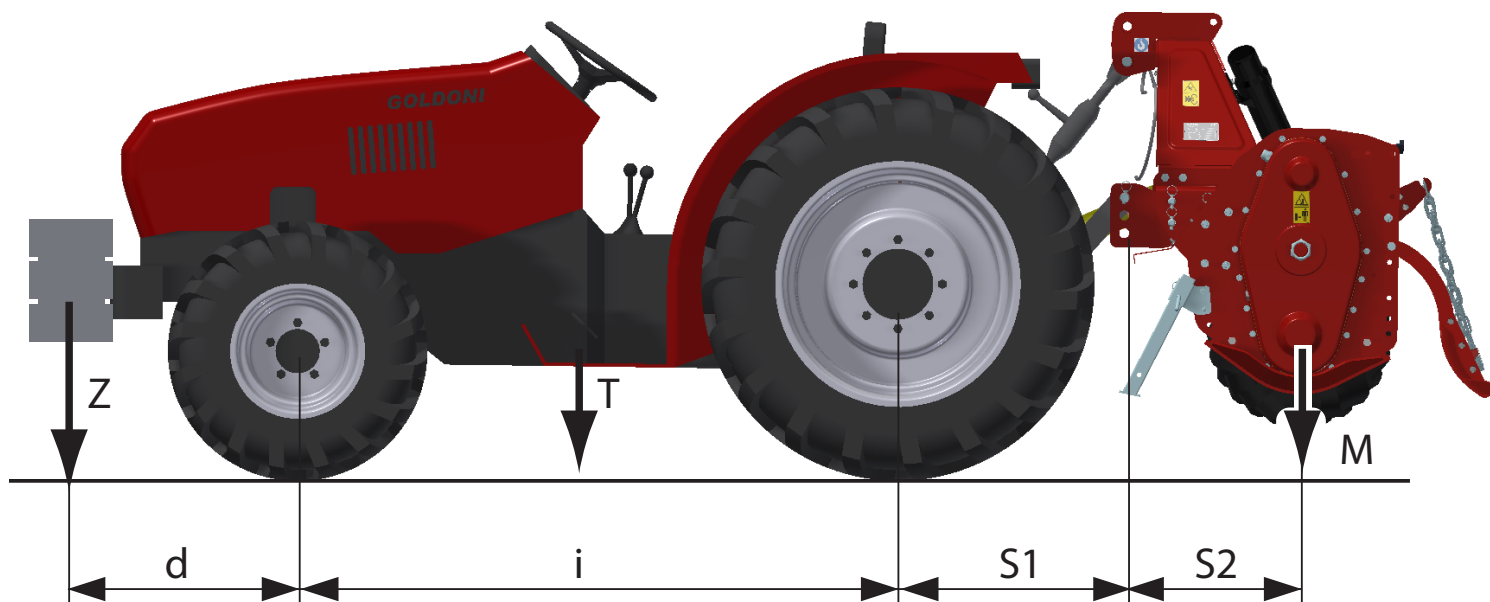

## 5.4 ROAD TRANSPORT

Arts. 61 and 104 of the Highway Code require that the maximum width of vehicles on the road is 2.55 metres so the SPR 160, SPR 185 and SPR 210 can be used on roads as their maximum dimensions are no longer than that stated. The Tillers SPR 235 and SPR 260, whose maximum dimension is respectively 2.66 m and 2.91 m must be considered exceptional agricultural machines. They must therefore be issued with authorisation valid for one year and that is renewable, issued by the relevant A.N.A.S. department for state roads and by the relevant region for the remaining road network" (according to Art. 104 of the Highway Code).

"For exceptional agricultural machines that exceed the width of 3.20 m, the authorisation prescribes technical escort. This escort can be provided with vehicles available to the agricultural company [...]" (according to Art. 104 of the Highway Code). For more information it is advisable to consult the Highway Code.

## 6. ADJUSTMENTS

### 6.1 ROTATION SPEED GEAR (ROTOR)

To modify the rotor rotation speed, the positions of the gears contained in the gear box must be changed.



#### WARNING RISK OF BURNS!

Before working, wait for the gearbox to cool, wear gloves and all the necessary P.P.E. as there is a danger of burns.

To adjust the gearbox the operator must:

- Drain the oil in the boxes of the gear unit as indicated in para. 9.1 storing it in a clean container as, due to the fact that it has not yet been used, it can be reused at a later date;
- Loosen and remove the 3 screws "A";
- Remove the gear cover "B" being careful not to damage the gasket which, in this case, must be replaced (the transmission gears rest against the lid); the gear meshes can now be extracted manually.
- Choose the speed of rotation of the rotor by referring to the table below and determine which gears to use; for example if the PTO of the tractor works at 540 rpm and the rotor should turn at 260 rpm, use the gears with 17 and 23 teeth where the gear with 23 (Z1) teeth is the driving element one and the 17 (Z2) one is the driven one.

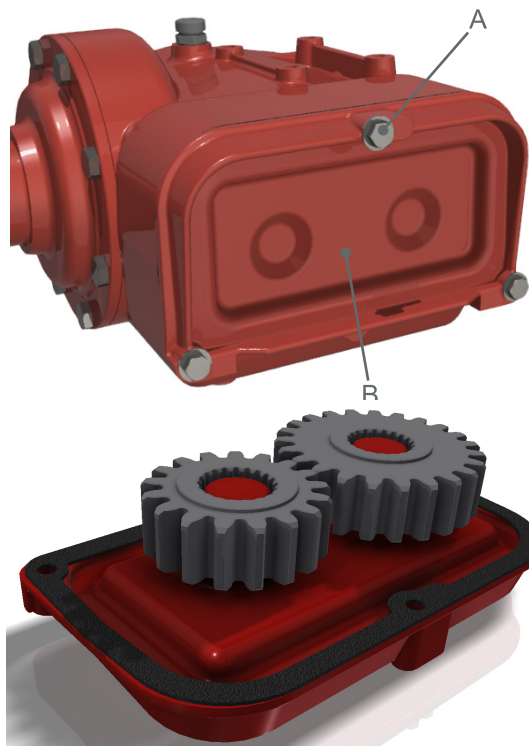

Number of PTO rpm	Z1 Driving gear	Z2 Driven gear	Number of revolutions rotor
540	17	23	145
	19	21	175
	21	19	215
	23	17	260
1000	15	25	215
	17	23	265

- Manually extract the gear meshes and replace them with the ones chosen earlier. The gears in forward movement are repositioned on the gear cover;
- Replace the cover and its gasket on the box and ensure the tightness of the 3 screws "A" complete with washers.
- Fill the group using the oil previously conserved if not yet used as indicated in paragraph 9.1.

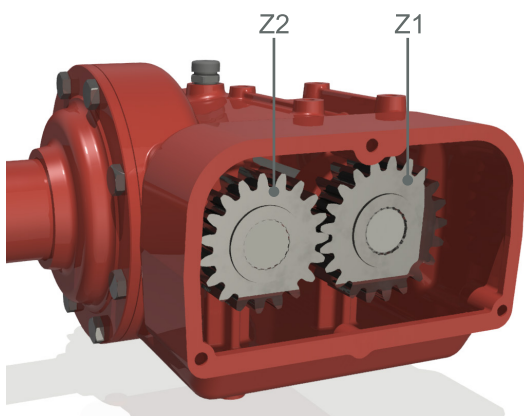

## 6.2 CLUTCH ADJUSTMENT

The Cardan joint and the clutch associated to the machine are dimensioned to transmit suitable power to the Tiller; the calibration value is already set in the factory, therefore it is not recommended to modify it in order to prevent damage to the machine or to the joint itself. SICMA is not liable for damage deriving from incorrect modification of the clutch calibration.

However, adjustment can be made if it is realised that the clutch engages too frequently, even though working on easy land, i.e. neither hard nor compact: this means that the clutch calibration is too low.



### WARNING!

The clutch springs must not be close-wound because the machine would no longer be protected against any overloads.

The clutch associated to the Cardan Shaft is a FD4 EUROCARDAN, with standard calibration of 2200 Nm. To increase the calibration of the clutch, tighten the tightening bolts "C" of the springs by 1/4 of a turn using two 17 mm fork wrenches: there will be an increase in torque capacity of approximately 275 Nm. Loosen the nuts if calibration is to be decreased.

Caution: to prevent malfunctioning of the clutch check that the height of all the compressed springs is the same.

## 6.3 WORK HEIGHT ADJUSTMENT

The work height can be modified by operating on the position of the skids or any rear roller (optional).



CAUTION DANGER OF CRUSHING AND CUTS!

To change the position of the skids, the operator must:

- Raise the Tiller by means of the hydraulic lift of the tractor and lay it on dedicated stands to ensure its stability;
- Stop the engine, remove the tractor keys and keep them in a safe place;
- Keeping them stopped internally with 2 21 mm fork wrenches, first loosen the bolt "D", then bolt "E" and finally bolt "F" to allow sliding of the notched plate "G";
- Raise or lower the skid to the desired height;
- Having reached the desired height, tighten the bolt "F" and all those previously loosened;
- Proceed in the same manner with the opposite skid making sure the height of both is the same, checking that the number of teeth of the adjustment plate "H" that are exposed are the same.

To adjust the work height of the Tillers equipped with rear roller, act on the relevant mechanical or hydraulic adjustment points of the rollers themselves.

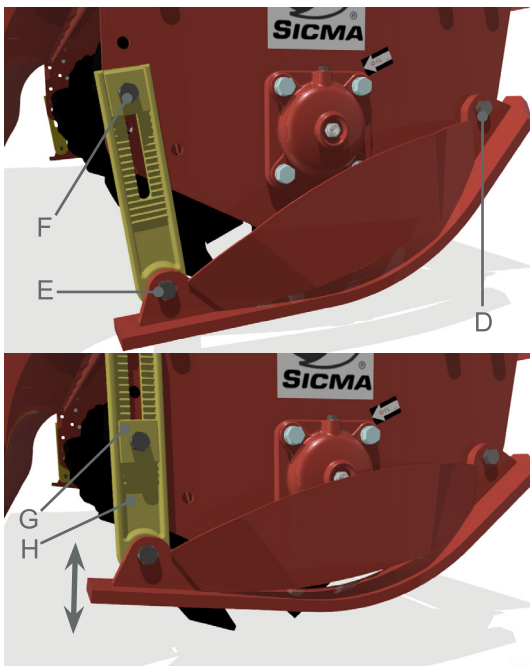
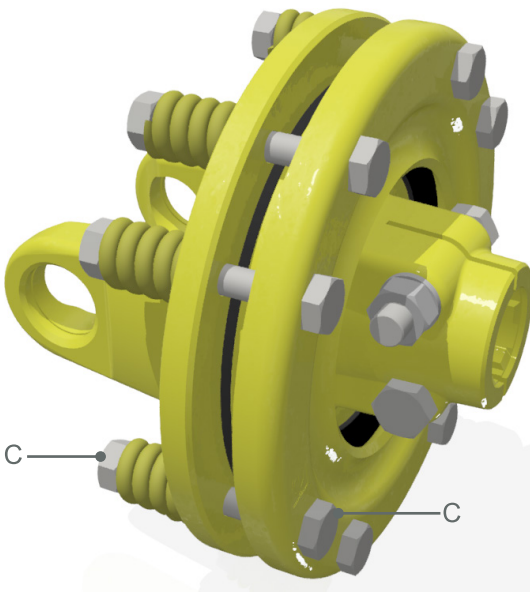

## 6.4 REAR BONNET ADJUSTMENT

If the Tiller has rear cover with chain, the inclination can be adjusted by simply shortening or lengthening the tract of taught chain.

If the Tiller has covers with bonnet presses (optional), the inclination can be adjusted to obtain greater or lesser compacting of the land. The higher the thrust downwards, the better the finish.



### CAUTION DANGER OF CUTS AND SHEARING!

When performing the following operations, it is necessary to wear work gloves ensuring that your hands do not enter between the two covers or between covers and side plates. When adjusting the covers do not lift or lower them by holding them from the sides but only by their lower edge as shown by the arrows in the figure.

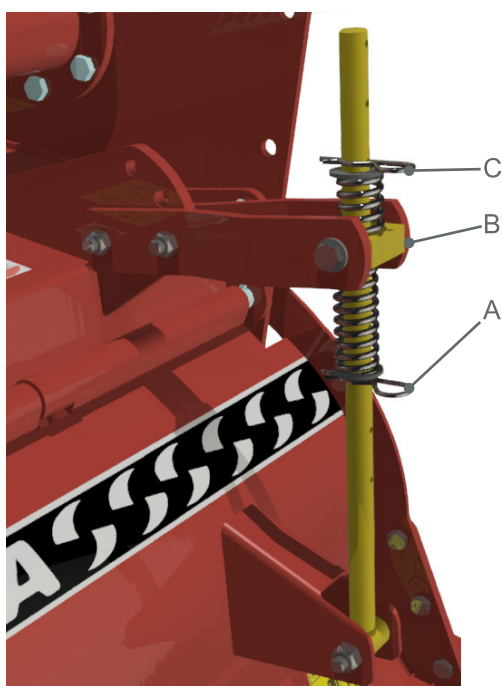
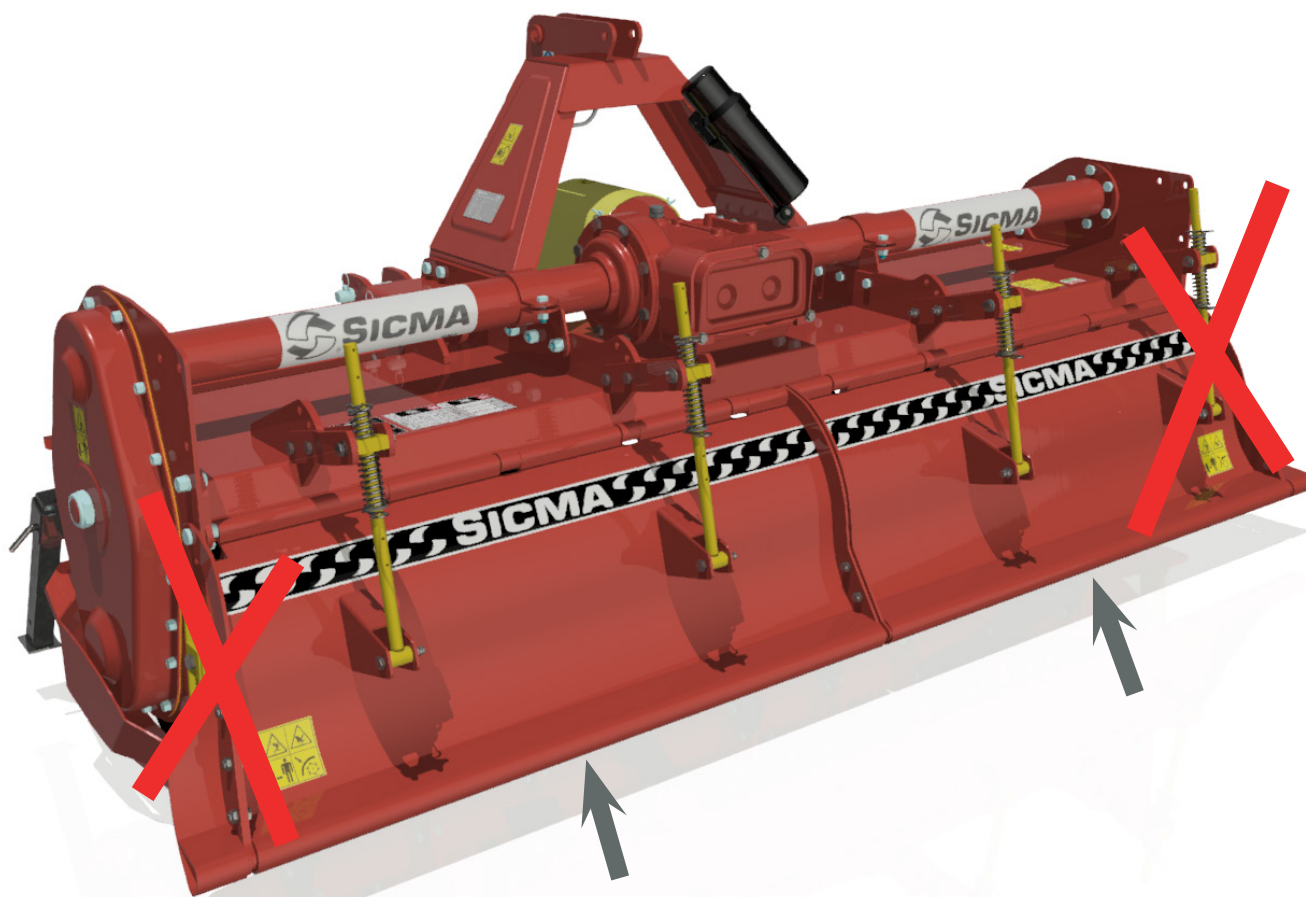

If the cover is to be opened further the operator must:

- Remove the lower split pin "A" of the bonnet press and, without sliding the spring and washer, place it in the lowest hole.
- Repeat the operation for the second rod.
- Lift the cover holding it by its bottom edge. The rods must slide freely within the upper springs and rod support blocks "B" until the latter touches the lower springs.
- Remove the upper pin "C" of one of the rods and reinsert it in the bottom hole. If the operation has been successfully performed, it is now possible to leave the bonnet.
- Perform the operation on the second bonnet press rod.

If there are two covers, perform the same procedure for the other one.

If the cover is to be closed further, proceed in the opposite direction.

## 7. WORKMANSHIP



### NOTE

Prior to working with the equipment read this entire sequence to be prepared in time for any unexpected events.

### 7.1 PREVENTIVE MAINTENANCE

Before using the machine for the first time, or after a lengthy period of inactivity, the operator must:

- Check that the machine is not damaged.
- Check that the mechanical parts are in a good condition and are not rusted.
- Verify that the status of tool wear is not excessive.
- Grease all mobile parts precisely.
- Make sure that there are no leaks from the pipes or fittings.
- Check that all the safety guards are properly positioned.
- Check the tightness of the nuts and bolts and, if necessary, proceed by consulting the table of tightening torques in para. 14.1.
- Check the oil level in the gear box unit, in the lateral drive sump and in the external side rotor support; if it is necessary to restore to the level, fill up (see chap. 9)

Use the following lubricants:

- oil type: **AGIP-ENI BLASIA 150**
- grease type: **AGIP GREASE MU EP 2**

### 7.2 USE

The Tiller has interchangeable equipment (Machinery directive art. 1 para. b) and, to be used, must be connected to a tractor. It is from the tractor itself that all Tiller controls are managed.

The operator must refer to the tractor manual in order to use the tiller correctly.

The tractor and its equipment must be used by one operator only positioned within the tractor cab.

After performing all the checks and suitable adjustments (chapter 6), with the Tiller connected to the tractor (using the three-point hitch), but with the Cardan shaft disconnected, move to the work area. Remember to keep the machine lifted in order to prevent the hoes from touching the ground (at least 20 cm).



### WARNING!

Before starting work, make sure that no persons or animals are within the radius of action of the machine.

Once arrived at work the operator must:

- Engage the parking brake.
- Stop the engine.
- remove the ignition key and keep it.
- Connect the Cardan shaft to the tractor PTO (see para. 5.2).

It is good practice to start the equipment in reduced normal conditions, especially in cold environments, to allow the system to run-in and to prevent Tiller malfunctioning.

Once connected to the Cardan shaft, the operator must:

- Start the tractor engine.
- Disengage the parking brake.
- Start the Machine by activating the PTO of the tractor.
- With the vehicle running at a speed not exceeding 6 km/h, operate the hydraulic lift allowing the Tiller to descend and penetrate the soil.



The tractor forward speed should be reduced to approximately 2 km/h if the land is difficult to work (hard, stony, etc.).

Keep the tractor engine running at a rev speed that assures the machine the power needed for the job it is performing.

Move a short distance with the Tiller activated and check the quality of the work performed; if it is not satisfactory, repeat and revise adjustment of the machine (chap. 6).



#### DANGER OF CUTTING AND SHEARING OF HANDS AND FEET!

Never place hands and feet near to the tools-holder rotor when it is rotating (or when in zero energy state).



#### ATTENTION: DANGER OF OBJECTS BEING THROWN

During operation, the machine can project material from the back: make sure that people and animals are at least 5 metres from it.

In the operations of changing direction, turning and reversing, slightly raise the Tiller from the ground, after switching off the PTO to prevent damage to the structure.

When the work has been finished, the operator must:

- Engage the parking brake.
- Stop the engine.
- Remove the ignition key and store it in a safe place.
- Disconnect the Cardan shaft from the tractor PTO and place it in the relevant support hook.
- Disengage the parking brake and, when necessary, restart the tractor engine.
- Paying attention during movement that there are no exposed persons, animals or objects.

Having reached the depot, the operator must:

- Place the tiller on the ground
- Engage the parking brake.
- switch the engine off
- Remove the ignition key and store it in a safe place.
- Arrange for cleaning of the Tiller (chap. 9).
- Check that there are no oil leaks. If any are found, arrange for repair (risk of soil pollution)
- Check and if necessary, replace any worn parts (chap. 8).



#### NOTE

If during the work the equipment stops, refer to chap. 8 "Stops".

## 8. STOPS



#### ATTENTION INJURY HAZARD!

Only qualified operators that have read and understood the safety requirements (Chap. 2) may perform the operations described below.

Moreover, they must check that there are no persons, animals and objects exposed in the dangerous area.

The equipment must be stopped in the following ways:

- Temporary stop.
- Stop at the end of the day.
- Stop for long periods.
- Emergency stop.

## TEMPORARY STOP

To stop the Tiller temporarily, simply deactivate rotation of the tractor PTO by activating the relevant control in the tractor control panel.

If the operator must get off the tractor, they must:

- Engage the parking brake.
- switch the engine off
- Remove the ignition key and store it in a safe place.
- get off the tractor.

## DAY END STOP

- Engage the parking brake.
- Stop the engine.
- Remove the ignition key and store it in a safe place.
- get off the tractor.
- Arrange for cleaning of the equipment (chap. 9).
- Check that there are no oil leaks. If any are found, arrange for repair (risk of soil pollution)
- Check and if necessary replace any worn parts.

## LONG DOWNTIME PERIODS

- Activate the tractor parking brake.
- Lower the machine resting feet.
- Place the tiller on the ground.
- Turn the tractor engine off.
- Remove the ignition key from the control panel and keep it.
- Descend from the driver position.
- Disconnect the Cardan shaft.
- Rest the Cardan shaft on the relevant hook.
- Pull out the split pin and the gudgeon and detach the tie rod (upper third point).
- Secure the tie rod to the relevant support on the tractor
- Pull out the split pins and the connecting pins and then the tractor's rear hydraulic lift arms from the Tiller's hitch points.
- Climb back onto the tractor.
- Start the tractor and move away carefully.
- Lubricate all parts of the Tiller with an anti-rust product.

The machine must be parked on flat land and within a protected area, so as to prevent unauthorised staff from approaching.

## EMERGENCY STOP

- Stop rotation of the tractor PTO via the relevant control in the tractor control panel.
- Engage the parking brake.
- Turn the tractor engine off.
- Remove the ignition key and store it in a safe place.
- Identify the cause which induced the emergency stop; if necessary, consult section 14.2 "Troubleshooting"

Decide:

- Whether it is necessary to bring the equipment to zero energy state.
- Whether to call for technical assistance.
- Whether it is possible to arrange for repair.

After remedying the cause that prompted the emergency stop it is possible to restart the equipment.



## 9. ORDINARY MAINTENANCE



### ATTENTION DANGER OF INJURY AND DAMAGE

Only qualified operators that have read and understood the safety requirements (Chap. 2) may perform the operations described below. Moreover, they must check that there are no persons, animals and objects exposed in the dangerous area.

The operator must know and scrupulously follow the indications and must have placed the machine out of service.

The periodic controls and the maintenance operations described in this chapter must be performed in the times and ways established and are the operator's responsibility.

Failure to comply with the standards and maintenance times jeopardises efficient functioning of the machine and its duration and as a consequence validity of the warranty.



For any other maintenance, consult para. 14.2 "Troubleshooting" or contact the Manufacturer or its After-sales centres.



Given the complexity of the equipment, repairs, modifications and special maintenance other than those listed below should NOT take place without consulting the Manufacturer or its service centres. These will, as the case may be, give permission to proceed, issuing all the necessary instructions or will recommend the intervention of their own technician.

These precautions are due to the fact that, incorrect or untimely operations can result in anomalous operating conditions, damage to the equipment and risks for staff.



### ATTENTION DANGER OF INJURY AND DAMAGE

Before performing maintenance, read all of this part to be prepared in time and for any problem that may occur.



### ATTENTION OVERTURNUNG, CRUSHING HAZARD

Ensure stability of the equipment before performing any maintenance intervention (the maximum gradient limit of the ground is 3°).

Before carrying out any maintenance operation, the operator must take the tiller to the zero energy state (para. 2.10) 2.10).



The maintenance technician and any assistants must have the relevant Personal Protection Equipment (P.P.E.) available and use them as required.

Do not carry out repairs, the details of which are unknown. Always follow the instructions and in the absence of these, contact the supplier or expert personnel;

Do not use lifting points other than those prescribed.

Make sure that the lifting device chosen is suitable to perform the operations in accordance with the safety regulations.

Do not keep the tractor engine running in closed areas without a suitable ventilation system to dispose of the harmful exhaust gases that concentrate in the air.

Avoid prolonged or repeated skin contact with lubricants because they could create skin disorders or other syndromes.

Do not swallow fuel / lubricants / fluids. In the event of accidental contact the eyes, wash them well with water.

Do not weld in closed or inadequately ventilated areas.

Do not weld on coated surfaces, to prevent the development of toxic vapours. Remove paint with suitable products and then wash the surfaces and let them dry.

Relieve pressure from circuits before working on the hydraulic system;





#### ATTENTION OIL EJECTION!

Do not use hands to identify leakage of fluids under pressure; fluid leaks under pressure can penetrate the skin and eyes, with very serious consequences.

### 9.1 CONTROL AND REPLACEMENT OF THE OIL IN THE GEARBOX UNIT



#### ATTENTION BURNS HAZARD!

Wait for the gearbox to have cooled down before touching it.



#### ATTENTION POLLUTION OF THE LAND AND WATER TABLE HAZARD!

The operator must pay attention to oil leaks and perform relative maintenance immediately. Moreover, oil must not be poured onto the ground when topping-up or replacing the oil.



#### WARNING!

Recover used oils and dispose of them properly in appropriate collection centres as, according to the current laws, they must not be released into the environment as they have been classified as hazardous waste. It is therefore necessary to turn to the "Waste Oil Mandatory Consortium" ([www.coou.it](http://www.coou.it), Green Number 800-863048). For the other countries, refer to the relative anti-pollution regulations in force.



The oil level control in the gear unit box must be performed verifying the mark left by the oil itself on the load cap dip-stick A, which must be between the two reference signs (minimum and maximum). The control must be performed every 50 working hours.

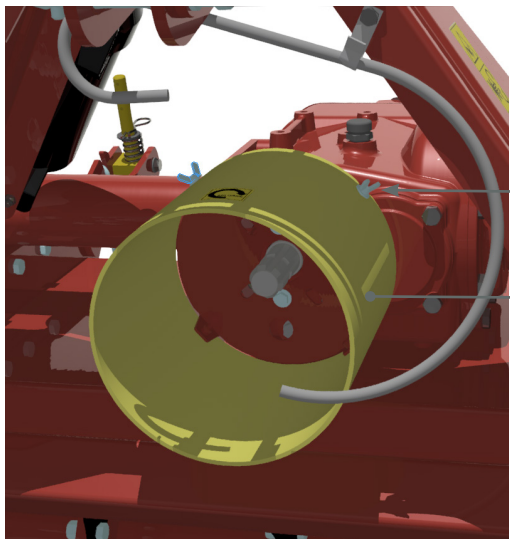

If it is necessary, in order to carry out oil filling, the operator must:

- Unscrew and remove the oil load cap "A".
- Top up oil type AGIP-ENI BLASIA 150 up to the relevant level using a funnel.
- Refit the filler plug and tighten it.

The oil on the gearbox unit must be replaced as follows:

- the first time after the first 50 hours of work
- Every 500 hours of work.

To perform an oil change it is necessary to reach the drain plug behind the Cardan protection. Therefore the operator must:

- Remove the shaft protection "B" by loosening the 4 fin screws "C".
- Loosen and extract the bolts "D".
- Then remove the support "E".
- Place a container under the oil drain "F" and remove the oil filler cap "A" to enable correct flow out of the used oil.
- Unscrew and remove the cap "F" and wait until the oil flows out completely of the gearbox.
- Replace the cap "F", tightening it carefully.
- Dispose of the used oil in appropriate containers for used oils
- Using a funnel, fill up with oil type AGIP-ENI BLASIA 150 (approximately 6 litres) until reaching the correct level shown on dipstick.
- Replace the dipstick "A" and tighten.
- Replace the support "E" and the Cardan protection "B".



## 9.2 CONTROL AND REPLACEMENT OF THE OIL IN THE LATERAL DRIVE SUMP

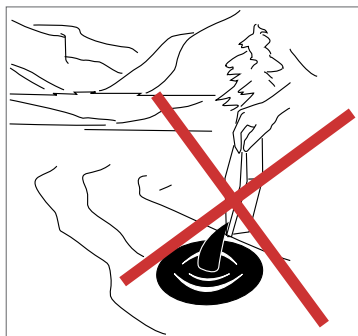

### WARNING!

Recover used oils and dispose of them properly in appropriate collection centres as, according to the current laws, they must not be released into the environment as they have been classified as hazardous waste. It is therefore necessary to turn to the "Waste Oil Mandatory Consortium" ([www.coou.it](http://www.coou.it), Green Number 800-863048). For the other countries, refer to the relative anti-pollution regulations in force.



### ATTENTION POLLUTION OF THE LAND AND WATER TABLE HAZARD!

The operator must pay attention to oil leaks and perform relative maintenance immediately. Moreover, oil must not be poured onto the ground when topping-up or replacing the oil.

The oil level in the lateral drive sump must be controlled every 50 working hours, verifying that it is visible inside the lateral inspection window "G".

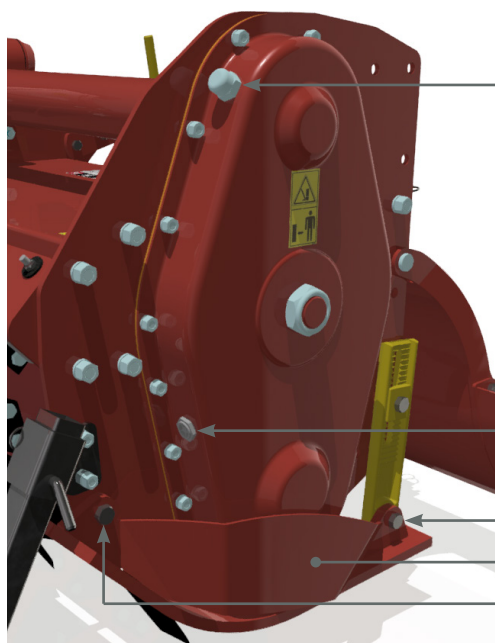

H If it is necessary to top up, the operator must:

- Remove the filler cap "H"..
- Using a funnel, fill up with oil type AGIP-ENI BLASIA 150 until it is visible from the window "G".
- Re-position and tighten the level cap "H";

The oil in the lateral drive sump must be replaced every 500 work hours.

To change the oil, the operator must:

- Remove the side rail "I" by removing the bolts "M".
- Remove the filler cap "H"..
- Place a container below the sump at the drain plug "N" and remove the latter to allow the oil to drain out completely.
- Replace and correctly tighten the drain plug "N".
- Top-up with oil type AGIP-ENI BLASIA 150 until it is visible from the inspection window "G".
- Re-position and tighten the level cap "H";
- Reassemble the lateral slide "I" making sure that the height is the same as that of the skid opposite.
- Dispose of the old oil as described above.



### 9.3 CONTROL AND REPLACEMENT OF THE OIL IN THE EXTERNAL ROTOR LATERAL SUPPORT

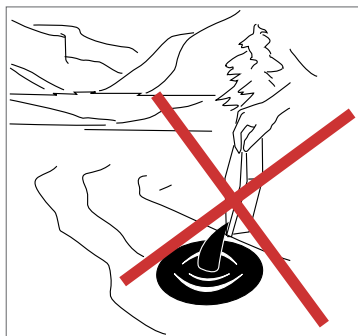

#### WARNING!

Recover used oils and dispose of them properly in appropriate collection centres as, according to the current laws, they must not be released into the environment as they have been classified as hazardous waste. It is therefore necessary to turn to the "Waste Oil Mandatory Consortium" ([www.coou.it](http://www.coou.it), Green Number 800-863048). For the other countries, refer to the relative anti-pollution regulations in force.



#### ATTENTION POLLUTION OF THE LAND AND WATER TABLE HAZARD!

The oil level in the rotor lateral support must be controlled every 50 working hours, verifying that the oil present is visible inside the inspection window "O" situated on the support itself.

If it is necessary to top up, the operator must:

- Remove the cap "P".
- Top-up with oil type AGIP-ENI BLASIA 150 until it is clearly visible from the inspection window "O".
- Replace and correctly tighten the plug "P".

The oil rotor lateral support must be replaced as follows:

- the first time after the first 50 hours of work
- Every 500 hours of work.

To replace the oil the operator must:

- Remove the side rail "Q" by unscrewing the bolts "R".
- Place a container below the support.
- Loosen the four bolts "S" that secure the support and allow the oil to drain out completely.
- Screw the four bolts "S" previously removed.
- Top-up with oil type AGIP-ENI BLASIA 150 until it is visible from the inspection window "O".
- Replace and correctly tighten the plug "P".
- Replace the side rail "Q" by tightening the bolts "R".



### 9.4 REPLACEMENT OF TOOLS HOES/BLADES

Every 50 hours of work, visually check the wear of the hoes/blades/teeth.

Replacement of tools must be carried out when, due to their wear and tear, the quality of the soil work is compromised.

Wear depends on the number of hours worked and the type of soil being worked.

Replacement of the hoes or blades must be performed when their thickness is reduced excessively while replacement of the teeth should take place when their length is reduced or when they begin to demonstrate an excessively rounded form.



#### WARNING!

Do not mount non-original tools as this could result in abnormal vibrations of the machine.



#### ATTENTION CRUSHING HAZARD!

Ensure the stability of the equipment before attempting any maintenance.

During replacement of the tools with the Tiller raised off the ground, do not rely on the hold of the hydraulic lifter of the tractor: insert mechanical struts or support trestles between the machine and the ground to prevent unwanted and dangerous descents of the machine.



To perform the following operations, the operator must wear gloves and glasses and must NEVER be positioned UNDER the rotor.

If the Tiller is equipped with **hoes/blades**, for their replacement, the operator must:

- Hitch the tiller to the tractor without Cardan shaft.
- Lift the Machine using the hydraulic lift of the tractor by a maximum of 10 cm from the ground.
- Strut the tiller with supports of suitable size
- Locate the worn hoes/blades and, starting with one of these, unscrew the bolts "A" that anchor it to the flange.
- Reposition the new tool in the exact original position and tighten the bolts "A" respecting the torque values indicated in the table in paragraph 14.1.
- Proceed in the same way for the other worn hoes/blades.

If the Tiller has **teeth**, for their replacement, the operator must:

- Hitch the tiller to the tractor without Cardan shaft.
- Lift the Machine using the hydraulic lift of the tractor by a maximum of 10 cm from the ground.
- Strut the tiller with supports of suitable size
- Locate the worn teeth and, starting with one of these, unscrew the bolts "A" that anchor it to its support.
- Reposition the new tool in the exact original position and tighten the bolt "A" respecting the torque values indicated in the table in paragraph 14.1.
- Follow the same procedure for the other worn teeth.

The request for replacement tools should be made to the SICMA dealer tools and must be accompanied by code, description and quantity (see table below).

Tool type	SPR tiller width					Code
	160	185	210	235	260	
	Quantity					
Curved hoes kit	18	21	24	27	30	4824501
HITITE curved hoes kit	18	21	24	27	30	4824006
Square hoes kit	18	21	24	27	30	4824502
Blade kit	18	21	24	27	30	4824003
Teeth	-	-	39	44	49	4844006

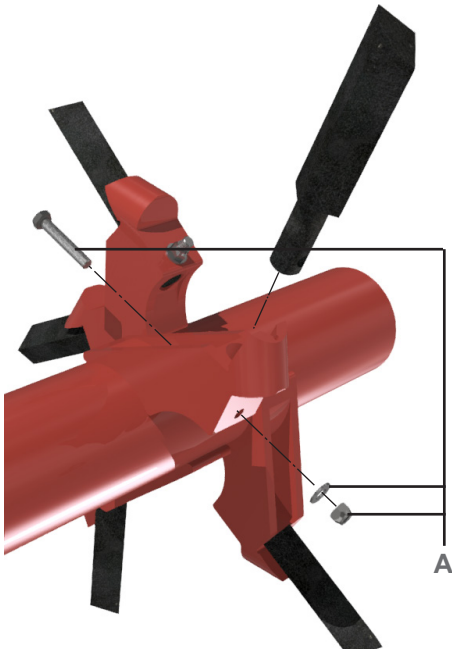
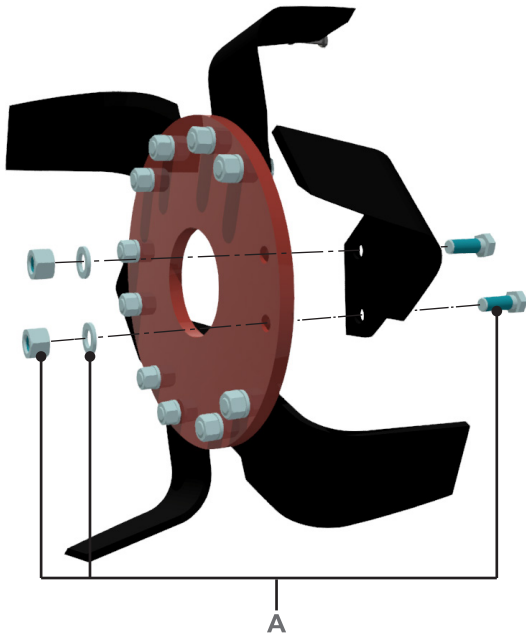



## 10. CARDAN SHAFT

For lubrication and for maintenance interventions, behave as described in the use and maintenance manual by the manufacturer of the Cardan shaft installed.

## 11. CLEANING

Only qualified operators that have read and understood the safety requirements (Chap. 2) may perform the operations described below. Moreover, these must check that there are no persons, animals and objects exposed in the dangerous area.

### ATTENTION CUTTING HAZARD!

Cleaning of the Tiller must be performed wearing gloves and safety shoes and carefully avoiding touching the tools.

The maintenance technician must operate on flat supportive surfaces with the Tiller in the zero energy state (section 2.10).

If compressed air is being used, appropriate glasses are needed.

At the end of each task, carefully wash the entire equipment using an appropriate pressure cleaner, especially the following parts:

- Chassis surface;
- Rotor;
- Hoes/blades/teeth;
- Mast;
- Cover.

For a convenient cleaning of the rotor compartment access via the rear with rear bonnets raised whenever possible; Otherwise access from the front of the tiller.

After washing dry the equipment with compressed air and to prolong its life and reliability, protect the unpainted metal parts with a lubricant oil brush.

## 12. STORAGE AND WINTERING

If the machine is stopped for lengthy periods, it must be stored in a place protected from the elements to prevent damage.

Before storing the machine, it is advisable to clean it thoroughly and to lubricate all the mechanical components to protect them from possible rust (chap. 11).

Before storing the machine **for lengthy periods**, it is recommended to perform the following steps:

- Clean carefully the machine (see chap. 11);
- Carry out a general inspection of the machine to identify any structural damage. If any is found, arrange for repair;
- Identify the presence of deep abrasions of the paintwork and retouch them with special paint;
- Verify that the original safety pictograms are in their positions, that they are intact and legible and if necessary replace them;
- Lubricate all the mechanical components subject to quick disassembly such as the 3-point hitch pins;
- Store the machine in a covered area and on a flat and firm surface if possible.



### ADVICE!

If the machine has disk safety devices (clutch), after having made a note of the height of the compressed springs, it is recommended to loosen the bolts crews that compress the springs in order to prevent the discs blocking each other (seizure).



### 13. SCRAPPING

In the event of scrapping, the machine must be disposed of in suitable waste disposal sites, in compliance with the law in force.

In Italy, prior to scrapping, it is necessary to separate the parts of plastic or rubber from the metal ones.

Collect any waste oil and dispose of it at the appropriate collection centres. The waste oil must be collected appropriately and must not be dispersed into the environment because, according to the legal Standards in force, it is classified as dangerous waste and as such must be brought to the appropriate collection centres. Refer to the "Used Oils Obligatory Oils Obligatory Consortium" ([www.coou.it](http://www.coou.it), free-phone number 800-863048).

Parts consisting solely of plastic, aluminium and steel may be recycled if collected by the appropriate centres.

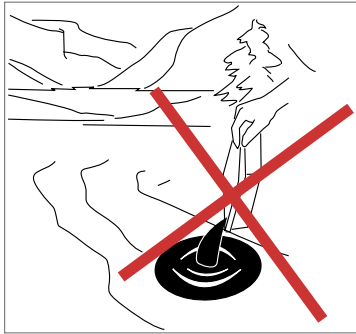

### 14. QUICK CONSULTATION TABLES

The following pages, state the conditions and hypothesis of intervention for each of the cases stated above, in table form.

#### 14.1 TABLE OF TIGHTENING TORQUES

Check the efficiency of all screws and bolts every day. If necessary, replace them immediately, requesting them from the manufacturer, and reposition them (screws, washer, nut) in the same sequence as they were removed.

COUPLING TORQUE				
	Bolt class			
Threading	8.8		10.9	
	Nm	Lb-ft	Nm	Lb-ft
M6	11	8.5	17	12
M8	28	20	40	30
M10	55	40	80	60
M12	95	70	140	105
M14	150	110	225	165
M16	240	175	305	225
M18	330	250	475	350





## 14.2 TROUBLESHOOTING

### NOTE

Before performing the suggested remedies check whether the anomaly persists through a further attempt at use. In the event of intervention, start with the most elementary solutions. If the anomaly persists in spite of the solutions, contact the manufacturer's after-sales centres.

MALFUNCTION	CAUSE	SOLUTION
Oil leak from the gear box or lateral drive sump	<ul style="list-style-type: none"> <li>• Too much oil in the box or lateral sump</li> <li>• Breather plug with faulty valve</li> <li>• Caps loading / unloading /slow levels</li> <li>• Damaged gaskets</li> </ul>	<ul style="list-style-type: none"> <li>• Restore the proper oil level</li> <li>• Replace the breathing cap</li> <li>• Tighten the caps of loading / unloading / level</li> <li>• Replace the gaskets</li> </ul>
Tilling not uniform	<ul style="list-style-type: none"> <li>• Tools worn or damaged</li> <li>• Machine not well adjusted (unaligned skids or rollers)</li> <li>• Machine clogged</li> </ul>	<ul style="list-style-type: none"> <li>• Replace the tools</li> <li>• Carry out adjustments</li> <li>• Decrease advancement speed</li> <li>• Clean the tilling chamber</li> </ul>
Overheating of the conical couple unit	<ul style="list-style-type: none"> <li>• Insufficient oil</li> <li>• Land difficult to work</li> </ul>	<ul style="list-style-type: none"> <li>• Restore oil level</li> <li>• Reduce advancement speed</li> </ul>
Premature tool wear	<ul style="list-style-type: none"> <li>• Sandy or muddy ground</li> </ul>	<ul style="list-style-type: none"> <li>• Reduce advancement speed</li> </ul>
Tools breakage	<ul style="list-style-type: none"> <li>• Stony ground</li> </ul>	<ul style="list-style-type: none"> <li>• Reduce advancement speed</li> </ul>
Machine noise or vibrations	<ul style="list-style-type: none"> <li>• Very hard ground</li> <li>• Rotor unbalanced or damaged</li> <li>• Tools damaged, worn or missing</li> <li>• Worn bearings</li> <li>• PTO not correctly positioned with respect to the tractor PTO</li> <li>• The Tiller works too tilted forward or in reverse</li> </ul>	<ul style="list-style-type: none"> <li>• Reduce advancement speed</li> <li>• Check/replace the rotor</li> <li>• Check/replace the tools</li> <li>• Replace the bearings.</li> <li>• Adjust the Cardan shaft correctly</li> <li>• Adjust the upper third point so that the Tiller surface is parallel to the ground.</li> </ul>
Excessive power absorption	<ul style="list-style-type: none"> <li>• Volume of land worked too high</li> <li>• Excessive work depth</li> <li>• Excessive rotor rotation speed</li> <li>• Tilling chamber clogging (humid land)</li> </ul>	<ul style="list-style-type: none"> <li>• Decrease working depth by adjusting skid heights</li> <li>• Reduce gear speed</li> <li>• Lift the rear cover to facilitate the escape of earth</li> </ul>
Little pulverization of the land	<ul style="list-style-type: none"> <li>• Rear cover too open</li> <li>• Excessive advancement speed</li> <li>• Rotor rotation speed too slow</li> </ul>	<ul style="list-style-type: none"> <li>• Lower rear cover</li> <li>• Reduce advancement speed</li> <li>• Increase gear speed</li> </ul>
Anomalous bounces of the tiller on the ground	<ul style="list-style-type: none"> <li>• Hoes positioning not helical</li> <li>• Hoes inverted, worn or broken</li> <li>• Rotor deformed or with foreign bodies between the hoes</li> <li>• Ground too hard</li> </ul>	<ul style="list-style-type: none"> <li>• Restore the correct helical positioning of the hoes</li> <li>• Replace the hoes</li> <li>• Replace the rotor</li> <li>• Pass several times</li> </ul>



### 14.3 LUBRICATION INTERVALS

	INTERVAL IN HOURS	DESCRIPTION OF THE INTERVENTION
<b>A</b>	After the first 50 hours of work	<ul style="list-style-type: none"> <li>Replace the oil in the gear unit box</li> </ul>
<b>B</b>	Every 50 hours of work	<ul style="list-style-type: none"> <li>Check the oil level in the gear box unit and top-up to the correct level if necessary</li> <li>Check the oil level in the lateral drive sump and top-up if necessary</li> <li>Check the oil level in the lateral support of the external rotor and top-up if necessary</li> <li>Grease the rear roller height adjustment lever</li> </ul>
<b>C</b>	Every 500 hours of work	<ul style="list-style-type: none"> <li>Replace the oil in the gear unit box</li> <li>Replace the oil in the lateral drive sump</li> <li>Replace the oil in the lateral support of the external rotor</li> </ul>

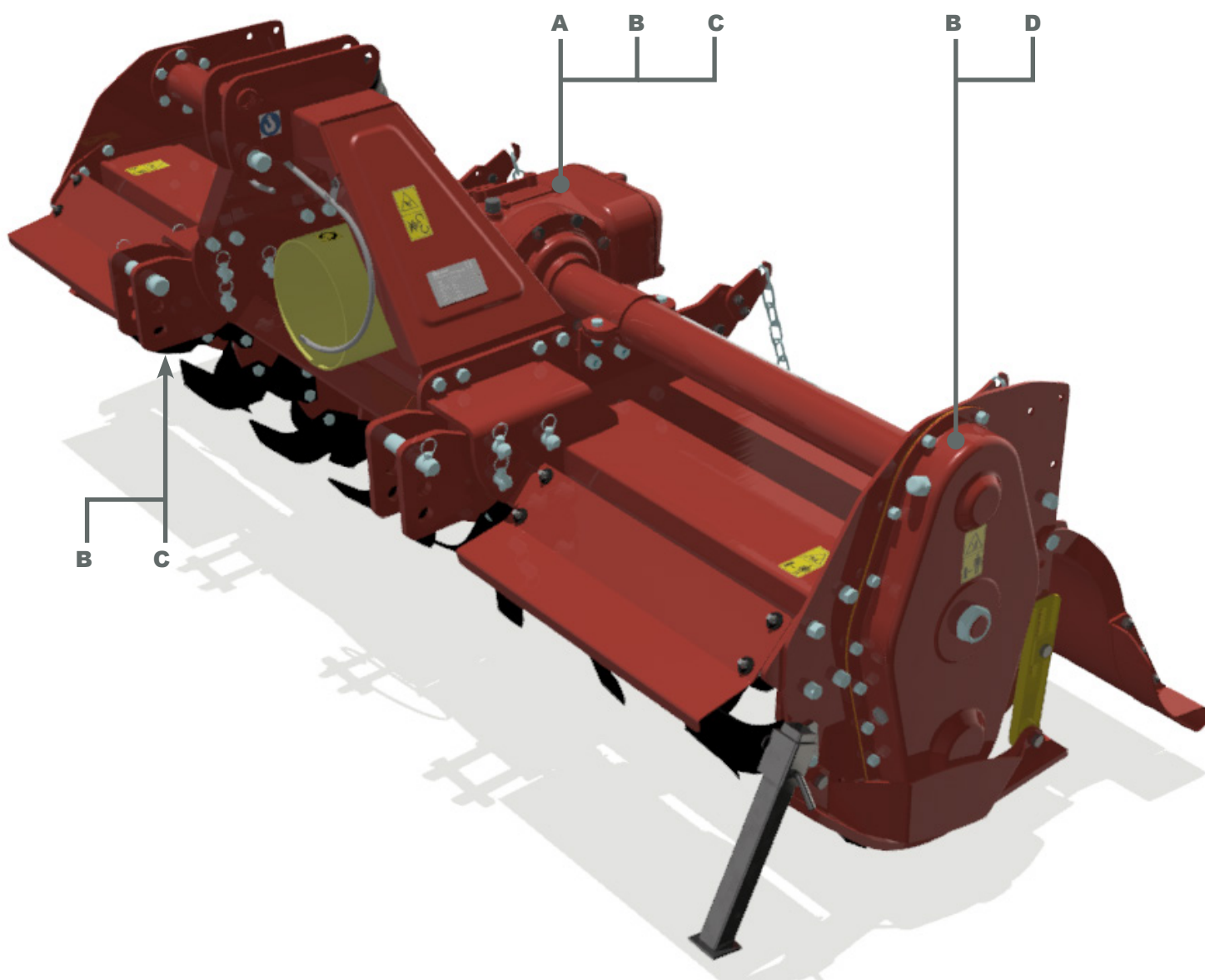

RECOMMENDED LUBRICANTS	
Oil	AGIP-ENI BLASIA 150
Grease	AGIP GREASE MU EP 2

## 15. SPARE PARTS

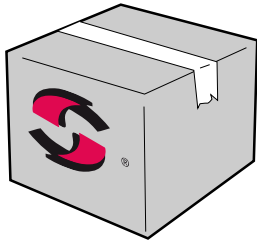

Repairs and replacements must be performed using original spare parts, which must be requested from the Dealer. Remember that the request for spare parts must be correct and accompanied by the following indications:

- Machine Type;
- Serial number;
- The code and description of the spare part requested can be obtained from the Spare Parts Exploded Diagram;
- Requested quantity.

Given the particular stress to which the equipment is subjected and for safety reasons, if pieces are replaced, only use original spare parts.

## 16. WARRANTY

In order to make use of the contractual warranty supplied by the Manufacturer, the operator must scrupulously comply with the precautions indicated in the Use and Maintenance Manual and in particular:

- Must comply with the limits for use provided by the Manufacturer;
- Must not make any changes or modifications to the machine without the written approval of the Manufacturer;
- Must always perform all the maintenance required;
- Must only use original spare parts;
- Must ensure that the personnel engaged in the use of the vehicle meet the necessary requirements in terms of skills and training

The warranty shall not apply if the above conditions are not complied with, even if only partially.

The use of spare parts not approved by the manufacturer will void any warranty and exempts the Manufacturer or the Retailer from liability for malfunctions or accidents.

The removal or the modification of guards and protections relieves the Manufacturer from all liability due to damage/injury caused to objects and/or persons.









SICMA S.p.A.  
Contrada Cerreto, 39  
66010 MIGLIANICO (CH) - ITALY  
Tel. +39 087195841 - fax +39 0871950295